

LINEE
RESIDENZIALI

RESIDENTIAL
SERIES





THE ITALIAN EVOLUTION OF ELECTRICITY

Il valore dei prodotti made in Italy

Progettare e produrre in Italia è la nostra mossa vincente; investire nell'ampliamento dei nostri siti produttivi è la conferma di **una scelta di qualità** che il mercato internazionale ci riconosce. Da oltre 50 anni **arricchiamo la nostra gamma** per consentire la realizzazione di impianti in ambiti civile e industriale, utilizzando prodotti sicuri, che facilitano il lavoro dell'installatore e garantiscono durata nel tempo.

The value of "made in Italy" products

*Designing and manufacturing in Italy is our strenght; the expansion of our manufacturing sites confirms that **our aim is quality** for which we are known in the International markets. Since 1970 **we have enlarged our catalogue ranges** in order to offer a complete solutions for domestic and industrial applications, meeting all safety requirements, reduce installation timings with long lasting products.*

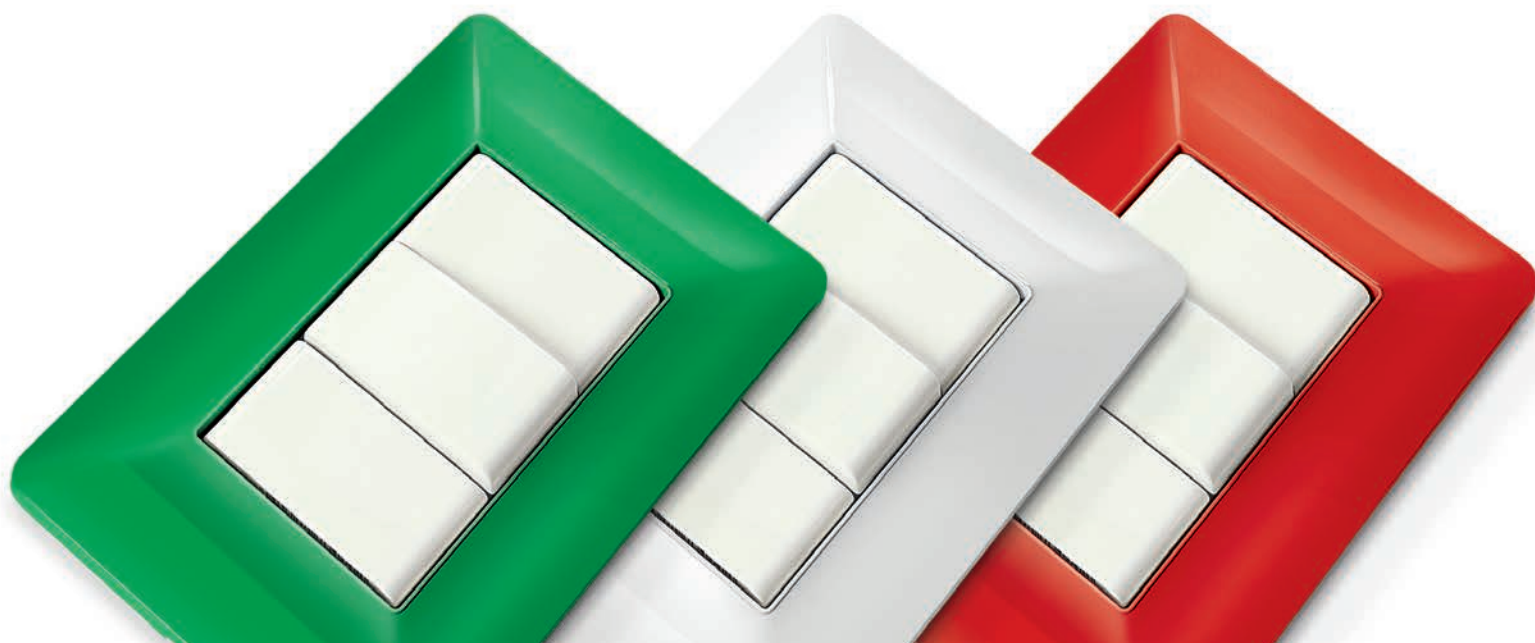



L'orgoglio di una produzione italiana, presente in tutti i continenti

Oggi oltre 80 paesi nel mondo utilizzano il nostro "made in Italy" perché **garantiamo affidabilità e completezza di gamma.**

Più di 5.000 referenze per installazioni in bassa tensione, realizzate nelle unità produttive presenti sul nostro territorio, semplici e veloci da installare, sicure e affidabili per il cliente finale.

Pride of an Italian production, present on all Continents

*Today over 80 countries around the world use ours "made in Italy" because we **guarantee reliability and range completeness.***

More than 5,000 references for low-floor voltage installations, made in production units present on our country, simple and quick to install, safe and reliable for our final customer.



Dalla scelta della materia prima al prodotto finale

Nel corso degli anni si è continuamente implementato un **accurato processo di produzione**, che inizia nel reparto Ricerca e Sviluppo con progetti originali e passa rigorosamente attraverso una meticolosa fase di ingegnerizzazione.

Il supporto del laboratorio interno contribuisce alla verifica delle performance dei prodotti e al mantenimento delle stesse nel tempo: possiamo così garantire **prodotti che incontrano il favore anche dei clienti più esigenti**.

From raw material's choice to final product

*During years, a **careful production process** has continuously improved. It begins in Research and Development department with original projects and strictly goes through a meticulous stage of engineering.*

*Our internal laboratory contributes to check performance's product and to maintain them over time: in this way we could realise **products that satisfy the most demanding customers too**.*



Certificazioni sempre aggiornate

Certifications always updated

Manteniamo alto il livello della nostra qualità: in relazione ad ogni normativa di riferimento vantiamo gli opportuni certificati grazie al **monitoraggio costante sui materiali e sulla produzione**. Il nostro laboratorio effettua tutti i test necessari per garantire il rispetto di ogni normativa. Nel 1998 abbiamo ottenuto la certificazione ISO9001 e da allora aggiorniamo costantemente i nostri standard di produzione per garantire l'adeguatezza di impianti, processi e prodotti. In quest'ottica le nostre linee residenziali sono coperte da una garanzia di ben 5 anni.

*We keep our quality level high: in relation to each reference standard we boast the appropriate certificates thanks to **monitoring constant on materials and production**. Our internal laboratory carries out all necessary tests to guarantee compliance with all regulations. In 1998 we obtained ISO9001 certification, and from then we update constantly our production standards to ensure the adequacy of systems, processes and products. In this context these residential series are covered by a 5 years warranty.*

 **5 ANNI GARANZIA**
YEARS WARRANTY

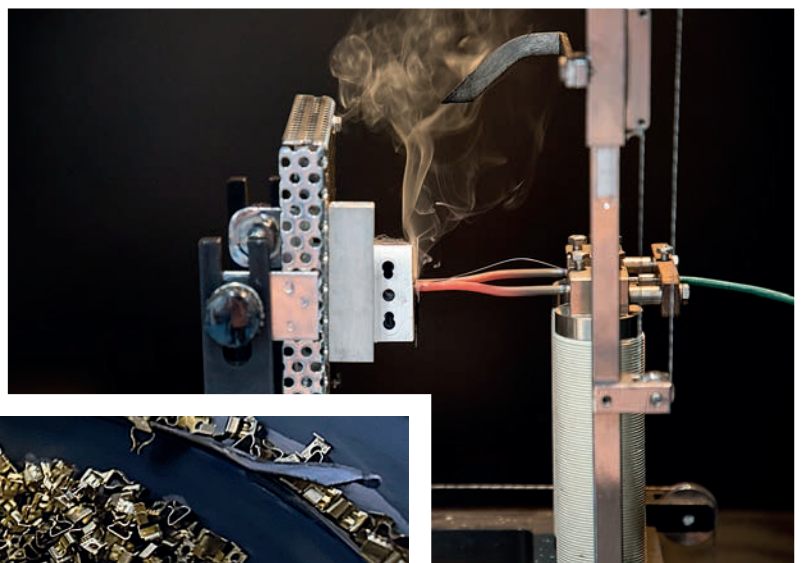
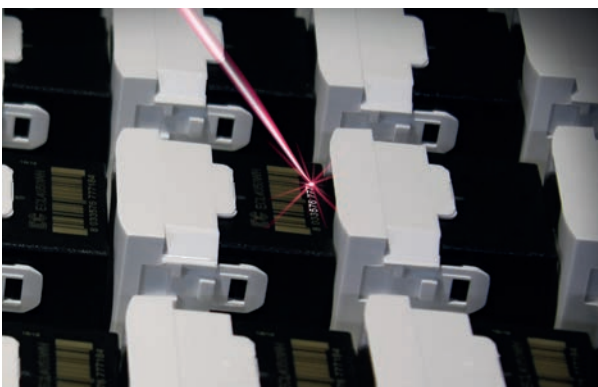

my **life**®



MYLIFE® APPARECCHI MODULARI FINITURA TEC
MYLIFE® MODULAR DEVICES TEC FINISHING

8



MYLIFE® APPARECCHI MODULARI FINITURA BIANCA
MYLIFE® MODULAR DEVICES WHITE FINISHING

18



MYLIFE® APPARECCHI MODULARI FINITURA GRIGIA
MYLIFE® MODULAR DEVICES GREY FINISHING

28

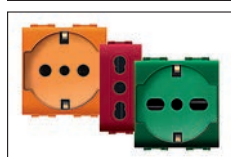

MYLIFE® PRESE PER IMPIANTI DEDICATI
MYLIFE® OUTLET SOCKETS FOR DEDICATED EQUIPMENT

38



MYLIFE® ANTIBATTERICA
MYLIFE® ANTIBACTERIAL

40



MYLIFE® APPARECCHI DI ILLUMINAZIONE D'EMERGENZA
MYLIFE® EMERGENCY LIGHTING DEVICES

44



MYLIFE® PLACCHE COPRINTERRUTTORI
MYLIFE® COVER PLATES

48

my **life**®



MYLIFE® APPLICAZIONE SU SCATOLA TONDA ED INTERNAZIONALE 56
MYLIFE® APPLICATION ON ROUND AND INTERNATIONAL BOX



MYLIFE Q® PLACCHE COPRINTERRUTTORI
MYLIFE Q® COVER PLATES

60

my **life**Q®



NEW PRESTIGE® PLACCHE COPRINTERRUTTORI
NEW PRESTIGE® COVER PLATES

66

new
Prestige®



MYLIFE® BOX SYSTEM
MYLIFE® BOX SYSTEM

74

		<p>SISTEMA PER IMPIANTI DEDICATI: Sistema di chiamata ospedaliero/alberghiero SYSTEMS FOR DEDICATED EQUIPMENT Medical/hotel calling system</p>	<p>78</p>
		<p>EASY APPARECCHI MODULARI EASY MODULAR DEVICES</p>	<p>84</p>
		<p>EASY PLACCHE COPRINTERRUTTORI EASY COVER PLATES</p>	<p>92</p>
		<p>EASY BOX SYSTEM EASY BOX SYSTEM</p>	<p>95</p>
		<p>TONDÒ® APPARECCHI MODULARI TONDÒ® MODULAR DEVICES</p>	<p>96</p>
		<p>TONDÒ® PLACCHE COPRINTERRUTTORI TONDÒ® COVER PLATES</p>	<p>102</p>
		<p>TONDÒ Q PLACCHE COPRINTERRUTTORI TONDÒ Q COVER PLATES</p>	<p>106</p>
		<p>TONDÒ Q BOX SYSTEM TONDÒ Q BOX SYSTEM</p>	<p>110</p>
		<p>TRASFORMATORI ED APPARECCHI AUSILIARI GUIDA DIN DIN BAR TRANSFORMERS AND ADDITIONAL DEVICES</p>	<p>114</p>
		<p>APPENDICE TECNICA TECHNICAL DOCUMENTS</p>	<p>118</p>
		<p>STRUMENTI DI MARKETING MARKETING TOOLS</p>	<p>134</p>





my life®

Apparecchi modulari Finitura TEC

Dall'evoluzione della serie MYLIFE® nasce la serie di apparecchi modulari MYLIFE® TEC.

Sviluppata da un team di specialisti, sempre attento ad intercettare ed assecondare le richieste del mercato, la MYLIFE® TEC è la massima espressione sia in termini di estetica che di qualità.

Il colore argento con finitura satinata conferisce a questi apparecchi un'eleganza notevole ma sempre discreta adatta ad impreziosire ogni ambiente, a prescindere dal tipo d'arredamento.

Modular devices TEC finishing

MYLIFE® TEC is the new series of modular devices realised by the evolution of MYLIFE® series.

MYLIFE® TEC, developed by team of specialists, everyday looking out for the different needs of the contemporary market, to anticipate and comply with the new trends, is best expression of design and quality.

This series, thanks to the silver colour with satin finish, has an elegance and pleasant design, that enriches several different places, notwithstanding any kind of furniture.



APPARECCHI DI COMANDO BASE BASIC SWITCHING DEVICES



ECL4000 TEC

Interruttore unipolare
1 way single pole switch

CONFEZ. BOX 12 pz
IMBALLO PACKAGE 240 pz
16AX 250V~



ECL4003 TEC

Deviatore unipolare
2 way single pole switch

CONFEZ. BOX 12 pz
IMBALLO PACKAGE 240 pz
16AX 250V~



ECL4006 TEC

Invertitore unipolare
Intermediate single pole switch

CONFEZ. BOX 12 pz
IMBALLO PACKAGE 240 pz
16AX 250V~



ECL4009 TEC

Interruttore bipolare
1 way double pole switch

CONFEZ. BOX 12 pz
IMBALLO PACKAGE 240 pz
16AX 250V~



ECL4021 TEC

Pulsante unipolare generico
Push button

CONFEZ. BOX 12 pz
IMBALLO PACKAGE 240 pz
16A 250V~ 1P/NO



ECL4021 NCTEC

Pulsante unipolare
normalmente chiuso
Normally closed
push button

CONFEZ. BOX 12 pz
IMBALLO PACKAGE 240 pz
16A 250V~ 1P/NC



ECL4020 TEC

Commutatore 1P
con OFF centrale (1-0-2)
2 way 1P switch
with central OFF position (1-0-2)

CONFEZ. BOX 12 pz
IMBALLO PACKAGE 240 pz
16AX 250V~
Specifiche tecniche a pag. 119
Technical features page 119



ECL4022 TEC

Doppio pulsante interbloccato
(1P/NO)+(1P/NO)
Interlocked twin single pole push button
(1P/NO)+(1P/NO)

CONFEZ. BOX 12 pz
IMBALLO PACKAGE 240 pz
10A 250V~
Specifiche tecniche a pag. 119
Technical features page 119



ECL4023 TEC

Doppio pulsante
(1P/NO)+(1P/NO)
Twin single pole push button
(1P/NO)+(1P/NO)

CONFEZ. BOX 12 pz
IMBALLO PACKAGE 240 pz
10A 250V~
Specifiche tecniche a pag. 119
Technical features page 119



ECL4024 TEC

Pulsante unipolare a tirante
Push button with cord

CONFEZ. BOX 6 pz
IMBALLO PACKAGE 120 pz
Lunghezza cordino 1,5 m
Cord length 1,5 m
16A 250V~ 1P/NO

APPARECCHI DI COMANDO ILLUMINABILI LIGHTABLE SWITCHING DEVICES

Specifiche tecniche a pag. 119
Technical features page 119



ECL4012 TEC

Interruttore unipolare illuminabile
(lampada spia non inclusa)
Lightable 1 way single pole switch
(indicator lamp not supplied)

CONFEZ. BOX 12 pz
IMBALLO PACKAGE 240 pz
16AX 250V~



ECL4013 TEC

Deviatore unipolare illuminabile
(lampada spia non inclusa)
Lightable 2 way single pole switch
(indicator lamp not supplied)

CONFEZ. BOX 12 pz
IMBALLO PACKAGE 240 pz
16AX 250V~



ECL4016 TEC

Invertitore unipolare illuminabile
(lampada spia non inclusa)
Lightable intermediate
single pole switch
(indicator lamp not supplied)

CONFEZ. BOX 12 pz
IMBALLO PACKAGE 240 pz
16AX 250V~



ECL4015 TEC

Interruttore bipolare illuminabile
(lampada spia non inclusa)
Lightable 1 way double pole switch
(indicator lamp not supplied)

CONFEZ. BOX 12 pz
IMBALLO PACKAGE 240 pz
16AX 250V~



ECL4018 TEC

Pulsante unipolare illuminabile
(lampada spia non inclusa)
Lightable push button
(indicator lamp not supplied)

CONFEZ. BOX 12 pz
IMBALLO PACKAGE 240 pz
16A 250V~ 1P/NO



ECL4000 LN

Lampada spia cavo mm 100
Indicator neon lamp
with 100 mm cable

CONFEZ. BOX 50 pz
IMBALLO PACKAGE 1000 pz
Colore neon: blu
Neon color: blue
230V~ 0,5W max 2mA max



ECL4000 LD

Lampada spia a LED cavo mm 100
Indicator LED lamp
with 100 mm cable

CONFEZ. BOX 50 pz
IMBALLO PACKAGE 1000 pz
Colore LED: blu
LED color: blue
230V~ 0,125W 0,5mA max



ECL4000 LD12

Lampada spia a LED cavo mm 100
Indicator LED lamp
with 100 mm cable

CONFEZ. BOX 50 pz
IMBALLO PACKAGE 1000 pz
Colore LED: blu
LED color: blue
12/24V~ 0,025W max 1mA max

PRESE DI CORRENTE OUTLET SOCKETS



ECL4039 TEC

Presse italiana con sicurezza
Italian shuttered socket

CONFEZ. BOX 12 pz
IMBALLO PACKAGE 240 pz

CE
10A 250V~
2P + ⊕
Standard P11



ECL4045 TEC

Presse italiana bivalente con sicurezza
Italian double shuttered socket

CONFEZ. BOX 12 pz
IMBALLO PACKAGE 240 pz

CE
10/16A 250V~
2P + ⊕
Standard P17/P11



ECL4046 TEC

Presse italiana con sicurezza
2 moduli
*Italian shuttered socket
2 modules*

CONFEZ. BOX 6 pz
IMBALLO PACKAGE 120 pz

CE
16A 250V~
2P + ⊕ centrale/central
Standard P30



ECL4050 TEC

Presse italiana/tedesca trivalente con sicurezza
2 moduli
*Italian/German triple shuttered socket
2 modules*

CONFEZ. BOX 6 pz
IMBALLO PACKAGE 120 pz

CE
10/16A 250V~
2P + ⊕ centrale/central
Standard P40

PRESE STANDARD INTERNAZIONALI INTERNATIONAL STANDARD SOCKETS



ECL4037 TEC

Presse americana
American socket

CONFEZ. BOX 12 pz
IMBALLO PACKAGE 240 pz

CE
15A 127V~
2P + ⊕



ECL4038 TEC

Presse euroamericana
Euroamerican socket

CONFEZ. BOX 12 pz
IMBALLO PACKAGE 240 pz

CE
16A 127/250V~
2P



ECL4049 TEC

Presse euroamericana con sicurezza
Euroamerican shuttered socket

CONFEZ. BOX 12 pz
IMBALLO PACKAGE 240 pz

CE
16A 127/250V~
2P



ECL4040 TEC

Presse euroamericana
Euroamerican socket

CONFEZ. BOX 12 pz
IMBALLO PACKAGE 240 pz

CE
16A 127/250V~
2P + ⊕



ECL4042 TEC

Presse euroamericana duplex - 3 moduli
Euroamerican duplex socket - 3 modules

CONFEZ. BOX 4 pz
IMBALLO PACKAGE 80 pz

CE
16A 127/250V~
2P + ⊕



ECL4044 TEC

Presse francese con sicurezza
2 moduli
*French shuttered socket
2 modules*

CONFEZ. BOX 6 pz
IMBALLO PACKAGE 120 pz

CE
16A 250V~
2P + ⊕



ECL4047 TEC

Presse tedesca con sicurezza
2 moduli
*German shuttered socket
2 modules*

CONFEZ. BOX 6 pz
IMBALLO PACKAGE 120 pz

CE
16A 250V~
2P + ⊕ centrale/central
Standard P30



ECL4041 TEC

Presse inglese con sicurezza
2 moduli
*English shuttered socket
2 modules*

CONFEZ. BOX 6 pz
IMBALLO PACKAGE 120 pz

CE
13A 250V~
2P + ⊕

DISPOSITIVI DI SICUREZZA SAFETY DEVICES

Specifiche tecniche a pag. 120, 121
Technical features page 120, 121



ECL4043 TEC

Limitatore di sovratensione
Voltage surge limiter

CONFEZ. BOX 6 pz
IMBALLO PACKAGE 120 pz

CE
250 V~ Classe II
Tensione massima di protezione 1kV
Potere di scarica 4,5 kA (8/20 μs)
Energia dissipabile 72 J (2 ms)
250 V~ II Class
Max voltage of protection 1kV
Discharge power 4,5 kA (8/20 μs)
Dissipate energy 72J (2ms)



ECL4400 TEC

Interruttore automatico magnetotermico C10 - 1 modulo
Thermal-magnetic automatic switch C10 - 1 module

CONFEZ. BOX 6 pz
IMBALLO PACKAGE 120 pz

CE
1P + N
Potere di interruzione: 3kA
Breaking power: 3kA



ECL4401 TEC

Interruttore automatico magnetotermico C16 - 1 modulo
Thermal-magnetic automatic switch C16 - 1 module

CONFEZ. BOX 6 pz
IMBALLO PACKAGE 120 pz

CE
1P + N
Potere di interruzione: 3kA
Breaking power: 3kA



ECL4402 TEC

Interruttore automatico magnetotermico differenziale C10 - 2 moduli
Differential thermal-magnetic automatic switch C10 - 2 modules

CONFEZ. BOX 3 pz
IMBALLO PACKAGE 60 pz

CE
1P + N - 10mA
Potere di interruzione: 3kA
Breaking power: 3kA

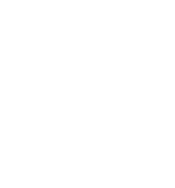

ECL4403 TEC

Interruttore automatico magnetotermico differenziale C16 - 2 moduli
Differential thermal-magnetic automatic switch C16 - 2 modules

CONFEZ. BOX 3 pz
IMBALLO PACKAGE 60 pz

CE
1P + N - 10mA
Potere di interruzione: 3kA
Breaking power: 3kA

PRESE TELEFONICHE E TRASMISSIONE DATI TELEPHONE AND DATA SOCKETS

Specifiche tecniche a pag. 122, 123, 124
Technical features page 122, 123, 124



ECL4084 TEC

Presca telefonica RJ11 plug 6/4
RJ11 telephone socket

CONFEZ. BOX 12 pz
IMBALLO PACKAGE 240 pz



ECL4082 TEC

Presca telefonica RJ11 plug 6/4
RJ12 plug 6/6 autocrimpante
Self-crimping telephone socket
RJ11 plug 6/4 RJ12 plug 6/6

CONFEZ. BOX 6 pz
IMBALLO PACKAGE 120 pz



ECL4083 TEC

Presca RJ45 cat 5e UTP
non schermata autocrimpante
Self-crimping RJ45 socket cat 5e UTP

CONFEZ. BOX 6 pz
IMBALLO PACKAGE 120 pz



ECL4085 TEC

Presca RJ45 cat 5e FTP
schermata autocrimpante
Self-crimping RJ45 socket cat 5e FTP

CONFEZ. BOX 6 pz
IMBALLO PACKAGE 120 pz



ECL4087 TEC

Presca RJ45 cat 6 UTP
non schermata autocrimpante
Self-crimping RJ45 socket cat 6 UTP

CONFEZ. BOX 6 pz
IMBALLO PACKAGE 120 pz



ECL4086 TEC

Presca RJ45 cat 6 FTP
schermata autocrimpante
Self-crimping RJ45 socket cat 6 FTP

CONFEZ. BOX 6 pz
IMBALLO PACKAGE 120 pz



ECL4081 TEC

Alimentatore USB tipo A da incasso
Aggancio Keystone
USB charger A type
Keystone docking

CONFEZ. BOX 6 pz
IMBALLO PACKAGE 120 pz



Tensione alimentazione In: 100-240V~ 50/60Hz
Tensione alimentazione Out: 5Vdc 2.1A
Input: 100-240V~ 50/60Hz
Output: 5Vdc 2.1A



ECL4081C TEC

Alimentatore USB tipo C da incasso
Aggancio Keystone
USB charger C type
Keystone docking

CONFEZ. BOX 6 pz
IMBALLO PACKAGE 120 pz



Tensione alimentazione In: 100-240V~ 50/60Hz
Tensione alimentazione Out: 5Vdc 2.1A
Input: 100-240V~ 50/60Hz
Output: 5Vdc 2.1A



ECL4089 TEC

Presca standard USB aggancio Keystone
USB standard socket - Keystone docking

CONFEZ. BOX 6 pz
IMBALLO PACKAGE 120 pz



ECL408301 TEC

Adattatore Keystone
connettore telefonia/dati
Keystone adapter
telephone/data connector

CONFEZ. BOX 32 pz
IMBALLO PACKAGE 640 pz



PRESE TV E SAT TELEVISION AND SATELLITE SOCKETS

Specifiche tecniche a pag. 125
Technical features page 125



ECL2048 3

Resistenza terminale
di chiusura linea prese TV
impedenza 75 Ohm
Terminal closing TV socket line
impedance 75 Ohm

CONFEZ. BOX 20 pz



ECL4048 1 TEC

Presca coassiale TV
DIRETTA per impianti monoutenza
PASSANTE per impianti a cascata
TERMINATA con collegamento
all'art. ECL20483 per impianti a cascata

CONFEZ. BOX 12 pz
IMBALLO PACKAGE 240 pz



TV socket
DIRECT for single user system
PASSING for system with fall distribution
TERMINAL connected with art. ECL20483
for system with fall distribution

Connettore femmina D mm 9,5
Attenuazione di passaggio 0 dB
VHF-UHF (40-860MHz)



ECL4048 1M TEC

Presca coassiale TV
DIRETTA per impianti monoutenza
PASSANTE per impianti a cascata
TERMINATA con collegamento
all'art. ECL20483 per impianti a cascata

CONFEZ. BOX 12 pz
IMBALLO PACKAGE 240 pz



TV socket
DIRECT for single user system
PASSING for system with fall distribution
TERMINAL connected with art. ECL20483
for system with fall distribution

Connettore maschio
Attenuazione di passaggio 0 dB
VHF-UHF (40-860MHz)



PRESE TV E SAT TELEVISION AND SATELLITE SOCKETS *Specifiche tecniche a pag. 125
Technical features page 125*



ECL4051 TEC

Presse coassiale ULB diretta
Direct ULB socket



Connettore maschio (CEI EN 61169-2)
Totalmente schermata
per impianti tradizionali e satellitari
Attenuazione 0 dB - 5-2400MHz - Classe A
*Male connector (CEI EN 61169-2)
Totally shielded for TV and SAT systems
Signal attenuation 0 dB - 5-2400MHz - A class*

CONF.
BOX 12 pz
IMBALLO
PACKAGE 240 pz



ECL4054 TEC

Presse coassiale ULB passante
Attenuazione 4 dB
*Passing ULB socket
Signal attenuation 4 dB*

CONF.
BOX 12 pz
IMBALLO
PACKAGE 240 pz

ECL4055 TEC

Presse coassiale ULB passante
Attenuazione 7 dB
*Passing ULB socket
Signal attenuation 7 dB*

Connettore maschio (CEI EN 61169-2)
Totalmente schermata per impianti tradizionali e satellitari - 5-2400MHz - Classe A
*Male connector (CEI EN 61169-2)
Totally shielded for TV and SAT systems - 5-2400MHz - A class*

ECL4056 TEC

Presse coassiale ULB passante
Attenuazione 10 dB
*Passing ULB socket
Signal attenuation 10 dB*



ECL4052 SATEC

Presse coassiale TV SAT diretta
Direct TV SAT socket

CONF.
BOX 12 pz
IMBALLO
PACKAGE 240 pz

Connettore femmina (IEC 60169-24)
Totalmente schermata
per impianti tradizionali e satellitari
Attenuazione 0 dB
TV-SAT (5-2400MHz) - Classe A
*Female connector (IEC 60169-24)
Totally shielded for TV and SAT systems
Signal attenuation 0 dB
TV-SAT (5-2400MHz) - A class*



ECL4057 SATEC

Presse coassiale TV SAT passante
Passing TV SAT socket



Connettore femmina (IEC 60169-24)
Totalmente schermata
per impianti tradizionali e satellitari
Attenuazione 4 dB
TV-SAT (5-2400MHz) - Classe A
*Female connector (IEC 60169-24)
Totally shielded for TV and SAT systems
Signal attenuation 4 dB
TV-SAT (5-2400MHz) - A class*

CONF.
BOX 12 pz
IMBALLO
PACKAGE 240 pz



ECL4058 FMSATEC

Presse 3 porte TV-FM-SAT diretta
Direct TV-FM-SAT triplex socket

CONF.
BOX 6 pz
IMBALLO
PACKAGE 120 pz



ECL4053 SATEC

Presse coassiale SAT tipo F
TV SAT socket F-type

CONF.
BOX 12 pz
IMBALLO
PACKAGE 240 pz

Connettore femmina (IEC 60169-24)
max 2400MHz
*Female connector (IEC 60169-24)
max 2400MHz*



ECL4100 TEC

Presse DEMIX TV-SAT diretta
Direct DEMIX TV-SAT socket



Connettore maschio-femmina
Totalmente schermata
per impianti tradizionali e satellitari
Attenuazione 0 dB
5-2150MHz - Classe A
*Male and female socket
Totally shielded for TV and SAT systems
Signal attenuation 0 dB
5-2150MHz - A class*

CONF.
BOX 12 pz
IMBALLO
PACKAGE 240 pz



ECL4101 TEC

Presse DEMIX TV-SAT passante
Passing DEMIX TV-SAT socket



Connettore maschio-femmina
Totalmente schermata
per impianti tradizionali e satellitari
Attenuazione 4 dB
5-2150MHz - Classe A
*Male and female socket
Totally shielded for TV and SAT systems
Signal attenuation 4 dB
5-2150MHz - A class*

CONF.
BOX 12 pz
IMBALLO
PACKAGE 240 pz



ECL4088 TEC

Presse standard HDMI aggancio Keystone con 10 cm di cavo
HDMI standard socket - Keystone docking with 10 cm cable

CONF.
BOX 6 pz
IMBALLO
PACKAGE 120 pz



APPARECCHI DI COMANDO SPECIALI SPECIAL DEVICES



ECL4025 TEC

Pulsante con portanome
Name holder push button

CONF.
BOX 6 pz
IMBALLO
PACKAGE 120 pz



ECL4061 TEC

Interruttore unipolare con chiave
Estrazione chiave in posizione ON e OFF
*1 way single pole switch with key
Key extraction in ON and OFF position*

CONF.
BOX 12 pz
IMBALLO
PACKAGE 240 pz



ECL4061 UNETEC

Interruttore unipolare con chiave unificata
Estrazione chiave solo in OFF
*1 way single pole switch with unified key
Key extraction only in OFF position*

CONF.
BOX 6 pz
IMBALLO
PACKAGE 120 pz



ECL4061U TEC

Interruttore unipolare con chiave unificata
Estrazione chiave in posizione ON e OFF
*1 way single pole switch with unified key
Key extraction in ON and OFF position*

CONF.
BOX 6 pz
IMBALLO
PACKAGE 120 pz



ECL4065 TEC

Interruttore automatico ad infrarosso passivo
Passive infra-red automatic switch

CONF.
BOX 1 pz

230V~ C.o. ± 10% 50 Hz
Relè 5A/250V~ uscita a corrente limitata con resistenza per ZERO CROSSING di elevato valore
Lampade incandescenza 800W
Lampade fluorescenti 200W CFL6
Regolazione temporizzazione:
minimo circa 5 sec. - 12min.
Regolazione luminosità: da circa 5 a circa 200 LUX
Angolo di rilevamento: fino a 110° a 20°C
Campo di rilevamento: circa 8mt a 20°C
*230V~ C.o. ± 10% 50 Hz
Relè 5A/250V~ output voltage limited to ZERO CROSSING
Incandescent lamp 800W
Fluorescent lamp 200W CFL6
Delay time adjustable:
min. 5 sec. about - 12min.
Brightness control: from 5 to 200 LUX about
Detection angle: until to 110° to 20°C
Detection distance: 8mt about to 20°C*

*Specifiche tecniche a pag. 126
Technical features page 126*

APPARECCHI DI COMANDO ELETTRONICI ELECTRONIC DEVICES



ECL4062L

Cronotermostato settimanale digitale 3 moduli da incasso alimentato a batterie predisposto con supporto di aggancio e 3 covers colorate
3 modules weekly digital thermostat batteries power supply with wall frame and 3 coloured covers included

CONFEZ. BOX 1 pz



Alimentazione 2 batterie 1,5V~
Scala di regolazione temperatura da 2° a 40 °C
Differenziale 0,25K
Power supply 2 batteries 1,5V~
Temperature adjustment range from 2° to 40 °C
Differential 0,25K

Specifiche tecniche a pag. 127
Technical features page 127



ECL4063L TEC

Termostato ambiente elettronico 3 moduli da incasso alimentato a batterie predisposto con supporto di aggancio
3 modules electronic thermostat batteries power supply with wall frame and 3 coloured covers included

CONFEZ. BOX 1 pz



Alimentazione 3 batterie 1,5V~
Scala di regolazione temperatura da 5° a 30 °C
Power supply 3 batteries 1,5V~
Temperature adjustment range from 5° to 30 °C

Specifiche tecniche a pag. 127
Technical features page 127



ECL4026

Interruttore a badge 3 moduli predisposto con supporto di aggancio
3 modules badge switch with wall frame included

CONFEZ. BOX 1 pz



Input 24Vdc - Output 3A 250V~
Tempo di cortesia programmabile da 10s a 30s
Illuminazione della tasca con led blu per individuazione al buio
Compatibile con tessere transponder utilizzate da sistemi di serratura elettronica per hotel:
CISA, SALTO, Vingcard/Assa Abloy, Dormakaba
Fornito con tessera transponder
Input 24Vdc - Output 3A 250V~
Programmable courtesy time from 10s to 30s
Blue led light in the card insertion slot for identification in the dark
Compatible with transponder cards used by electronic lock systems for hotel:
CISA, SALTO, Vingcard/Assa Abloy, Dormakaba
Transponder card supplied

Specifiche tecniche a pag. 128
Technical features page 128



ECL4026T

Tessera transponder Mifare
Mifare transponder card

CONFEZ. BOX 1 pz

Stampa opzionale
Immagine puramente indicativa
Optional print
Purely indicative image



Standard ISO/IEC 14443A/B
13,56 MHz (RFID frequency)
colore bianco
ISO/IEC 14443A/B standard
13,56 MHz (RFID frequency)
white color

Specifiche tecniche a pag. 128
Technical features page 128

Specifiche tecniche a pag. 128
Technical features page 128

Specifiche tecniche a pag. 129
Technical features page 129



ECL4026A

Alimentatore 230V~ per interruttore badge (ECL4026)
230V~ power supply for badge switch (ECL4026)

CONFEZ. BOX 1 pz



Specifiche tecniche a pag. 129, 130
Technical features page 129, 130



PER LAMPADINE A LED
LED LAMPS

ECL4705 TEC

Variatore di luminosità universale con deviatore push-push per led dimmerabili e carichi resistivi/induttivi con punto luminoso rosso per individuazione al buio
Universal dimmerable led light and resistive/inductive dimmer with 2 way single pole switch. Push action. Red indicator light in the front side

CONFEZ. BOX 6 pz

IMBALLO PACKAGE 120 pz

Led dimmerabili/dimmerable led 4W-80W
Resistivi/Resistive 20W-150W
Induttivi/Inductive 20VA-100VA



ECL4701 TEC

Variatore di luminosità con deviatore push-push per carichi resistivi con punto luminoso rosso per individuazione al buio
Resistive light dimmer with 2 way single pole switch. Push action. Red indicator light in the front side

CONFEZ. BOX 6 pz

IMBALLO PACKAGE 120 pz



100-500W 230V~



ECL4702 TEC

Variatore di luminosità con deviatore push-push per carichi induttivi con punto luminoso rosso per individuazione al buio
Inductive light dimmer with 2 way single pole switch. Push action. Red indicator light in the front side

CONFEZ. BOX 6 pz

IMBALLO PACKAGE 120 pz



40-160 VA 230V~



ECL4703 TEC

Variatore di luminosità rotativo per carichi resistivi con punto luminoso rosso per individuazione al buio
Resistive revolving light dimmer with 1 way single pole switch. Red indicator light in the front side

CONFEZ. BOX 6 pz

IMBALLO PACKAGE 120 pz



100-500W 230V~



ECL4704 TEC

Variatore di luminosità rotativo per carichi induttivi con punto luminoso rosso per individuazione al buio
Inductive revolving light dimmer with 1 way single pole switch. Red indicator light in the front side

CONFEZ. BOX 6 pz

IMBALLO PACKAGE 120 pz



40-160 VA 230 V~

APPARECCHI DI SEGNALAZIONE ACUSTICA E LUMINOSA SOUND AND LIGHT SIGNALLING DEVICES



ECL4072 1TEC 12V~ 50Hz 8VA max

Suoneria
Bell
Funzionamento intermittente 5/15:
l'emissione sonora può durare
fino a 5s max, seguita da
un periodo di riposo di 15s.

*Intermittent sound 5/15:
the sound emission can last up
to max 5 seconds, followed by
a period at rest of 15 seconds.*

CONF. BOX 12 pz
IMBALLO PACKAGE 240 pz



ECL4072 10TEC 220V~ 50Hz 8VA max

Suoneria
Bell
Funzionamento intermittente 5/15:
l'emissione sonora può durare
fino a 5s max, seguita da
un periodo di riposo di 15s.

*Intermittent sound 5/15:
the sound emission can last up
to max 5 seconds, followed by
a period at rest of 15 seconds.*

CONF. BOX 12 pz
IMBALLO PACKAGE 240 pz



ECL4075 1TEC 12V~ 50Hz 8VA max

Ronzatore
Buzzer
Funzionamento intermittente 5/15:
l'emissione sonora può durare
fino a 5s max, seguita da
un periodo di riposo di 15s.

*Intermittent sound 5/15:
the sound emission can last up
to max 5 seconds, followed by
a period at rest of 15 seconds.*

CONF. BOX 12 pz
IMBALLO PACKAGE 240 pz



ECL4075 10TEC 220V~ 50Hz 8VA max

Ronzatore
Buzzer
Funzionamento intermittente 5/15:
l'emissione sonora può durare
fino a 5s max, seguita da
un periodo di riposo di 15s.

*Intermittent sound 5/15:
the sound emission can last up
to max 5 seconds, followed by
a period at rest of 15 seconds.*

CONF. BOX 12 pz
IMBALLO PACKAGE 240 pz



ECL4066

Diffusore notturno a LED 3 moduli predisposto con supporto di aggancio
compatibile con le placche MYLIFE® - MYLIFE Q® - NEW PRESTIGE®
3 modules LED night diffuser with wall frame included
compatible with MYLIFE® - MYLIFE Q® - NEW PRESTIGE® cover plates

CONF. BOX 1 pz
IMBALLO PACKAGE 20 pz



230V~ 50Hz
Lampada:
3 LEDS colore bianco
Intensità luminosa:
> 12.000 mcd @ 20mA
Temperatura di
funzionamento: 0° + 40°C
230V~ 50Hz
Bulb: 3 LEDS white colour
Brightness: > 12.000 mcd @ 20mA
Working temperature: 0° + 40°C



ECL40661 TEC

Diffusore notturno a LED
1 modulo aggancio KEYSTONE
1 module LED night diffuser
KEYSTONE docking

CONF. BOX 6 pz
IMBALLO PACKAGE 30 pz



230V~ 50Hz
Lampada 1 LED colore bianco
Intensità luminosa:
> 1800 mcd @ 3.7mA
Funzioni: ON (SA) - AUTO (SE)
Temperatura di
funzionamento: -10° + 40°
230V~ 50Hz
Bulb: 1 LED WHITE COLOUR
Brightness: > 1800 mcd @ 3.7mA
Function: ON (SA) - AUTO (SE)
Working temperature: -10° + 40°



ECL4076

Segnalatore ottico/acustico per chiamate di emergenza
predisposto con supporto di aggancio e placca
compatibile con le placche MYLIFE® - MYLIFE Q® - NEW PRESTIGE®
Optical/acoustic indicator device for emergency calls
with wall frame and cover plate included
compatible with MYLIFE® - MYLIFE Q® - NEW PRESTIGE® cover plates

CONF. BOX 1 pz
IMBALLO PACKAGE 18 pz

Alimentazione: 12-24V~
tramite trasformatore di sicurezza
Consumo max: 2W
Segnalazione luminosa:
LED rosso alta luminosità
Segnalazione Acustica:
1 ronzatore Piezo 95dB ad 1 mt
Power supply: 12-24V~
through safety transformer
Max power consumption: 2W
Light signal: red LED
Sound signal: Buzzer Piezo 95dB 1mt far

Specifiche tecniche a pag. 131
Technical features page 131



ECL4077

Segnalatore ottico/acustico per chiamate di emergenza
predisposto con supporto di aggancio e placca - Funzionamento autonomo
compatibile con le placche MYLIFE® - MYLIFE Q® - NEW PRESTIGE®
Optical/acoustic indicator device for emergency calls
with wall frame and cover plate included - Independent operation
compatible with MYLIFE® - MYLIFE Q® - NEW PRESTIGE® cover plates

CONF. BOX 1 pz
IMBALLO PACKAGE 18 pz

Alimentazione: 12-24V~
tramite trasformatore di sicurezza
Consumo max: 2W
Segnalazione luminosa:
LED rosso alta luminosità
Segnalazione Acustica:
1 ronzatore Piezo 95dB ad 1 mt
Power supply: 12-24V~
through safety transformer
Max power consumption: 2W
Light signal: red LED
Sound signal: Buzzer Piezo 95dB 1mt far

Specifiche tecniche a pag. 132
Technical features page 132

COPRITASTI INTERCAMBIABILI 1 MODULO 1 MODULE INTERCHANGEABLE COVERS



ECL4080 TEC

Falso polo
Blank cap

CONFEZ.
BOX 32 pz
IMBALLO
PACKAGE 640 pz



ECL4080 2TEC

Falso polo con uscita Ø9 mm
Blank cap with Ø9 mm hole

CONFEZ.
BOX 32 pz
IMBALLO
PACKAGE 640 pz



ECL4090 3TEC

Copritasto singolo
Key cover

CONFEZ.
BOX 50 pz
IMBALLO
PACKAGE 1000 pz



ECL4090 4TEC

Copritasto singolo illuminabile
Lightable key cover

CONFEZ.
BOX 50 pz
IMBALLO
PACKAGE 1000 pz



ECL4090 5TEC

Copritasto singolo
per interruttore bipolare
Key cover for 1 way
double poles switch

CONFEZ.
BOX 50 pz
IMBALLO
PACKAGE 1000 pz



ECL4090 6TEC

Copritasto singolo illuminabile
per interruttore bipolare
Lightable key cover for 1 way
double poles switch

CONFEZ.
BOX 50 pz
IMBALLO
PACKAGE 1000 pz



ECL4090 7TEC

Copritasto singolo
per pulsante generico
Key cover
for push button

CONFEZ.
BOX 50 pz
IMBALLO
PACKAGE 1000 pz



ECL4090 8TEC

Copritasto singolo illuminabile
per pulsante generico
Lightable key cover
for push button

CONFEZ.
BOX 50 pz
IMBALLO
PACKAGE 1000 pz



ECL4090 9TEC

Copritasto
pulsante simbolo chiave
Key cover for push button
with key symbol

CONFEZ.
BOX 50 pz
IMBALLO
PACKAGE 1000 pz



ECL4090 10TEC

Copritasto
pulsante simbolo luce
Key cover for push button
with lamp symbol

CONFEZ.
BOX 50 pz
IMBALLO
PACKAGE 1000 pz



ECL4090 11TEC

Copritasto
pulsante simbolo campanello
Key cover for push button
with bell symbol

CONFEZ.
BOX 50 pz
IMBALLO
PACKAGE 1000 pz



ECL4090 12TEC

Copritasto
pulsante simbolo infermiera
Key cover for push button
with nurse symbol

CONFEZ.
BOX 50 pz
IMBALLO
PACKAGE 1000 pz



COPRITASTI INTERCAMBIABILI 2 MODULI 2 MODULES INTERCHANGEABLE COVERS



ECL4090 13TEC

Copritasto doppio
Double key cover

CONFEZ.
BOX 6 pz
IMBALLO
PACKAGE 120 pz



ECL4090 14TEC

Copritasto doppio illuminabile
Lightable double key cover

CONFEZ.
BOX 6 pz
IMBALLO
PACKAGE 120 pz



ECL4090 15TEC

Copritasto doppio bipolare
Double key cover
for 1 way double poles switch

CONFEZ.
BOX 6 pz
IMBALLO
PACKAGE 120 pz



ECL4090 16TEC

Copritasto doppio bipolare illuminabile
Lightable double key cover
for 1 way double poles switch

CONFEZ.
BOX 6 pz
IMBALLO
PACKAGE 120 pz



COPRITASTI INTERCAMBIABILI 3 MODULI 3 MODULES INTERCHANGEABLE COVERS



ECL4090 17TEC

Copritasto triplo
Triple key cover

CONFEZ.
BOX 4 pz
IMBALLO
PACKAGE 80 pz



ECL4090 18TEC

Copritasto triplo illuminabile
Lightable triple key cover

CONFEZ.
BOX 4 pz
IMBALLO
PACKAGE 80 pz



ECL4090 19TEC

Copritasto triplo bipolare
*Triple key cover
for 1 way double poles switch*

CONFEZ.
BOX 4 pz
IMBALLO
PACKAGE 80 pz



ECL4090 20TEC

Copritasto triplo bipolare illuminabile
*Lightable triple key cover
for 1 way double poles switch*

CONFEZ.
BOX 4 pz
IMBALLO
PACKAGE 80 pz



SUPPORTI A PARETE MYLIFE® MYLIFE® WALL FRAMES



ECL4603F

Supporto 3 moduli con viti
aggancio frutti frontale
*3 modules frame with screws
front docking*

CONFEZ.
BOX 100 pz



ECL4604F

Supporto 4 moduli con viti - aggancio frutti frontale
4 modules frame with screws - front docking

CONFEZ.
BOX 20 pz
IMBALLO
PACKAGE 160 pz



ECL4607F

Supporto 7 moduli con viti - aggancio frutti frontale
7 modules frame with screws - front docking

CONFEZ.
BOX 10 pz
IMBALLO
PACKAGE 80 pz



SUPPORTI PER PROFILATI O PANNELLI PROFILES OR PANELS FRAMES



ECL4609AC

Supporto placca con viti per installazione su profilati o pannelli
1 modulo - Completo di scatola di da incasso dedicata
*Cover plate frame with screws for installation on profiles or panels
1 module - Completed with dedicated wall box*

CONFEZ.
BOX 1 pz
IMBALLO
PACKAGE 25 pz

Colore alluminio chiaro
Light aluminium colour



ECL4609WH

Supporto placca con viti per installazione su profilati o pannelli
1 modulo - Completo di scatola di da incasso dedicata
*Cover plate frame with screws for installation on profiles or panels
1 module - Completed with dedicated wall box*

CONFEZ.
BOX 1 pz
IMBALLO
PACKAGE 25 pz

Colore bianco
White colour



ECL4609N

Supporto placca con viti per installazione su profilati o pannelli
1 modulo - Completo di scatola di da incasso dedicata
*Cover plate frame with screws for installation on profiles or panels
1 module - Completed with dedicated wall box*

CONFEZ.
BOX 1 pz
IMBALLO
PACKAGE 25 pz

Colore nero
Black colour



ADATTATORI E SUPPORTI SPECIALI ADAPTERS AND SPECIAL WALL FRAMES



ECL4608

Adattatore per: 2 moduli Serie myLife
3 moduli Barra Din
*Adapter for: 2 modules myLife Series
3 modules Din Bar*

CONFEZ.
BOX 40 pz





my life®

Apparecchi modulari Finitura Bianca

MYLIFE® è un concetto di vita: quello moderno sempre in continua evoluzione in termini di gusti e di bisogni. In linea con questo principio e a completamento del già vasto sistema MYLIFE®, ecco l'ultima nata: la finitura bianca.

Un tocco di vivacità che illumina ogni ambiente. Effetti cromatici in abbinamento con i molteplici colori delle placche coprinterruttori, un notevole contrasto visivo e la facoltà di distinguersi dando ad ogni spazio il giusto tocco di vita.

Modular devices White finishing

MYLIFE® represents a modern life style: ever-changing in tastes and needs. In line with this concept, to complete MYLIFE® series, is realised the latest series white finishing.

A brightness touch that enlightens any space. Chromatic effects combining with a matched colour range of cover plates, a great visual contrast and the possibility to personalise each places with an appropriate touch of life.



APPARECCHI DI COMANDO BASE BASIC SWITCHING DEVICES



ECL4000 WH

Interruttore unipolare
1 way single pole switch

CONFEZ. BOX 12 pz
IMBALLO PACKAGE 240 pz



ECL4003 WH

Deviatore unipolare
2 way single pole switch

CONFEZ. BOX 12 pz
IMBALLO PACKAGE 240 pz



ECL4006 WH

Invertitore unipolare
Intermediate single pole switch

CONFEZ. BOX 12 pz
IMBALLO PACKAGE 240 pz



ECL4009 WH

Interruttore bipolare
1 way double pole switch

CONFEZ. BOX 12 pz
IMBALLO PACKAGE 240 pz



ECL4021 WH

Pulsante unipolare generico
Push button

CONFEZ. BOX 12 pz
IMBALLO PACKAGE 240 pz



ECL4021 NCWH

Pulsante unipolare
normalmente chiuso
Normally closed
push button

CONFEZ. BOX 12 pz
IMBALLO PACKAGE 240 pz



ECL4020 WH

Commutatore 1P
con OFF centrale (1-0-2)
2 way 1P switch
with central OFF position (1-0-2)

CONFEZ. BOX 12 pz
IMBALLO PACKAGE 240 pz



Specifiche tecniche a pag. 119
Technical features page 119



ECL4022 WH

Doppio pulsante interbloccato
(1P/NO)+(1P/NO)
Interlocked twin single pole push button
(1P/NO)+(1P/NO)

CONFEZ. BOX 12 pz
IMBALLO PACKAGE 240 pz



Specifiche tecniche a pag. 119
Technical features page 119



ECL4023 WH

Doppio pulsante
(1P/NO)+(1P/NO)
Twin single pole push button
(1P/NO)+(1P/NO)

CONFEZ. BOX 12 pz
IMBALLO PACKAGE 240 pz



Specifiche tecniche a pag. 119
Technical features page 119



ECL4024 WH

Pulsante unipolare a tirante
Push button with cord

CONFEZ. BOX 6 pz
IMBALLO PACKAGE 120 pz



Lunghezza cordino 1,5 m
Cord length 1,5 m
16A 250V~ 1P/NO

APPARECCHI DI COMANDO ILLUMINABILI LIGHTABLE SWITCHING DEVICES

Specifiche tecniche a pag. 119
Technical features page 119



ECL4012 WH

Interruttore unipolare illuminabile
(lampada spia non inclusa)
Lightable 1 way single pole switch
(indicator lamp not supplied)

CONFEZ. BOX 12 pz
IMBALLO PACKAGE 240 pz



ECL4013 WH

Deviatore unipolare illuminabile
(lampada spia non inclusa)
Lightable 2 way single pole switch
(indicator lamp not supplied)

CONFEZ. BOX 12 pz
IMBALLO PACKAGE 240 pz



ECL4016 WH

Invertitore unipolare illuminabile
(lampada spia non inclusa)
Lightable intermediate
single pole switch
(indicator lamp not supplied)

CONFEZ. BOX 12 pz
IMBALLO PACKAGE 240 pz



ECL4015 WH

Interruttore bipolare illuminabile
(lampada spia non inclusa)
Lightable 1 way double pole switch
(indicator lamp not supplied)

CONFEZ. BOX 12 pz
IMBALLO PACKAGE 240 pz



ECL4018 WH

Pulsante unipolare illuminabile
(lampada spia non inclusa)
Lightable push button
(indicator lamp not supplied)

CONFEZ. BOX 12 pz
IMBALLO PACKAGE 240 pz



ECL4000 LN

Lampada spia cavo mm 100
Indicator neon lamp
with 100 mm cable

CONFEZ. BOX 50 pz
IMBALLO PACKAGE 1000 pz



Colore neon: blu
Neon color: blue



ECL4000 LD

Lampada spia a LED cavo mm 100
Indicator LED lamp
with 100 mm cable

CONFEZ. BOX 50 pz
IMBALLO PACKAGE 1000 pz



Colore LED: blu
LED color: blue



ECL4000 LD12

Lampada spia a LED cavo mm 100
Indicator LED lamp
with 100 mm cable

CONFEZ. BOX 50 pz
IMBALLO PACKAGE 1000 pz



Colore LED: blu
LED color: blue

PRESE DI CORRENTE OUTLET SOCKETS



ECL4039 WH

Presse italiana con sicurezza
Italian shuttered socket

CONF. BOX 12 pz
IMBALLO PACKAGE 240 pz

CE
10A 250V~
2P + ⊕
Standard P11



ECL4045 WH

Presse italiana bivalente con sicurezza
Italian double shuttered socket

CONF. BOX 12 pz
IMBALLO PACKAGE 240 pz

CE
10/16A 250V~
2P + ⊕
Standard P17/P11



ECL4046 WH

Presse italiana con sicurezza
2 moduli
*Italian shuttered socket
2 modules*

CONF. BOX 6 pz
IMBALLO PACKAGE 120 pz

CE
16A 250V~
2P + ⊕ centrale/central
Standard P30



ECL4050 WH

Presse italiana/tedesca trivalente con sicurezza
2 moduli
*Italian/German triple shuttered socket
2 modules*

CONF. BOX 6 pz
IMBALLO PACKAGE 120 pz

CE
10/16A 250V~
2P + ⊕ centrale/central
Standard P40

PRESE STANDARD INTERNAZIONALI INTERNATIONAL STANDARD SOCKETS



ECL4037 WH

Presse americana
American socket

CONF. BOX 12 pz
IMBALLO PACKAGE 240 pz

CE
15A 127V~
2P + ⊕



ECL4038 WH

Presse euroamericana
Euroamerican socket

CONF. BOX 12 pz
IMBALLO PACKAGE 240 pz

CE
16A 127/250V~
2P



ECL4049 WH

Presse euroamericana con sicurezza
Euroamerican shuttered socket

CONF. BOX 12 pz
IMBALLO PACKAGE 240 pz

CE
16A 127/250V~
2P



ECL4040 WH

Presse euroamericana
Euroamerican socket

CONF. BOX 12 pz
IMBALLO PACKAGE 240 pz

CE
16A 127/250V~
2P + ⊕



ECL4042 WH

Presse euroamericana duplex - 3 moduli
Euroamerican duplex socket - 3 modules

CONF. BOX 4 pz
IMBALLO PACKAGE 80 pz

CE
16A 127/250V~
2P + ⊕



ECL4044 WH

Presse francese con sicurezza
2 moduli
*French shuttered socket
2 modules*

CONF. BOX 6 pz
IMBALLO PACKAGE 120 pz

CE
16A 250V~
2P + ⊕



ECL4047 WH

Presse tedesca con sicurezza
2 moduli
*German shuttered socket
2 modules*

CONF. BOX 6 pz
IMBALLO PACKAGE 120 pz

CE
16A 250V~
2P + ⊕ centrale/central
Standard P30



ECL4041 WH

Presse inglese con sicurezza
2 moduli
*English shuttered socket
2 modules*

CONF. BOX 6 pz
IMBALLO PACKAGE 120 pz

CE
13A 250V~
2P + ⊕

DISPOSITIVI DI SICUREZZA SAFETY DEVICES

Specifiche tecniche a pag. 120, 121
Technical features page 120, 121



ECL4043 WH

Limitatore di sovratensione
Voltage surge limiter

CONF. BOX 6 pz
IMBALLO PACKAGE 120 pz

CE
250 V~ Classe II
Tensione massima di protezione 1kV
Potere di scarica 4,5 kA (8/20 μs)
Energia dissipabile 72 J (2 ms)
250 V~ II Class
Max voltage of protection 1kV
Discharge power 4,5 kA (8/20 μs)
Dissipate energy 72J (2ms)



ECL4400 WH

Interruttore automatico magnetotermico C10 - 1 modulo
Thermal-magnetic automatic switch C10 - 1 module

CONF. BOX 6 pz
IMBALLO PACKAGE 120 pz

CE
1P + N
Potere di interruzione: 3kA
Breaking power: 3kA



ECL4401 WH

Interruttore automatico magnetotermico C16 - 1 modulo
Thermal-magnetic automatic switch C16 - 1 module

CONF. BOX 6 pz
IMBALLO PACKAGE 120 pz

CE
1P + N
Potere di interruzione: 3kA
Breaking power: 3kA



ECL4402 WH

Interruttore automatico magnetotermico differenziale C10 - 2 moduli
Differential thermal-magnetic automatic switch C10 - 2 modules

CONF. BOX 3 pz
IMBALLO PACKAGE 60 pz

CE
1P + N - 10mA
Potere di interruzione: 3kA
Breaking power: 3kA



ECL4403 WH

Interruttore automatico magnetotermico differenziale C16 - 2 moduli
Differential thermal-magnetic automatic switch C16 - 2 modules

CONF. BOX 3 pz
IMBALLO PACKAGE 60 pz

CE
1P + N - 10mA
Potere di interruzione: 3kA
Breaking power: 3kA

PRESE TELEFONICHE E TRASMISSIONE DATI TELEPHONE AND DATA SOCKETS

Specifiche tecniche a pag. 122, 123, 124
Technical features page 122, 123, 124



ECL4084 WH

Presca telefonica RJ11 plug 6/4
RJ11 telephone socket

CONFEZ.
BOX 12 pz
IMBALLO
PACKAGE 240 pz



ECL4082 WH

Presca telefonica RJ11 plug 6/4
RJ12 plug 6/6 autocrimpante
Self-crimping telephone socket
RJ11 plug 6/4 RJ12 plug 6/6

CONFEZ.
BOX 6 pz
IMBALLO
PACKAGE 120 pz



ECL4083 WH

Presca RJ45 cat 5e UTP
non schermata autocrimpante
Self-crimping RJ45 socket cat 5e UTP

CONFEZ.
BOX 6 pz
IMBALLO
PACKAGE 120 pz



ECL4085 WH

Presca RJ45 cat 5e FTP
schermata autocrimpante
Self-crimping RJ45 socket cat 5e FTP

CONFEZ.
BOX 6 pz
IMBALLO
PACKAGE 120 pz



ECL4087 WH

Presca RJ45 cat 6 UTP
non schermata autocrimpante
Self-crimping RJ45 socket cat 6 UTP

CONFEZ.
BOX 6 pz
IMBALLO
PACKAGE 120 pz



ECL4086 WH

Presca RJ45 cat 6 FTP
schermata autocrimpante
Self-crimping RJ45 socket cat 6 FTP

CONFEZ.
BOX 6 pz
IMBALLO
PACKAGE 120 pz



ECL4081 WH

Alimentatore USB tipo A da incasso
Aggancio Keystone
USB charger A type
Keystone docking

CONFEZ.
BOX 6 pz
IMBALLO
PACKAGE 120 pz



Tensione alimentazione In:
100-240V~ 50/60Hz
Tensione alimentazione Out:
5Vdc 2.1A
Input: 100-240V~ 50/60Hz
Output: 5Vdc 2.1A



ECL4081C WH

Alimentatore USB tipo C da incasso
Aggancio Keystone
USB charger C type
Keystone docking

CONFEZ.
BOX 6 pz
IMBALLO
PACKAGE 120 pz



Tensione alimentazione In:
100-240V~ 50/60Hz
Tensione alimentazione Out:
5Vdc 2.1A
Input: 100-240V~ 50/60Hz
Output: 5Vdc 2.1A



ECL4089 WH

Presca standard USB aggancio Keystone
USB standard socket - Keystone docking

CONFEZ.
BOX 6 pz
IMBALLO
PACKAGE 120 pz



ECL408301 WH

Adattatore Keystone
connettore telefonia/dati
Keystone adapter
telephone/data connector

CONFEZ.
BOX 32 pz
IMBALLO
PACKAGE 640 pz



PRESE TV E SAT TELEVISION AND SATELLITE SOCKETS

Specifiche tecniche a pag. 125
Technical features page 125



ECL2048 3

Resistenza terminale
di chiusura linea prese TV
impedenza 75 Ohm
Terminal closing TV socket line
impedance 75 Ohm

CONFEZ.
BOX 20 pz



ECL4048 1 WH

Presca coassiale TV
DIRETTA per impianti monoutenza
PASSANTE per impianti a cascata
TERMINATA con collegamento
all'art. ECL20483 per impianti a cascata

CONFEZ.
BOX 12 pz
IMBALLO
PACKAGE 240 pz



TV socket
DIRECT for single user system
PASSING for system with fall distribution
TERMINAL connected with art. ECL20483
for system with fall distribution

Connettore femmina D mm 9,5
Attenuazione di passaggio 0 dB
VHF-UHF (40-860MHz)



ECL4048 1MWH

Presca coassiale TV
DIRETTA per impianti monoutenza
PASSANTE per impianti a cascata
TERMINATA con collegamento
all'art. ECL20483 per impianti a cascata

CONFEZ.
BOX 12 pz
IMBALLO
PACKAGE 240 pz



TV socket
DIRECT for single user system
PASSING for system with fall distribution
TERMINAL connected with art. ECL20483
for system with fall distribution

Connettore maschio
Attenuazione di passaggio 0 dB
VHF-UHF (40-860MHz)



PRESE TV E SAT TELEVISION AND SATELLITE SOCKETS *Specifiche tecniche a pag. 125*
Technical features page 125



ECL4051 WH

Presse coassiale ULB diretta
Direct ULB socket



Connettore maschio (CEI EN 61169-2)
 Totalmente schermata
 per impianti tradizionali e satellitari
 Attenuazione 0 dB - 5-2400MHz - Classe A
Male connector (CEI EN 61169-2)
Totally shielded for TV and SAT systems
Signal attenuation 0 dB - 5-2400MHz - A class

CONF. BOX 12 pz
IMBALLO PACKAGE 240 pz



ECL4054 WH

Presse coassiale ULB passante
 Attenuazione 4 dB
Passing ULB socket
Signal attenuation 4 dB

CONF. BOX 12 pz
IMBALLO PACKAGE 240 pz

ECL4055 WH

Presse coassiale ULB passante
 Attenuazione 7 dB
Passing ULB socket
Signal attenuation 7 dB

CONF. BOX 12 pz
IMBALLO PACKAGE 240 pz

ECL4056 WH

Presse coassiale ULB passante
 Attenuazione 10 dB
Passing ULB socket
Signal attenuation 10 dB

CONF. BOX 12 pz
IMBALLO PACKAGE 240 pz



ECL4052 SATWH

Presse coassiale TV SAT diretta
Direct TV SAT socket



Connettore femmina (IEC 60169-24)
 Totalmente schermata
 per impianti tradizionali e satellitari
 Attenuazione 0 dB
 TV-SAT (5-2400MHz) - Classe A
Female connector (IEC 60169-24)
Totally shielded for TV and SAT systems
Signal attenuation 0 dB
TV-SAT (5-2400MHz) - A class

CONF. BOX 12 pz
IMBALLO PACKAGE 240 pz



ECL4057 SATWH

Presse coassiale TV SAT passante
Passing TV SAT socket



Connettore femmina (IEC 60169-24)
 Totalmente schermata
 per impianti tradizionali e satellitari
 Attenuazione 4 dB
 TV-SAT (5-2400MHz) - Classe A
Female connector (IEC 60169-24)
Totally shielded for TV and SAT systems
Signal attenuation 4 dB
TV-SAT (5-2400MHz) - A class

CONF. BOX 12 pz
IMBALLO PACKAGE 240 pz



ECL4058 FMSATWH

Presse 3 porte TV-FM-SAT diretta
Direct TV-FM-SAT triplex socket

CONF. BOX 6 pz
IMBALLO PACKAGE 120 pz



Connettore TV maschio (CEI EN 61169-2)
 Connettore RADIO femmina (CEI EN 61169-2)
 Connettore SAT tipo F femmina
 Totalmente schermata per impianti tradizionali e satellitari
 Attenuazione 1dB - 4-2400 MHz
Male TV connector (CEI EN 61169-2)
Female FM connector (CEI EN 61169-2)
Female F-type SAT connector
Totally shielded for TV and SAT systems
Signal attenuation 1dB - 4-2400 MHz



ECL4053 SATWH

Presse coassiale SAT tipo F
TV SAT socket F-type



Connettore femmina (IEC 60169-24)
 max 2400MHz
Female connector (IEC 60169-24)
 max 2400MHz

CONF. BOX 12 pz
IMBALLO PACKAGE 240 pz



ECL4100 WH

Presse DEMIX TV-SAT diretta
Direct DEMIX TV-SAT socket



Connettore maschio-femmina
 Totalmente schermata
 per impianti tradizionali e satellitari
 Attenuazione 0 dB
 5-2150MHz - Classe A
Male and female socket
Totally shielded for TV and SAT systems
Signal attenuation 0 dB
5-2150MHz - A class

CONF. BOX 12 pz
IMBALLO PACKAGE 240 pz



ECL4101 WH

Presse DEMIX TV-SAT passante
Passing DEMIX TV-SAT socket

CONF. BOX 12 pz
IMBALLO PACKAGE 240 pz



Connettore maschio-femmina
 Totalmente schermata
 per impianti tradizionali e satellitari
 Attenuazione 4 dB
 5-2150MHz - Classe A
Male and female socket
Totally shielded for TV and SAT systems
Signal attenuation 4 dB
5-2150MHz - A class



ECL4088 WH

Presse standard HDMI aggancio Keystone con 10 cm di cavo
HDMI standard socket - Keystone docking with 10 cm cable



CONF. BOX 6 pz
IMBALLO PACKAGE 120 pz

APPARECCHI DI COMANDO SPECIALI SPECIAL DEVICES



ECL4025 WH

Pulsante con portanome
Name holder push button

CONF. BOX 6 pz
IMBALLO PACKAGE 120 pz



ECL4061 WH

Interruttore unipolare con chiave
 Estrazione chiave in posizione ON e OFF
1 way single pole switch with key
Key extraction in ON and OFF position

CONF. BOX 12 pz
IMBALLO PACKAGE 240 pz



ECL4061 UNEWH

Interruttore unipolare con chiave unificata
 Estrazione chiave solo in OFF
1 way single pole switch with unified key
Key extraction only in OFF position

CONF. BOX 6 pz
IMBALLO PACKAGE 120 pz



ECL4061U WH

Interruttore unipolare con chiave unificata
 Estrazione chiave in posizione ON e OFF
1 way single pole switch with unified key
Key extraction in ON and OFF position

CONF. BOX 6 pz
IMBALLO PACKAGE 120 pz



ECL4065 WH

Interruttore automatico ad infrarosso passivo
Passive infra-red automatic switch

CONF. BOX 1 pz



230V~ C.o. ± 10% 50 Hz
 Relè SA/250V~ uscita a corrente limitata con resistenza per ZERO CROSSING di elevato valore
 Lampade incandescenza 800W
 Lampade fluorescenti 200W CFL6
 Regolazione temporizzazione:
 minimo circa 5 sec. - 12min.
 Regolazione luminosità: da circa 5 a circa 200 LUX
 Angolo di rilevamento: fino a 110° a 20°C
 Campo di rilevamento: circa 8mt a 20°C
 230V~ C.o. ± 10% 50 Hz
 Relè SA/250V~ output voltage limited to ZERO CROSSING
 Incandescent lamp 800W
 Fluorescent lamp 200W CFL6
 Delay time adjustable:
 min 5 sec. about 12min.
 Brightness control: from 5 to 200 LUX about
 Detection angle: until to 110° to 20°C
 Detection distance: 8mt about to 20°C

Specifiche tecniche a pag. 126
Technical features page 126

APPARECCHI DI COMANDO ELETTRONICI ELECTRONIC DEVICES



ECL4062L

Cronotermostato settimanale digitale 3 moduli da incasso alimentato a batterie predisposto con supporto di aggancio e 3 covers colorate
3 modules weekly digital thermostat batteries power supply with wall frame and 3 coloured covers included

CONFEZ. BOX 1 pz



Alimentazione 2 batterie 1,5V~
Scala di regolazione temperatura da 2° a 40 °C
Differenziale 0,25K
Power supply 2 batteries 1,5V~
Temperature adjustment range from 2° to 40 °C
Differential 0,25K

Specifiche tecniche a pag. 127
Technical features page 127



ECL4063L WH

Termostato ambiente elettronico 3 moduli da incasso alimentato a batterie predisposto con supporto di aggancio
3 modules electronic thermostat batteries power supply with wall frame and 3 coloured covers included

CONFEZ. BOX 1 pz



Alimentazione 3 batterie 1,5V~
Scala di regolazione temperatura da 5° a 30 °C
Power supply 3 batteries 1,5V~
Temperature adjustment range from 5° to 30 °C

Specifiche tecniche a pag. 127
Technical features page 127



ECL4026 WH

Interruttore a badge 3 moduli predisposto con supporto di aggancio
3 modules badge switch with wall frame included

CONFEZ. BOX 1 pz



Input 24Vdc - Output 3A 250V~
Tempo di cortesia programmabile da 10s a 30s
Illuminazione della tasca con led blu per individuazione al buio
Compatibile con tessere transponder utilizzate da sistemi di serratura elettronica per hotel:
CISA, SALTO, Vingcard/Assa Abloy, Dormakaba
Fornito con tessera transponder

Input 24Vdc - Output 3A 250V~
Programmable courtesy time from 10s to 30s
Blu led light in the card insertion slot for identification in the dark
Compatible with transponder cards used by electronic lock systems for hotel:
CISA, SALTO, Vingcard/Assa Abloy, Dormakaba
Transponder card supplied

Specifiche tecniche a pag. 128
Technical features page 128



ECL4026T

Tessera transponder Mifare
Mifare transponder card

CONFEZ. BOX 1 pz

Stampa opzionale
Immagine puramente indicativa
Optional print
Purely indicative image



Standard ISO/IEC 14443A/B
13,56 MHz (RFID frequency)
colore bianco
ISO/IEC 14443A/B standard
13,56 MHz (RFID frequency)
white color

Specifiche tecniche a pag. 128
Technical features page 128

Specifiche tecniche a pag. 128
Technical features page 128

Specifiche tecniche a pag. 129
Technical features page 129



ECL4026A

Alimentatore 230V~ per interruttore badge (ECL4026)
230V~ power supply for badge switch (ECL4026)

CONFEZ. BOX 1 pz



Specifiche tecniche a pag. 129, 130
Technical features page 129, 130



PER LAMPADINE A LED
LED LAMPS

ECL4705 WH

Variatore di luminosità universale con deviatore push-push per led dimmerabili e carichi resistivi/induttivi con punto luminoso rosso per individuazione al buio
Universal dimmerable led light and resistive/inductive dimmer with 2 way single pole switch. Push action. Red indicator light in the front side

CONFEZ. BOX 6 pz

IMBALLO PACKAGE 120 pz

Led dimmerabili/dimmerable led 4W-80W
Resistivi/Resistive 20W-150W
Induttivi/Inductive 20VA-100VA



ECL4701 WH

Variatore di luminosità con deviatore push-push per carichi resistivi con punto luminoso rosso per individuazione al buio
Resistive light dimmer with 2 way single pole switch. Push action. Red indicator light in the front side

CONFEZ. BOX 6 pz

IMBALLO PACKAGE 120 pz



100-500W 230V~



ECL4702 WH

Variatore di luminosità con deviatore push-push per carichi induttivi con punto luminoso rosso per individuazione al buio
Inductive light dimmer with 2 way single pole switch. Push action. Red indicator light in the front side

CONFEZ. BOX 6 pz

IMBALLO PACKAGE 120 pz



40-160 VA 230V~



ECL4703 WH

Variatore di luminosità rotativo per carichi resistivi con punto luminoso rosso per individuazione al buio
Resistive revolving light dimmer with 1 way single pole switch. Red indicator light in the front side

CONFEZ. BOX 6 pz

IMBALLO PACKAGE 120 pz



100-500W 230V~



ECL4704 WH

Variatore di luminosità rotativo per carichi induttivi con punto luminoso rosso per individuazione al buio
Inductive revolving light dimmer with 1 way single pole switch. Red indicator light in the front side

CONFEZ. BOX 6 pz

IMBALLO PACKAGE 120 pz



40-160 VA 230 V~

APPARECCHI DI SEGNALAZIONE ACUSTICA E LUMINOSA SOUND AND LIGHT SIGNALLING DEVICES



ECL4072 1WH 12V~ 50Hz 8VA max

Suoneria
Bell
Funzionamento intermittente 5/15:
l'emissione sonora può durare
fino a 5s max, seguita da
un periodo di riposo di 15s.

*Intermittent sound 5/15:
the sound emission can last up
to max 5 seconds, followed by
a period at rest of 15 seconds.*

CONF. BOX 12 pz
IMBALLO PACKAGE 240 pz



ECL4072 10WH 220V~ 50Hz 8VA max

Suoneria
Bell
Funzionamento intermittente 5/15:
l'emissione sonora può durare
fino a 5s max, seguita da
un periodo di riposo di 15s.

*Intermittent sound 5/15:
the sound emission can last up
to max 5 seconds, followed by
a period at rest of 15 seconds.*

CONF. BOX 12 pz
IMBALLO PACKAGE 240 pz



ECL4075 1WH 12V~ 50Hz 8VA max

Ronzatore
Buzzer
Funzionamento intermittente 5/15:
l'emissione sonora può durare
fino a 5s max, seguita da
un periodo di riposo di 15s.

*Intermittent sound 5/15:
the sound emission can last up
to max 5 seconds, followed by
a period at rest of 15 seconds.*

CONF. BOX 12 pz
IMBALLO PACKAGE 240 pz



ECL4075 10WH 220V~ 50Hz 8VA max

Ronzatore
Buzzer
Funzionamento intermittente 5/15:
l'emissione sonora può durare
fino a 5s max, seguita da
un periodo di riposo di 15s.

*Intermittent sound 5/15:
the sound emission can last up
to max 5 seconds, followed by
a period at rest of 15 seconds.*

CONF. BOX 12 pz
IMBALLO PACKAGE 240 pz



ECL4066

Diffusore notturno a LED 3 moduli predisposto con supporto di aggancio
compatibile con le placche MYLIFE® - MYLIFE Q® - NEW PRESTIGE®
3 modules LED night diffuser with wall frame included
compatible with MYLIFE® - MYLIFE Q® - NEW PRESTIGE® cover plates

CONF. BOX 1 pz
IMBALLO PACKAGE 20 pz



230V~ 50Hz
Lampada:
3 LEDS colore bianco
Intensità luminosa:
> 12.000 mcd @ 20mA
Temperatura di
funzionamento: 0° + 40°C
230V~ 50Hz
Bulb: 3 LEDS white colour
Brightness: > 12.000 mcd @ 20mA
Working temperature: 0° + 40°C



ECL40661 WH

Diffusore notturno a LED
1 modulo aggancio KEYSTONE
1 module LED night diffuser
KEYSTONE docking

CONF. BOX 6 pz
IMBALLO PACKAGE 30 pz



230V~ 50Hz
Lampada 1 LED colore bianco
Intensità luminosa:
> 1800 mcd @ 3.7mA
Funzioni: ON (SA) - AUTO (SE)
Temperatura di
funzionamento: -10° + 40°
230V~ 50Hz
Bulb: 1 LED WHITE COLOUR
Brightness: > 1800 mcd @ 3.7mA
Function: ON (SA) - AUTO (SE)
Working temperature: -10° + 40°



ECL4076

Segnalatore ottico/acustico per chiamate di emergenza
predisposto con supporto di aggancio e placca
compatibile con le placche MYLIFE® - MYLIFE Q® - NEW PRESTIGE®
Optical/acoustic indicator device for emergency calls
with wall frame and cover plate included
compatible with MYLIFE® - MYLIFE Q® - NEW PRESTIGE® cover plates

CONF. BOX 1 pz
IMBALLO PACKAGE 18 pz



Alimentazione: 12-24V~
tramite trasformatore di sicurezza
Consumo max: 2W
Segnalazione luminosa:
LED rosso alta luminosità
Segnalazione Acustica:
1 ronzatore Piezo 95dB ad 1 mt
Power supply: 12-24V~
through safety transformer
Max power consumption: 2W
Light signal: red LED
Sound signal: Buzzer Piezo 95dB 1mt far

Specifiche tecniche a pag. 131
Technical features page 131



ECL4077

Segnalatore ottico/acustico per chiamate di emergenza
predisposto con supporto di aggancio e placca - Funzionamento autonomo
compatibile con le placche MYLIFE® - MYLIFE Q® - NEW PRESTIGE®
Optical/acoustic indicator device for emergency calls
with wall frame and cover plate included - Independent operation
compatible with MYLIFE® - MYLIFE Q® - NEW PRESTIGE® cover plates

CONF. BOX 1 pz
IMBALLO PACKAGE 18 pz



Alimentazione: 12-24V~
tramite trasformatore di sicurezza
Consumo max: 2W
Segnalazione luminosa:
LED rosso alta luminosità
Segnalazione Acustica:
1 ronzatore Piezo 95dB ad 1 mt
Power supply: 12-24V~
through safety transformer
Max power consumption: 2W
Light signal: red LED
Sound signal: Buzzer Piezo 95dB 1mt far

Specifiche tecniche a pag. 132
Technical features page 132

COPRITASTI INTERCAMBIABILI 1 MODULO 1 MODULE INTERCHANGEABLE COVERS



ECL4080 WH

Falso polo
Blank cap

CONFEZ.
BOX 32 pz
IMBALLO
PACKAGE 640 pz



ECL4080 2WH

Falso polo con uscita Ø9 mm
Blank cap with Ø9 mm hole

CONFEZ.
BOX 32 pz
IMBALLO
PACKAGE 640 pz



ECL4090 3WH

Copritasto singolo
Key cover

CONFEZ.
BOX 50 pz
IMBALLO
PACKAGE 1000 pz



ECL4090 4WH

Copritasto singolo illuminabile
Lighttable key cover

CONFEZ.
BOX 50 pz
IMBALLO
PACKAGE 1000 pz



ECL4090 5WH

Copritasto singolo
per interruttore bipolare
Key cover for 1 way
double poles switch

CONFEZ.
BOX 50 pz
IMBALLO
PACKAGE 1000 pz



ECL4090 6WH

Copritasto singolo illuminabile
per interruttore bipolare
Lighttable key cover for 1 way
double poles switch

CONFEZ.
BOX 50 pz
IMBALLO
PACKAGE 1000 pz



ECL4090 7WH

Copritasto singolo
per pulsante generico
Key cover
for push button

CONFEZ.
BOX 50 pz
IMBALLO
PACKAGE 1000 pz



ECL4090 8WH

Copritasto singolo illuminabile
per pulsante generico
Lighttable key cover
for push button

CONFEZ.
BOX 50 pz
IMBALLO
PACKAGE 1000 pz



ECL4090 9WH

Copritasto
pulsante simbolo chiave
Key cover for push button
with key symbol

CONFEZ.
BOX 50 pz
IMBALLO
PACKAGE 1000 pz



ECL4090 10WH

Copritasto
pulsante simbolo luce
Key cover for push button
with lamp symbol

CONFEZ.
BOX 50 pz
IMBALLO
PACKAGE 1000 pz



ECL4090 11WH

Copritasto
pulsante simbolo campanello
Key cover for push button
with bell symbol

CONFEZ.
BOX 50 pz
IMBALLO
PACKAGE 1000 pz



ECL4090 12WH

Copritasto
pulsante simbolo infermiera
Key cover for push button
with nurse symbol

CONFEZ.
BOX 50 pz
IMBALLO
PACKAGE 1000 pz



COPRITASTI INTERCAMBIABILI 2 MODULI 2 MODULES INTERCHANGEABLE COVERS



ECL4090 13WH

Copritasto doppio
Double key cover

CONFEZ.
BOX 6 pz
IMBALLO
PACKAGE 120 pz



ECL4090 14WH

Copritasto doppio illuminabile
Lighttable double key cover

CONFEZ.
BOX 6 pz
IMBALLO
PACKAGE 120 pz



ECL4090 15WH

Copritasto doppio bipolare
Double key cover
for 1 way double poles switch

CONFEZ.
BOX 6 pz
IMBALLO
PACKAGE 120 pz



ECL4090 16WH

Copritasto doppio bipolare illuminabile
Lighttable double key cover
for 1 way double poles switch

CONFEZ.
BOX 6 pz
IMBALLO
PACKAGE 120 pz



COPRITASTI INTERCAMBIABILI 3 MODULI 3 MODULES INTERCHANGEABLE COVERS



ECL4090 17WH

Copritasto triplo
Triple key cover

CONFEZ.
BOX 4 pz
IMBALLO
PACKAGE 80 pz



ECL4090 18WH

Copritasto triplo illuminabile
Lightable triple key cover

CONFEZ.
BOX 4 pz
IMBALLO
PACKAGE 80 pz



ECL4090 19WH

Copritasto triplo bipolare
*Triple key cover
for 1 way double poles switch*

CONFEZ.
BOX 4 pz
IMBALLO
PACKAGE 80 pz



ECL4090 20WH

Copritasto triplo bipolare illuminabile
*Lightable triple key cover
for 1 way double poles switch*

CONFEZ.
BOX 4 pz
IMBALLO
PACKAGE 80 pz



SUPPORTI A PARETE MYLIFE® MYLIFE® WALL FRAMES



ECL4603F

Supporto 3 moduli con viti
aggancio frutti frontale
*3 modules frame with screws
front docking*

CONFEZ.
BOX 100 pz



ECL4604F

Supporto 4 moduli con viti - aggancio frutti frontale
4 modules frame with screws - front docking

CONFEZ.
BOX 20 pz
IMBALLO
PACKAGE 160 pz



ECL4607F

Supporto 7 moduli con viti - aggancio frutti frontale
7 modules frame with screws - front docking

CONFEZ.
BOX 10 pz
IMBALLO
PACKAGE 80 pz



SUPPORTI PER PROFILATI O PANNELLI PROFILES OR PANELS FRAMES



ECL4609AC

Supporto placca con viti per installazione su profilati o pannelli
1 modulo - Completo di scatola di da incasso dedicata
*Cover plate frame with screws for installation on profiles or panels
1 module - Completed with dedicated wall box*

CONFEZ.
BOX 1 pz
IMBALLO
PACKAGE 25 pz

Colore alluminio chiaro
Light aluminium colour



ECL4609WH

Supporto placca con viti per installazione su profilati o pannelli
1 modulo - Completo di scatola di da incasso dedicata
*Cover plate frame with screws for installation on profiles or panels
1 module - Completed with dedicated wall box*

CONFEZ.
BOX 1 pz
IMBALLO
PACKAGE 25 pz

Colore bianco
White colour



ECL4609N

Supporto placca con viti per installazione su profilati o pannelli
1 modulo - Completo di scatola di da incasso dedicata
*Cover plate frame with screws for installation on profiles or panels
1 module - Completed with dedicated wall box*

CONFEZ.
BOX 1 pz
IMBALLO
PACKAGE 25 pz

Colore nero
Black colour



ADATTATORI E SUPPORTI SPECIALI ADAPTERS AND SPECIAL WALL FRAMES



ECL4608

Adattatore per: 2 moduli Serie myLife
3 moduli Barra Din
*Adapter for: 2 modules myLife Series
3 modules Din Bar*

CONFEZ.
BOX 40 pz



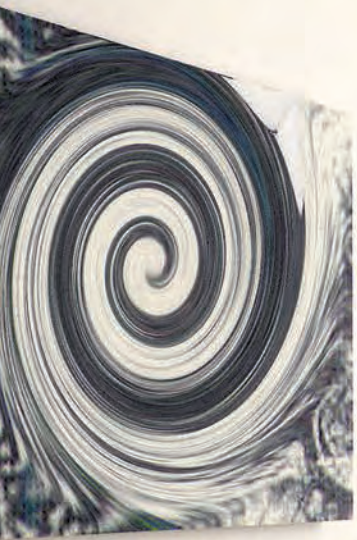

my life®

Apparecchi modulari Finitura Grigia

MYLIFE® dialoga con i sensi. Stimola le sensazioni tattili e visive, riporta alla mente profumi e risveglia il buon gusto, ascolta le aspirazioni e parla del tuo mondo, degli spazi in cui vivi sottolineando la tua personalità.

La linea MYLIFE® grigia dà quel tocco di raffinatezza in armonia con tutti gli stili e gli elementi d'arredo: si fonde con gli spazi minimalisti, accompagna elegantemente le preziosità classiche, esalta i contesti etnici o di tendenza.

Modular devices Grey finishing

MYLIFE® is in an harmonious dialogue with your senses. Shakes your tactile feelings, raises your pleasant taste, listens your ambitions and speaks about your life, your places underscoring your personality.

MYLIFE® grey gives a very good taste in perfect balance with several different elements of furniture: melts itself with minimal spaces, leads finely classic preciousity, and exalts ethnics places.



APPARECCHI DI COMANDO BASE BASIC SWITCHING DEVICES



ECL4000

Interruttore unipolare
1 way single pole switch

CONFEZ. BOX 12 pz
IMBALLO PACKAGE 240 pz



ECL4003

Deviatore unipolare
2 way single pole switch

CONFEZ. BOX 12 pz
IMBALLO PACKAGE 240 pz



ECL4006

Invertitore unipolare
Intermediate single pole switch

CONFEZ. BOX 12 pz
IMBALLO PACKAGE 240 pz



ECL4009

Interruttore bipolare
1 way double pole switch

CONFEZ. BOX 12 pz
IMBALLO PACKAGE 240 pz



ECL4021

Pulsante unipolare generico
Push button

CONFEZ. BOX 12 pz
IMBALLO PACKAGE 240 pz



ECL4021 NC

Pulsante unipolare
normalmente chiuso
Normally closed
push button

CONFEZ. BOX 12 pz
IMBALLO PACKAGE 240 pz



ECL4020

Commutatore 1P
con OFF centrale (1-0-2)
2 way 1P switch
with central OFF position (1-0-2)

CONFEZ. BOX 12 pz
IMBALLO PACKAGE 240 pz



16AX 250V~
Specifiche tecniche a pag. 119
Technical features page 119



ECL4022

Doppio pulsante interbloccato
(1P/NO)+(1P/NO)
Interlocked twin single pole push button
(1P/NO)+(1P/NO)

CONFEZ. BOX 12 pz
IMBALLO PACKAGE 240 pz



10A 250V~
Specifiche tecniche a pag. 119
Technical features page 119



ECL4023

Doppio pulsante
(1P/NO)+(1P/NO)
Twin single pole push button
(1P/NO)+(1P/NO)

CONFEZ. BOX 12 pz
IMBALLO PACKAGE 240 pz



10A 250V~
Specifiche tecniche a pag. 119
Technical features page 119



ECL4024

Pulsante unipolare a tirante
Push button with cord

CONFEZ. BOX 6 pz
IMBALLO PACKAGE 120 pz



Lunghezza cordino 1,5 m
Cord length 1,5 m
16A 250V~ 1P/NO

APPARECCHI DI COMANDO ILLUMINABILI LIGHTABLE SWITCHING DEVICES

Specifiche tecniche a pag. 119
Technical features page 119



ECL4012

Interruttore unipolare illuminabile
(lampada spia non inclusa)
Lightable 1 way single pole switch
(indicator lamp not supplied)

CONFEZ. BOX 12 pz
IMBALLO PACKAGE 240 pz



16AX 250V~



ECL4013

Deviatore unipolare illuminabile
(lampada spia non inclusa)
Lightable 2 way single pole switch
(indicator lamp not supplied)

CONFEZ. BOX 12 pz
IMBALLO PACKAGE 240 pz



16AX 250V~



ECL4016

Invertitore unipolare illuminabile
(lampada spia non inclusa)
Lightable intermediate
single pole switch
(indicator lamp not supplied)

CONFEZ. BOX 12 pz
IMBALLO PACKAGE 240 pz



16AX 250V~



ECL4015

Interruttore bipolare illuminabile
(lampada spia non inclusa)
Lightable 1 way double pole switch
(indicator lamp not supplied)

CONFEZ. BOX 12 pz
IMBALLO PACKAGE 240 pz



16AX 250V~



ECL4018

Pulsante unipolare illuminabile
(lampada spia non inclusa)
Lightable push button
(indicator lamp not supplied)

CONFEZ. BOX 12 pz
IMBALLO PACKAGE 240 pz



16A 250V~ 1P/NO



ECL4000 LN

Lampada spia cavo mm 100
Indicator neon lamp
with 100 mm cable

CONFEZ. BOX 50 pz
IMBALLO PACKAGE 1000 pz



Colore neon: blu
Neon color: blue

230V~ 0,5W max 2mA max



ECL4000 LD

Lampada spia a LED cavo mm 100
Indicator LED lamp
with 100 mm cable

CONFEZ. BOX 50 pz
IMBALLO PACKAGE 1000 pz



Colore LED: blu
LED color: blue

230V~ 0,125W 0,5mA max



ECL4000 LD12

Lampada spia a LED cavo mm 100
Indicator LED lamp
with 100 mm cable

CONFEZ. BOX 50 pz
IMBALLO PACKAGE 1000 pz



Colore LED: blu
LED color: blue

12/24V~ 0,025W max 1mA max

PRESE DI CORRENTE OUTLET SOCKETS



ECL4039

Presà italiana con sicurezza
Italian shuttered socket

CONF. BOX 12 pz
IMBALLO PACKAGE 240 pz

CE
10A 250V~
2P + ⊕
Standard P11



ECL4045

Presà italiana bivalente con sicurezza
Italian double shuttered socket

CONF. BOX 12 pz
IMBALLO PACKAGE 240 pz

CE
10/16A 250V~
2P + ⊕
Standard P17/P11



ECL4046

Presà italiana con sicurezza
2 moduli
*Italian shuttered socket
2 modules*

CONF. BOX 6 pz
IMBALLO PACKAGE 120 pz

CE
16A 250V~
2P + ⊕ centrale/central
Standard P30



ECL4050

Presà italiana/tedesca trivalente con sicurezza
2 moduli
*Italian/German triple shuttered socket
2 modules*

CONF. BOX 6 pz
IMBALLO PACKAGE 120 pz

CE
10/16A 250V~
2P + ⊕ centrale/central
Standard P40

PRESE STANDARD INTERNAZIONALI INTERNATIONAL STANDARD SOCKETS



ECL4037

Presà americana
American socket

CONF. BOX 12 pz
IMBALLO PACKAGE 240 pz

CE
15A 127V~
2P + ⊕



ECL4038

Presà euroamericana
Euroamerican socket

CONF. BOX 12 pz
IMBALLO PACKAGE 240 pz

CE
16A 127/250V~
2P



ECL4049

Presà euroamericana con sicurezza
Euroamerican shuttered socket

CONF. BOX 12 pz
IMBALLO PACKAGE 240 pz

CE
16A 127/250V~
2P



ECL4040

Presà euroamericana
Euroamerican socket

CONF. BOX 12 pz
IMBALLO PACKAGE 240 pz

CE
16A 127/250V~
2P + ⊕



ECL4042

Presà euroamericana duplex - 3 moduli
Euroamerican duplex socket - 3 modules

CONF. BOX 4 pz
IMBALLO PACKAGE 80 pz

CE
16A 127/250V~
2P + ⊕



ECL4044

Presà francese con sicurezza
2 moduli
*French shuttered socket
2 modules*

CONF. BOX 6 pz
IMBALLO PACKAGE 120 pz

CE
16A 250V~
2P + ⊕



ECL4047

Presà tedesca con sicurezza
2 moduli
*German shuttered socket
2 modules*

CONF. BOX 6 pz
IMBALLO PACKAGE 120 pz

CE
16A 250V~
2P + ⊕ centrale/central
Standard P30



ECL4041

Presà inglese con sicurezza
2 moduli
*English shuttered socket
2 modules*

CONF. BOX 6 pz
IMBALLO PACKAGE 120 pz

CE
13A 250V~
2P + ⊕

DISPOSITIVI DI SICUREZZA SAFETY DEVICES

Specifiche tecniche a pag. 120, 121
Technical features page 120, 121



ECL4043

Limitatore di sovratensione
Voltage surge limiter

CONF. BOX 6 pz
IMBALLO PACKAGE 120 pz

CE
250 V~ Classe II
Tensione massima di protezione 1kV
Potere di scarica 4,5 kA (8/20 μs)
Energia dissipabile 72 J (2 ms)
250 V~ II Class
Max voltage of protection 1kV
Discharge power 4,5 kA (8/20 μs)
Dissipate energy 72J (2ms)



ECL4400

Interruttore automatico magnetotermico C10 - 1 modulo
Thermal-magnetic automatic switch C10 - 1 module

CONF. BOX 6 pz
IMBALLO PACKAGE 120 pz

CE
1P + N
Potere di interruzione: 3kA
Breaking power: 3kA



ECL4401

Interruttore automatico magnetotermico C16 - 1 modulo
Thermal-magnetic automatic switch C16 - 1 module

CONF. BOX 6 pz
IMBALLO PACKAGE 120 pz

CE
1P + N
Potere di interruzione: 3kA
Breaking power: 3kA



ECL4402

Interruttore automatico magnetotermico differenziale C10 - 2 moduli
Differential thermal-magnetic automatic switch C10 - 2 modules

CONF. BOX 3 pz
IMBALLO PACKAGE 60 pz

CE
1P + N - 10mA
Potere di interruzione: 3kA
Breaking power: 3kA



ECL4403

Interruttore automatico magnetotermico differenziale C16 - 2 moduli
Differential thermal-magnetic automatic switch C16 - 2 modules

CONF. BOX 3 pz
IMBALLO PACKAGE 60 pz

CE
1P + N - 10mA
Potere di interruzione: 3kA
Breaking power: 3kA

PRESE TELEFONICHE E TRASMISSIONE DATI TELEPHONE AND DATA SOCKETS

Specifiche tecniche a pag. 122, 123, 124
Technical features page 122, 123, 124



ECL4084

Presca telefonica RJ11 plug 6/4
RJ11 telephone socket

CONFEZ. BOX 12 pz
IMBALLO PACKAGE 240 pz



ECL4082

Presca telefonica RJ11 plug 6/4
RJ12 plug 6/6 autocrimpante
Self-crimping telephone socket
RJ11 plug 6/4 RJ12 plug 6/6

CONFEZ. BOX 6 pz
IMBALLO PACKAGE 120 pz



ECL4083

Presca RJ45 cat 5e UTP
non schermata autocrimpante
Self-crimping RJ45 socket cat 5e UTP

CONFEZ. BOX 6 pz
IMBALLO PACKAGE 120 pz



ECL4085

Presca RJ45 cat 5e FTP
schermata autocrimpante
Self-crimping RJ45 socket cat 5e FTP

CONFEZ. BOX 6 pz
IMBALLO PACKAGE 120 pz



ECL4087

Presca RJ45 cat 6 UTP
non schermata autocrimpante
Self-crimping RJ45 socket cat 6 UTP

CONFEZ. BOX 6 pz
IMBALLO PACKAGE 120 pz



ECL4086

Presca RJ45 cat 6 FTP
schermata autocrimpante
Self-crimping RJ45 socket cat 6 FTP

CONFEZ. BOX 6 pz
IMBALLO PACKAGE 120 pz



ECL4081

Alimentatore USB tipo A da incasso
Aggancio Keystone
USB charger A type
Keystone docking

CONFEZ. BOX 6 pz
IMBALLO PACKAGE 120 pz



Tensione alimentazione In: 100-240V~ 50/60Hz
Tensione alimentazione Out: 5Vdc 2.1A
Input: 100-240V~ 50/60Hz
Output: 5Vdc 2.1A



ECL4081C

Alimentatore USB tipo C da incasso
Aggancio Keystone
USB charger C type
Keystone docking

CONFEZ. BOX 6 pz
IMBALLO PACKAGE 120 pz



Tensione alimentazione In: 100-240V~ 50/60Hz
Tensione alimentazione Out: 5Vdc 2.1A
Input: 100-240V~ 50/60Hz
Output: 5Vdc 2.1A



ECL4089

Presca standard USB aggancio Keystone
USB standard socket - Keystone docking

CONFEZ. BOX 6 pz
IMBALLO PACKAGE 120 pz



ECL408301

Adattatore Keystone
connettore telefonia/dati
Keystone adapter
telephone/data connector

CONFEZ. BOX 32 pz
IMBALLO PACKAGE 640 pz



PRESE TV E SAT TELEVISION AND SATELLITE SOCKETS

Specifiche tecniche a pag. 125
Technical features page 125



ECL2048 3

Resistenza terminale
di chiusura linea prese TV
impedenza 75 Ohm
Terminal closing TV socket line
impedance 75 Ohm

CONFEZ. BOX 20 pz



ECL4048 1

Presca coassiale TV
DIRETTA per impianti monoutenza
PASSANTE per impianti a cascata
TERMINATA con collegamento
all'art. ECL20483 per impianti a cascata

CONFEZ. BOX 12 pz
IMBALLO PACKAGE 240 pz



TV socket
DIRECT for single user system
PASSING for system with fall distribution
TERMINAL connected with art. ECL20483
for system with fall distribution

Connettore femmina D mm 9,5
Attenuazione di passaggio 0 dB
VHF-UHF (40-860MHz)



ECL4048 1M

Presca coassiale TV
DIRETTA per impianti monoutenza
PASSANTE per impianti a cascata
TERMINATA con collegamento
all'art. ECL20483 per impianti a cascata

CONFEZ. BOX 12 pz
IMBALLO PACKAGE 240 pz



TV socket
DIRECT for single user system
PASSING for system with fall distribution
TERMINAL connected with art. ECL20483
for system with fall distribution

Connettore maschio
Attenuazione di passaggio 0 dB
VHF-UHF (40-860MHz)



PRESE TV E SAT TELEVISION AND SATELLITE SOCKETS Specifiche tecniche a pag. 125
Technical features page 125



ECL4051

Presse coassiale ULB diretta
Direct ULB socket

CONFEZ.
BOX 12 pz
IMBALLO
PACKAGE 240 pz



Connettore maschio (CEI EN 61169-2)
Totalmente schermata
per impianti tradizionali e satellitari
Attenuazione 0 dB - 5-2400MHz - Classe A
*Male connector (CEI EN 61169-2)
Totally shielded for TV and SAT systems
Signal attenuation 0 dB - 5-2400MHz - A class*



ECL4054

Presse coassiale ULB passante
Attenuazione 4 dB
*Passing ULB socket
Signal attenuation 4 dB*

CONFEZ.
BOX 12 pz
IMBALLO
PACKAGE 240 pz



ECL4055

Presse coassiale ULB passante
Attenuazione 7 dB
*Passing ULB socket
Signal attenuation 7 dB*

Totalmente schermata per impianti tradizionali e satellitari - 5-2400MHz - Classe A
Totally shielded for TV and SAT systems - 5-2400MHz - A class

ECL4056

Presse coassiale ULB passante
Attenuazione 10 dB
*Passing ULB socket
Signal attenuation 10 dB*



Connettore maschio (CEI EN 61169-2)
Totalmente schermata per impianti tradizionali e satellitari - 5-2400MHz - Classe A
*Male connector (CEI EN 61169-2)
Totally shielded for TV and SAT systems - 5-2400MHz - A class*



ECL4052 SAT

Presse coassiale TV SAT diretta
Direct TV SAT socket

CONFEZ.
BOX 12 pz
IMBALLO
PACKAGE 240 pz



Connettore femmina (IEC 60169-24)
Totalmente schermata
per impianti tradizionali e satellitari
Attenuazione 0 dB
TV-SAT (5-2400MHz) - Classe A
*Female connector (IEC 60169-24)
Totally shielded for TV and SAT systems
Signal attenuation 0 dB
TV-SAT (5-2400MHz) - A class*



ECL4057 SAT

Presse coassiale TV SAT passante
Passing TV SAT socket

CONFEZ.
BOX 12 pz
IMBALLO
PACKAGE 240 pz



Connettore femmina (IEC 60169-24)
Totalmente schermata
per impianti tradizionali e satellitari
Attenuazione 4 dB
TV-SAT (5-2400MHz) - Classe A
*Female connector (IEC 60169-24)
Totally shielded for TV and SAT systems
Signal attenuation 4 dB
TV-SAT (5-2400MHz) - A class*



ECL4058 FMSAT

Presse 3 porte TV-FM-SAT diretta
Direct TV-FM-SAT triplex socket

CONFEZ.
BOX 6 pz
IMBALLO
PACKAGE 120 pz



Connettore TV maschio (CEI EN 61169-2)
Connettore RADIO femmina (CEI EN 61169-2)
Connettore SAT tipo F femmina
Totalmente schermata per impianti tradizionali e satellitari
Attenuazione 1dB - 4-2400 MHz



*Male TV connector (CEI EN 61169-2)
Female FM connector (CEI EN 61169-2)
Female F-type SAT connector
Totally shielded for TV and SAT systems
Signal attenuation 1dB - 4-2400 MHz*



ECL4053 SAT

Presse coassiale SAT tipo F
TV SAT socket F-type

CONFEZ.
BOX 12 pz
IMBALLO
PACKAGE 240 pz



Connettore femmina (IEC 60169-24)
max 2400MHz
*Female connector (IEC 60169-24)
max 2400MHz*



ECL4100

Presse DEMIX TV-SAT diretta
Direct DEMIX TV-SAT socket

CONFEZ.
BOX 12 pz
IMBALLO
PACKAGE 240 pz



Connettore maschio-femmina
Totalmente schermata
per impianti tradizionali e satellitari
Attenuazione 0 dB
5-2150MHz - Classe A
*Male and female socket
Totally shielded for TV and SAT systems
Signal attenuation 0 dB
5-2150MHz - A class*



ECL4101

Presse DEMIX TV-SAT passante
Passing DEMIX TV-SAT socket

CONFEZ.
BOX 12 pz
IMBALLO
PACKAGE 240 pz



Connettore maschio-femmina
Totalmente schermata
per impianti tradizionali e satellitari
Attenuazione 4 dB
5-2150MHz - Classe A
*Male and female socket
Totally shielded for TV and SAT systems
Signal attenuation 4 dB
5-2150MHz - A class*



ECL4088

Presse standard HDMI aggancio Keystone
con 10 cm di cavo
*HDMI standard socket - Keystone docking
with 10 cm cable*

CONFEZ.
BOX 6 pz
IMBALLO
PACKAGE 120 pz



APPARECCHI DI COMANDO SPECIALI SPECIAL DEVICES



ECL4025

Pulsante con portanome
Name holder push button

CONFEZ.
BOX 6 pz
IMBALLO
PACKAGE 120 pz



ECL4061

Interruttore unipolare con chiave
Estrazione chiave in posizione ON e OFF
*1 way single pole switch with key
Key extraction in ON and OFF position*

CONFEZ.
BOX 12 pz
IMBALLO
PACKAGE 240 pz



ECL4061 UNE

Interruttore unipolare con chiave unificata
Estrazione chiave solo in OFF
*1 way single pole switch with unified key
Key extraction only in OFF position*

CONFEZ.
BOX 6 pz
IMBALLO
PACKAGE 120 pz



ECL4061U

Interruttore unipolare con chiave unificata
Estrazione chiave in posizione ON e OFF
*1 way single pole switch with unified key
Key extraction in ON and OFF position*

CONFEZ.
BOX 6 pz
IMBALLO
PACKAGE 120 pz



ECL4065

Interruttore automatico ad infrarosso passivo
Passive infra-red automatic switch

CONFEZ.
BOX 1 pz



230V~ C.o. ± 10% 50 Hz
Relè 5A/250V~ uscita a corrente limitata con resistenza per ZERO CROSSING di elevato valore
Lampade incandescenza 800W
Lampade fluorescenti 200W CFL6
Regolazione temporizzazione:
minimo circa 5 sec. - 12min.
Regolazione luminosità: da circa 5 a circa 200 LUX
Angolo di rilevamento: fino a 110° a 20°C
Campo di rilevamento: circa 8mt a 20°C
230V~ C.o. ± 10% 50 Hz
Relè 5A/250V~ output voltage limited to ZERO CROSSING
Incandescent lamp 800W
Fluorescent lamp 200W CFL6
Delay time adjustable:
min 5 sec. about 12min.
Brightness control: from 5 to 200 LUX about
Detection angle: until to 110° to 20°C
Detection distance: 8mt about to 20°C

**Specifiche tecniche a pag. 126
Technical features page 126**

APPARECCHI DI COMANDO ELETTRONICI ELECTRONIC DEVICES



ECL4062L

Cronotermostato settimanale digitale 3 moduli da incasso alimentato a batterie predisposto con supporto di aggancio e 3 covers colorate
3 modules weekly digital thermostat batteries power supply with wall frame and 3 coloured covers included

CONFEZ. BOX 1 pz



Alimentazione 2 batterie 1,5V~
Scala di regolazione temperatura da 2° a 40 °C
Differenziale 0,25K
Power supply 2 batteries 1,5V~
Temperature adjustment range from 2° to 40 °C
Differential 0,25K

Specifiche tecniche a pag. 127
Technical features page 127



ECL4063L

Termostato ambiente elettronico 3 moduli da incasso alimentato a batterie predisposto con supporto di aggancio
3 modules electronic thermostat batteries power supply with wall frame and 3 coloured covers included

CONFEZ. BOX 1 pz



Alimentazione 3 batterie 1,5V~
Scala di regolazione temperatura da 5° a 30 °C
Power supply 3 batteries 1,5V~
Temperature adjustment range from 5° to 30 °C

Specifiche tecniche a pag. 127
Technical features page 127



ECL4026

Interruttore a badge 3 moduli predisposto con supporto di aggancio
3 modules badge switch with wall frame included

CONFEZ. BOX 1 pz



Input 24Vdc - Output 3A 250V~
Tempo di cortesia programmabile da 10s a 30s
Illuminazione della tasca con led blu per individuazione al buio
Compatibile con tessere transponder utilizzate da sistemi di serratura elettronica per hotel:
CISA, SALTO, Vingcard/Assa Abloy, Dormakaba
Fornito con tessera transponder

Input 24Vdc - Output 3A 250V~
Programmable courtesy time from 10s to 30s
Blu led light in the card insertion slot for identification in the dark
Compatible with transponder cards used by electronic lock systems for hotel:
CISA, SALTO, Vingcard/Assa Abloy, Dormakaba
Transponder card supplied

Specifiche tecniche a pag. 128
Technical features page 128



ECL4026T

Tessera transponder Mifare
Mifare transponder card

CONFEZ. BOX 1 pz

Stampa opzionale
Immagine puramente indicativa
Optional print
Purely indicative image



Standard ISO/IEC 14443A/B
13,56 MHz (RFID frequency)
colore bianco
ISO/IEC 14443A/B standard
13,56 MHz (RFID frequency)
white color

Specifiche tecniche a pag. 128
Technical features page 128

Specifiche tecniche a pag. 128
Technical features page 128

Specifiche tecniche a pag. 129
Technical features page 129



ECL4026A

Alimentatore 230V~ per interruttore badge (ECL4026)
230V~ power supply for badge switch (ECL4026)

CONFEZ. BOX 1 pz



PER LAMPADINE A LED
LED LAMPS

ECL4705

Variatore di luminosità universale con deviatore push-push per led dimmerabili e carichi resistivi/induttivi con punto luminoso rosso per individuazione al buio
Universal dimmerable led light and resistive/inductive dimmer with 2 way single pole switch. Push action. Red indicator light in the front side

CONFEZ. BOX 6 pz

IMBALLO PACKAGE 120 pz

Led dimmerabili/dimmerable led 4W-80W
Resistivi/Resistive 20W-150W
Induttivi/Inductive 20VA-100VA



Specifiche tecniche a pag. 129, 130
Technical features page 129, 130



ECL4701

Variatore di luminosità con deviatore push-push per carichi resistivi con punto luminoso rosso per individuazione al buio
Resistive light dimmer with 2 way single pole switch. Push action. Red indicator light in the front side

CONFEZ. BOX 6 pz

IMBALLO PACKAGE 120 pz



100-500W 230V~



ECL4702

Variatore di luminosità con deviatore push-push per carichi induttivi con punto luminoso rosso per individuazione al buio
Inductive light dimmer with 2 way single pole switch. Push action. Red indicator light in the front side

CONFEZ. BOX 6 pz

IMBALLO PACKAGE 120 pz



40-160 VA 230V~



ECL4703

Variatore di luminosità rotativo per carichi resistivi con punto luminoso rosso per individuazione al buio
Resistive revolving light dimmer with 1 way single pole switch. Red indicator light in the front side

CONFEZ. BOX 6 pz

IMBALLO PACKAGE 120 pz



100-500W 230V~



ECL4704

Variatore di luminosità rotativo per carichi induttivi con punto luminoso rosso per individuazione al buio
Inductive revolving light dimmer with 1 way single pole switch. Red indicator light in the front side

CONFEZ. BOX 6 pz

IMBALLO PACKAGE 120 pz



40-160 VA 230 V~

APPARECCHI DI SEGNALAZIONE ACUSTICA E LUMINOSA SOUND AND LIGHT SIGNALLING DEVICES



ECL4072 1

12V~ 50Hz 8VA max



Suoneria
Bell
Funzionamento intermittente 5/15:
l'emissione sonora può durare
fino a 5s max, seguita da
un periodo di riposo di 15s.

*Intermittent sound 5/15:
the sound emission can last up
to max 5 seconds, followed by
a period at rest of 15 seconds.*

CONFEZ.
BOX 12 pz
IMBALLO
PACKAGE 240 pz



ECL4072 10

220V~ 50Hz 8VA max



Suoneria
Bell
Funzionamento intermittente 5/15:
l'emissione sonora può durare
fino a 5s max, seguita da
un periodo di riposo di 15s.

*Intermittent sound 5/15:
the sound emission can last up
to max 5 seconds, followed by
a period at rest of 15 seconds.*

CONFEZ.
BOX 12 pz
IMBALLO
PACKAGE 240 pz



ECL4075 1

12V~ 50Hz 8VA max



Ronzatore
Buzzer
Funzionamento intermittente 5/15:
l'emissione sonora può durare
fino a 5s max, seguita da
un periodo di riposo di 15s.

*Intermittent sound 5/15:
the sound emission can last up
to max 5 seconds, followed by
a period at rest of 15 seconds.*

CONFEZ.
BOX 12 pz
IMBALLO
PACKAGE 240 pz



ECL4075 10

220V~ 50Hz 8VA max



Ronzatore
Buzzer
Funzionamento intermittente 5/15:
l'emissione sonora può durare
fino a 5s max, seguita da
un periodo di riposo di 15s.

*Intermittent sound 5/15:
the sound emission can last up
to max 5 seconds, followed by
a period at rest of 15 seconds.*

CONFEZ.
BOX 12 pz
IMBALLO
PACKAGE 240 pz



ECL4066

Diffusore notturno a LED 3 moduli predisposto con supporto di aggancio
compatibile con le placche MYLIFE® - MYLIFE Q® - NEW PRESTIGE®
3 modules LED night diffuser with wall frame included
compatible with MYLIFE® - MYLIFE Q® - NEW PRESTIGE® cover plates

CONFEZ.
BOX 1 pz
IMBALLO
PACKAGE 20 pz

230V~ 50Hz
Lampada:
3 LEDS colore bianco
Intensità luminosa:
> 12.000 mcd @ 20mA
Temperatura di
funzionamento: 0° + 40°C
230V~ 50Hz
Bulb: 3 LEDS white colour
Brightness: > 12.000 mcd @ 20mA
Working temperature: 0° + 40°C



ECL40661

Diffusore notturno a LED
1 modulo aggancio KEYSTONE
1 module LED night diffuser
KEYSTONE docking

CONFEZ.
BOX 6 pz
IMBALLO
PACKAGE 30 pz



230V~ 50Hz
Lampada 1 LED colore bianco
Intensità luminosa:
> 1800 mcd @ 3.7mA
Funzioni: ON (SA) - AUTO (SE)
Temperatura di
funzionamento: -10° + 40°
230V~ 50Hz
Bulb: 1 LED WHITE COLOUR
Brightness: > 1800 mcd @ 3.7mA
Function: ON (SA) - AUTO (SE)
Working temperature: -10° + 40°



ECL4076

Segnalatore ottico/acustico per chiamate di emergenza
predisposto con supporto di aggancio e placca
compatibile con le placche MYLIFE® - MYLIFE Q® - NEW PRESTIGE®
Optical/acoustic indicator device for emergency calls
with wall frame and cover plate included
compatible with MYLIFE® - MYLIFE Q® - NEW PRESTIGE® cover plates

CONFEZ.
BOX 1 pz
IMBALLO
PACKAGE 18 pz

Alimentazione: 12-24V~
tramite trasformatore di sicurezza
Consumo max: 2W
Segnalazione luminosa:
LED rosso alta luminosità
Segnalazione Acustica:
1 ronzatore Piezo 95dB ad 1 mt
Power supply: 12-24V~
through safety transformer
Max power consumption: 2W
Light signal: red LED
Sound signal: Buzzer Piezo 95dB 1mt far
Specifiche tecniche a pag. 131
Technical features page 131



ECL4077

Segnalatore ottico/acustico per chiamate di emergenza
predisposto con supporto di aggancio e placca - Funzionamento autonomo
compatibile con le placche MYLIFE® - MYLIFE Q® - NEW PRESTIGE®
Optical/acoustic indicator device for emergency calls
with wall frame and cover plate included - Independent operation
compatible with MYLIFE® - MYLIFE Q® - NEW PRESTIGE® cover plates

CONFEZ.
BOX 1 pz
IMBALLO
PACKAGE 18 pz

Alimentazione: 12-24V~
tramite trasformatore di sicurezza
Consumo max: 2W
Segnalazione luminosa:
LED rosso alta luminosità
Segnalazione Acustica:
1 ronzatore Piezo 95dB ad 1 mt
Power supply: 12-24V~
through safety transformer
Max power consumption: 2W
Light signal: red LED
Sound signal: Buzzer Piezo 95dB 1mt far
Specifiche tecniche a pag. 132
Technical features page 132

COPRITASTI INTERCAMBIABILI 1 MODULO 1 MODULE INTERCHANGEABLE COVERS



ECL4080

Falso polo
Blank cap

CONFEZ.
BOX 32 pz
IMBALLO
PACKAGE 640 pz



ECL4080 2

Falso polo con uscita Ø9 mm
Blank cap with Ø9 mm hole

CONFEZ.
BOX 32 pz
IMBALLO
PACKAGE 640 pz



ECL4090 3

Copritasto singolo
Key cover

CONFEZ.
BOX 50 pz
IMBALLO
PACKAGE 1000 pz



ECL4090 4

Copritasto singolo illuminabile
Lightable key cover

CONFEZ.
BOX 50 pz
IMBALLO
PACKAGE 1000 pz



ECL4090 5

Copritasto singolo
per interruttore bipolare
Key cover for 1 way
double poles switch

CONFEZ.
BOX 50 pz
IMBALLO
PACKAGE 1000 pz



ECL4090 6

Copritasto singolo illuminabile
per interruttore bipolare
Lightable key cover for 1 way
double poles switch

CONFEZ.
BOX 50 pz
IMBALLO
PACKAGE 1000 pz



ECL4090 7

Copritasto singolo
per pulsante generico
Key cover
for push button

CONFEZ.
BOX 50 pz
IMBALLO
PACKAGE 1000 pz



ECL4090 8

Copritasto singolo illuminabile
per pulsante generico
Lightable key cover
for push button

CONFEZ.
BOX 50 pz
IMBALLO
PACKAGE 1000 pz



ECL4090 9

Copritasto
pulsante simbolo chiave
Key cover for push button
with key symbol

CONFEZ.
BOX 50 pz
IMBALLO
PACKAGE 1000 pz



ECL4090 10

Copritasto
pulsante simbolo luce
Key cover for push button
with lamp symbol

CONFEZ.
BOX 50 pz
IMBALLO
PACKAGE 1000 pz



ECL4090 11

Copritasto
pulsante simbolo campanello
Key cover for push button
with bell symbol

CONFEZ.
BOX 50 pz
IMBALLO
PACKAGE 1000 pz



ECL4090 12

Copritasto
pulsante simbolo infermiera
Key cover for push button
with nurse symbol

CONFEZ.
BOX 50 pz
IMBALLO
PACKAGE 1000 pz



COPRITASTI INTERCAMBIABILI 2 MODULI 2 MODULES INTERCHANGEABLE COVERS



ECL4090 13

Copritasto doppio
Double key cover

CONFEZ.
BOX 6 pz
IMBALLO
PACKAGE 120 pz



ECL4090 14

Copritasto doppio illuminabile
Lightable double key cover

CONFEZ.
BOX 6 pz
IMBALLO
PACKAGE 120 pz



ECL4090 15

Copritasto doppio bipolare
Double key cover
for 1 way double poles switch

CONFEZ.
BOX 6 pz
IMBALLO
PACKAGE 120 pz

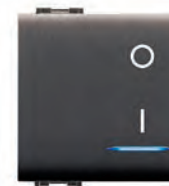

ECL4090 16

Copritasto doppio bipolare illuminabile
Lightable double key cover
for 1 way double poles switch

CONFEZ.
BOX 6 pz
IMBALLO
PACKAGE 120 pz



COPRITASTI INTERCAMBIABILI 3 MODULI 3 MODULES INTERCHANGEABLE COVERS



ECL4090 17

Copritasto triplo
Triple key cover

CONFEZ. BOX 4 pz
IMBALLO PACKAGE 80 pz



ECL4090 18

Copritasto triplo illuminabile
Lightable triple key cover

CONFEZ. BOX 4 pz
IMBALLO PACKAGE 80 pz



ECL4090 19

Copritasto triplo bipolare
Triple key cover for 1 way double poles switch

CONFEZ. BOX 4 pz
IMBALLO PACKAGE 80 pz



ECL4090 20

Copritasto triplo bipolare illuminabile
Lightable triple key cover for 1 way double poles switch

CONFEZ. BOX 4 pz
IMBALLO PACKAGE 80 pz



SUPPORTI A PARETE MYLIFE® MYLIFE® WALL FRAMES



ECL4603F

Supporto 3 moduli con viti
aggancio frutti frontale
3 modules frame with screws front docking

CONFEZ. BOX 100 pz



ECL4604F

Supporto 4 moduli con viti - aggancio frutti frontale
4 modules frame with screws - front docking

CONFEZ. BOX 20 pz
IMBALLO PACKAGE 160 pz



ECL4607F

Supporto 7 moduli con viti - aggancio frutti frontale
7 modules frame with screws - front docking

CONFEZ. BOX 10 pz
IMBALLO PACKAGE 80 pz



SUPPORTI PER PROFILATI O PANNELLI PROFILES OR PANELS FRAMES



NOVITÀ NEW

ECL4609AC

Supporto placca con viti per installazione su profilati o pannelli
1 modulo - Completo di scatola di da incasso dedicata
Cover plate frame with screws for installation on profiles or panels 1 module - Completed with dedicated wall box

CONFEZ. BOX 1 pz
IMBALLO PACKAGE 25 pz

Colore alluminio chiaro
Light aluminium colour



NOVITÀ NEW

ECL4609WH

Supporto placca con viti per installazione su profilati o pannelli
1 modulo - Completo di scatola di da incasso dedicata
Cover plate frame with screws for installation on profiles or panels 1 module - Completed with dedicated wall box

CONFEZ. BOX 1 pz
IMBALLO PACKAGE 25 pz

Colore bianco
White colour



NOVITÀ NEW

ECL4609N

Supporto placca con viti per installazione su profilati o pannelli
1 modulo - Completo di scatola di da incasso dedicata
Cover plate frame with screws for installation on profiles or panels 1 module - Completed with dedicated wall box

CONFEZ. BOX 1 pz
IMBALLO PACKAGE 25 pz

Colore nero
Black colour



ADATTATORI E SUPPORTI SPECIALI ADAPTERS AND SPECIAL WALL FRAMES



ECL4608

Adattatore per: 2 moduli Serie myLife
3 moduli Barra Din
Adapter for: 2 modules myLife Series 3 modules Din Bar

CONFEZ. BOX 40 pz



Questi apparecchi si utilizzano per differenziare in modo inequivocabile alcune sezioni dell'impianto elettrico destinate ad utenze specifiche di determinati ambienti così da evitare la connessione di utilizzatori non previsti per questi particolari punti presa.

These devices are used to unmistakably distinguish some sections of the electrical system. These sections are reserved to specific devices in some particular environments. In this way it's possible to prevent the connection of devices that are not suited for these particular sockets.



ROSSO RED

Alimentazione continua garantita tramite Gruppo di Continuità (UPS) e separata dalla rete attraverso un trasformatore d'isolamento. Apparecchiature mediche per sale operatorie, apparecchiature per dialisi, computer, registratori di cassa, apparecchiature che richiedono separazione dalla rete e continuità nell'alimentazione senza cadute di tensione.

Continuous power supply assured by a Uninterruptible Power Supply (UPS) and separated from the main electrical grid by an isolation transformer. For medical equipment in operating rooms, dialysis equipment, computers, cash registers, any equipment which requires a separation from the main electrical grid and a continuous power supply without tension drops.

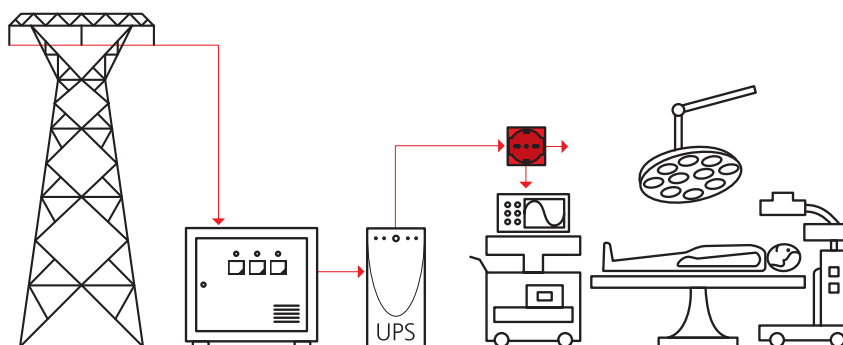

ECL4045 R

Presca italiana bivalente con sicurezza
Italian double shuttered socket



CONFEZ. BOX 12 pz
IMBALLO PACKAGE 240 pz

10/16A 250V~
2P + ⊕
Standard P17/11



ECL4046 R

Presca italiana con sicurezza
2 moduli
Italian shuttered socket
2 modules



CONFEZ. BOX 6 pz
IMBALLO PACKAGE 120 pz

16A 250V~
2P + ⊕ centrale/central
Standard P30



ECL4050 R

Presca italiana/tedesca trivalente con sicurezza
2 moduli
Italian/German triple shuttered socket
2 modules



CONFEZ. BOX 6 pz
IMBALLO PACKAGE 120 pz

10/16A 250V~
2P + ⊕ centrale/central
Standard P40

ARANCIO ORANGE

Alimentazione non continua, protetta dalle interruzioni della rete elettrica con un gruppo elettrogeno e separata dalla stessa con un trasformatore d'isolamento.

Apparecchiature mediche non vitali, strumenti di laboratorio, apparecchiature in genere che accettano brevi mancanze di corrente ma richiedono la separazione dalla rete elettrica.

Not continuous power supply, protected from the disruption of the main electrical grid by a Standby Generator and separated by an isolation transformer.

For not vital medical equipment, laboratory instruments, any equipment accepting short power failures and requiring separation from the main electrical grid.

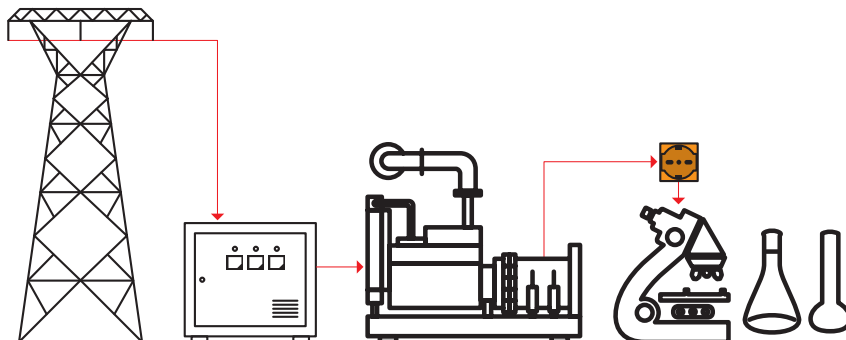

ECL4045 AR

Pres a italiana bivalente con sicurezza
Italian double shuttered socket

CONFEZ. BOX 12 pz
IMBALLO PACKAGE 240 pz

10/16A 250V~
2P + ⊕
Standard P17/11



ECL4046 AR

Pres a italiana con sicurezza
2 moduli
*Italian shuttered socket
2 modules*

CONFEZ. BOX 6 pz
IMBALLO PACKAGE 120 pz

16A 250V~
2P + ⊕ centrale/central
Standard P30



ECL4050 AR

Pres a italiana/tedesca trivalente con sicurezza
2 moduli
*Italian/German triple shuttered socket
2 modules*

CONFEZ. BOX 6 pz
IMBALLO PACKAGE 120 pz

10/16A 250V~
2P + ⊕ centrale/central
Standard P40

VERDE GREEN

Alimentazione non continua, protetta dalle interruzioni della rete elettrica con un gruppo elettrogeno.

Apparecchiature mediche non vitali, strumenti di laboratorio, apparecchi frigoriferi, apparecchiature in genere che accettano brevi mancanze di corrente ma non richiedono la separazione dalla rete elettrica.

Not continuous power supply, protected from the disruption of the main electrical grid by a Standby Generator.

For not vital medical equipment, laboratory instruments, refrigerating equipment.

Any equipment accepting short power failures and not requiring separation from the main electric grid.

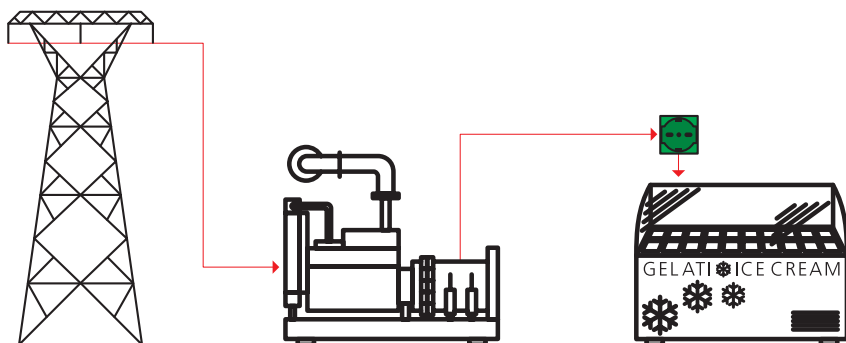

ECL4045 V

Pres a italiana bivalente con sicurezza
Italian double shuttered socket

CONFEZ. BOX 12 pz
IMBALLO PACKAGE 240 pz

10/16A 250V~
2P + ⊕
Standard P17/11



ECL4046 V

Pres a italiana con sicurezza
2 moduli
*Italian shuttered socket
2 modules*

CONFEZ. BOX 6 pz
IMBALLO PACKAGE 120 pz

16A 250V~
2P + ⊕ centrale/central
Standard P30



ECL4050 V

Pres a italiana/tedesca trivalente con sicurezza
2 moduli
*Italian/German triple shuttered socket
2 modules*

CONFEZ. BOX 6 pz
IMBALLO PACKAGE 120 pz

10/16A 250V~
2P + ⊕ centrale/central
Standard P40



Elettrocantali presenta una nuova serie residenziale MYLIFE® con caratteristiche antibatteriche, appositamente studiata per gli ambienti in cui l'igiene è imprescindibile, come strutture ospedaliere, case di cura, ambulatori, scuole, strutture per l'infanzia, uffici, attività commerciali e pubblici esercizi, aree comuni sia condominiali che alberghiere. La nuova MYLIFE® ANTIBATTERICA nasce dall'esigenza sempre più pressante di rendere sicuri gli ambienti in cui è possibile la proliferazione dei batteri dovuti anche al contatto e all'utilizzo di punti luce da parte di più persone. Grazie alla collaborazione con un'azienda leader del settore, le superfici di contatto della nuova linea sono realizzate in uno speciale materiale agli ioni di argento, in grado di eliminare fino al 99,99% della carica microbica e ridurre il potenziale di contaminazione di comandi e prese.

Elettrocantali presents a new residential series MYLIFE® with antibacterial characteristics, specially designed for environments where hygiene is essential, such as hospitals, nursing homes, clinics, schools, childcare facilities, offices, commercial activities and public businesses, common areas, both condominium and hotel. The new MYLIFE® ANTIBACTERIAL arises from the increasingly pressing need to make safe environments in which the proliferation of bacteria is possible, also due to the contact and use of light points by several people. Thanks to the collaboration with a leading company in the sector, the contact surfaces of the new line are made of a special material with silver ions, capable of eliminating until 99,99% of the microbial load and reduce the potential for contamination of controls and sockets.

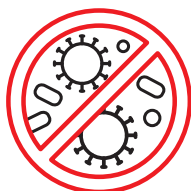

**ELIMINA I MICROBI AL
99,99%
OF MICROBES KILLED**



**PROTEZIONE CONTINUA
E DURATA A VITA
CONTINUOUS PROTECTION
& LIFELONG ENDURANCE**



**NIENTE PIÙ MACCHIE
DOVUTE AI MICROBI
NO MORE STAINS
DUE TO MICROBES**

Questo speciale trattamento antimicrobico ha dimostrato essere efficace contro molti microbi tra cui: staphylococcus aureus, escherichia coli, salmonella, listeria, legionella, campylobacter, pseudomonas, shigella, aspergillus Niger, virus influenza H1N1 e coronavirus felino, ceppo Munich.

This special antimicrobial treatment has been shown to be effective against many microbes including: staphylococcus aureus, escherichia coli, salmonella, listeria, legionella, campylobacter, pseudomonas, shigella, aspergillus Niger, H1N1 influenza virus and feline coronavirus, Munich strain.

La tecnologia protettiva di MYLIFE® ANTIBATTERICA è:

Protective technology of MYLIFE® ANTIBACTERIAL is:

- **PERMANENTE** garantisce una protezione intrinseca durante il tempo di vita atteso dei prodotti;
 - **EFFICACE** contro una gran parte di batteri, microbi, muffe e anche alcuni virus;
 - **SICURA** perché non altera la sicurezza e le relative prestazioni dell'impianto elettrico;
 - **FACILE** perché non cambia le modalità di installazione dei prodotti.
- La linea MYLIFE® ANTIBATTERICA è costituita da una speciale gamma di placche e da apparecchi modulari ad alta rotazione.

- **PERMANENT** guarantees intrinsic protection during the expected life time of the products;
 - **EFFECTIVE** against a large part of bacteria, microbes, molds and even some viruses;
 - **SAFE** because it does not alter the safety and relative performance of the electrical system;
 - **EASY** because it does not change the way the products are installed.
- The MYLIFE® ANTIBACTERIAL line is made up of a special range of plates and high rotation modular devices.

APPARECCHI DI COMANDO BASE BASIC SWITCHING DEVICES



ECL4000 WHAB

Interruttore unipolare con antibatterico
1 way single pole switch with antibacterial

CONF. BOX 12 pz
IMBALLO PACKAGE 240 pz
16AX 250V~



ECL4003 WHAB

Deviatore unipolare con antibatterico
2 way single pole switch with antibacterial

CONF. BOX 12 pz
IMBALLO PACKAGE 240 pz
16AX 250V~



ECL4006 WHAB

Invertitore unipolare con antibatterico
Intermediate single pole switch with antibacterial

CONF. BOX 12 pz
IMBALLO PACKAGE 240 pz
16AX 250V~



ECL4009 WHAB

Interruttore bipolare con antibatterico
1 way double pole switch with antibacterial

CONF. BOX 12 pz
IMBALLO PACKAGE 240 pz
16AX 250V~

Specifiche tecniche a pag. 119
Technical features page 119



ECL4021 WHAB

Pulsante unipolare generico con antibatterico
Push button with antibacterial

CONF. BOX 12 pz
IMBALLO PACKAGE 240 pz
16A 250V~ 1PNO



ECL4021 NCWHAB

Pulsante unipolare normalmente chiuso con antibatterico
Normally closed push button with antibacterial

CONF. BOX 12 pz
IMBALLO PACKAGE 240 pz
16A 250V~ 1PNC

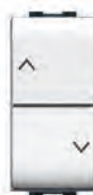

ECL4022 WHAB

Doppio pulsante interbloccato (1PNO)+(1PNO) con antibatterico
Interlocked twin single pole push button (1PNO)+(1PNO) with antibacterial

CONF. BOX 12 pz
IMBALLO PACKAGE 240 pz
10A 250V~



ECL4024 WHAB

Pulsante unipolare a tirante con antibatterico
Push button with cord with antibacterial

CONF. BOX 6 pz
IMBALLO PACKAGE 120 pz
Lunghezza cordino 1,5m
Cord length 1,5m
16A 250V~ 1PNO

PRESE DI CORRENTE OUTLET SOCKETS



ECL4039 WHAB
Pres a italiana con sicurezza
con antibatterico
*Italian shuttered socket
with antibacterial*

CONFEZ.
BOX 12 pz
IMBALLO
PACKAGE 240 pz



ECL4045 WHAB
Pres a italiana bivalente con sicurezza
con antibatterico
*Italian double shuttered socket
with antibacterial*

CONFEZ.
BOX 12 pz
IMBALLO
PACKAGE 240 pz



ECL4046 WHAB
Pres a italiana con sicurezza
con antibatterico - 2 moduli
*Italian shuttered socket
with antibacterial - 2 modules*

CONFEZ.
BOX 6 pz
IMBALLO
PACKAGE 120 pz



ECL4050 WHAB
Pres a italiana/tedesca trivalente con sicurezza
con antibatterico - 2 moduli
*Italian/German triple shuttered socket
with antibacterial - 2 modules*

CONFEZ.
BOX 6 pz
IMBALLO
PACKAGE 120 pz



PRESE PER IMPIANTI DEDICATI OUTLET SOCKETS FOR DEDICATED EQUIPMENTS

ROSSO RED



ECL4045 RAB
Pres a italiana bivalente con sicurezza
con antibatterico
*Italian double shuttered socket
with antibacterial*

CONFEZ.
BOX 12 pz
IMBALLO
PACKAGE 240 pz



ECL4046 RAB
Pres a italiana con sicurezza
con antibatterico - 2 moduli
*Italian shuttered socket
with antibacterial - 2 modules*

CONFEZ.
BOX 6 pz
IMBALLO
PACKAGE 120 pz

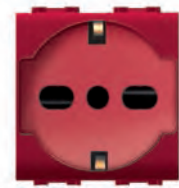

ECL4050 RAB
Pres a italiana/tedesca trivalente con sicurezza
con antibatterico - 2 moduli
*Italian/German triple shuttered socket
with antibacterial - 2 modules*

CONFEZ.
BOX 6 pz
IMBALLO
PACKAGE 120 pz



ARANCIO ORANGE



ECL4045 ARAB
Pres a italiana bivalente con sicurezza
con antibatterico
*Italian double shuttered socket
with antibacterial*

CONFEZ.
BOX 12 pz
IMBALLO
PACKAGE 240 pz



ECL4046 ARAB
Pres a italiana con sicurezza
con antibatterico - 2 moduli
*Italian shuttered socket
with antibacterial - 2 modules*

CONFEZ.
BOX 6 pz
IMBALLO
PACKAGE 120 pz



ECL4050 ARAB
Pres a italiana/tedesca trivalente con sicurezza
con antibatterico - 2 moduli
*Italian/German triple shuttered socket
with antibacterial - 2 modules*

CONFEZ.
BOX 6 pz
IMBALLO
PACKAGE 120 pz



VERDE GREEN



ECL4045 VAB
Pres a italiana bivalente con sicurezza
con antibatterico
*Italian double shuttered socket
with antibacterial*

CONFEZ.
BOX 12 pz
IMBALLO
PACKAGE 240 pz



ECL4046 VAB
Pres a italiana con sicurezza
con antibatterico - 2 moduli
*Italian shuttered socket
with antibacterial - 2 modules*

CONFEZ.
BOX 6 pz
IMBALLO
PACKAGE 120 pz

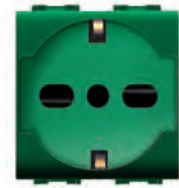

ECL4050 VAB
Pres a italiana/tedesca trivalente con sicurezza
con antibatterico - 2 moduli
*Italian/German triple shuttered socket
with antibacterial - 2 modules*

CONFEZ.
BOX 6 pz
IMBALLO
PACKAGE 120 pz



PRESE TELEFONICHE E TRASMISSIONE DATI TELEPHONE AND DATA SOCKETS

Specifiche tecniche a pag. 122, 123, 124
Technical features page 122, 123, 124



ECL4082 WHAB

Presa telefonica RJ11 plug 6/4
RJ12 plug 6/6 autocrimpante con antibatterico
Self-crimping telephone socket
RJ11 plug 6/4 RJ12 plug 6/6 with antibacterial

CONFEZ.
BOX 6 pz
IMBALLO
PACKAGE 120 pz



ECL4083 WHAB

Presa RJ45 cat 5e UTP non schermata
autocrimpante con antibatterico
Self-crimping RJ45 socket cat 5e UTP
with antibacterial

CONFEZ.
BOX 6 pz
IMBALLO
PACKAGE 120 pz



ECL4081 WHAB

Alimentatore USB tipo A da incasso con antibatterico
Aggancio Keystone
USB charger A type with antibacterial
Keystone docking

CONFEZ.
BOX 6 pz
IMBALLO
PACKAGE 120 pz

Tensione alimentazione In: 100-240V~ 50/60Hz
Tensione alimentazione Out: 5Vdc 2.1A
Input: 100-240V~ 50/60Hz
Output: 5Vdc 2.1A



ECL408301 WHAB

Adattatore Keystone con antibatterico
connettore telefonica/dati
Keystone adapter with antibacterial
telephone/data connector

CONFEZ.
BOX 32 pz
IMBALLO
PACKAGE 640 pz



PRESE TV E SAT TELEVISION AND SATELLITE SOCKETS



ECL4048 1 WHAB

Presa coassiale TV con antibatterico - DIRETTA per impianti monoutenza - PASSANTE per impianti a cascata
TERMINATA con collegamento all'art. ECL20483 per impianti a cascata
TV socket with antibacterial - DIRECT for single user system - PASSING for system with fall distribution
TERMINAL connected with art. ECL20483 for system with fall distribution

CONFEZ.
BOX 12 pz
IMBALLO
PACKAGE 240 pz

Connettore femmina D mm 9,5
Attenuazione di passaggio 0 dB
VHF-UHF (40-860MHz)

Female connector D mm 9,5
Signal attenuation 0 dB
VHF-UHF (40-860MHz)



ECL4048 1MWHAB

Presa coassiale TV con antibatterico - DIRETTA per impianti monoutenza - PASSANTE per impianti a cascata
TERMINATA con collegamento all'art. ECL20483 per impianti a cascata
TV socket with antibacterial - DIRECT for single user system - PASSING for system with fall distribution
TERMINAL connected with art. ECL20483 for system with fall distribution

CONFEZ.
BOX 12 pz
IMBALLO
PACKAGE 240 pz

Connettore maschio
Attenuazione di passaggio 0 dB
VHF-UHF (40-860MHz)

Male connector
Signal attenuation 0 dB
VHF-UHF (40-860MHz)



APPARECCHI DI COMANDO ELETTRONICI ELECTRONIC DEVICES



PER LAMPADE A LED
LED LAMPS

Specifiche tecniche a pag. 129
Technical features page 129

ECL4705 WHAB

Variatore di luminosità universale con antibatterico con deviatore push-push per led dimmerabili
e carichi resistivi/induttivi con punto luminoso rosso per individuazione al buio
Universal dimmerable led light and resistive/inductive dimmer with antibacterial with 2 way single
pole switch. Push action. Red indicator light in the front side

CONFEZ.
BOX 6 pz
IMBALLO
PACKAGE 120 pz

Led dimmerabili/dimmerable led 4W-80W
Resistivi/Resistive 20W-150W
Induttivi/Inductive 20VA-100VA



COPRITASTI INTERCAMBIABILI INTERCHANGEABLE COVERS



ECL4080 WHAB

Falso polo con antibatterico
Blank cap with antibacterial

CONFEZ.
BOX 32 pz
IMBALLO
PACKAGE 640 pz



PLACCHE COPRINTERRUTTORI MYLIFE Q - FINITURA BIANCA MYLIFE Q COVER PLATES - WHITE FINISHES



ECL2882 WHAB

Placca 2 moduli con antibatterico
2 modules cover plates with antibacterial

CONFEZ.
BOX 30 pz
IMBALLO
PACKAGE 360 pz



ECL2883 WHAB

Placca 3 moduli con antibatterico
3 modules cover plates with antibacterial

CONFEZ.
BOX 20 pz
IMBALLO
PACKAGE 240 pz



ECL2884 WHAB

Placca 4 moduli con antibatterico
4 modules cover plates with antibacterial

CONFEZ.
BOX 15 pz
IMBALLO
PACKAGE 180 pz



ECL2887 WHAB

Placca 7 moduli con antibatterico
7 modules cover plates with antibacterial

CONFEZ.
BOX 10 pz
IMBALLO
PACKAGE 120 pz



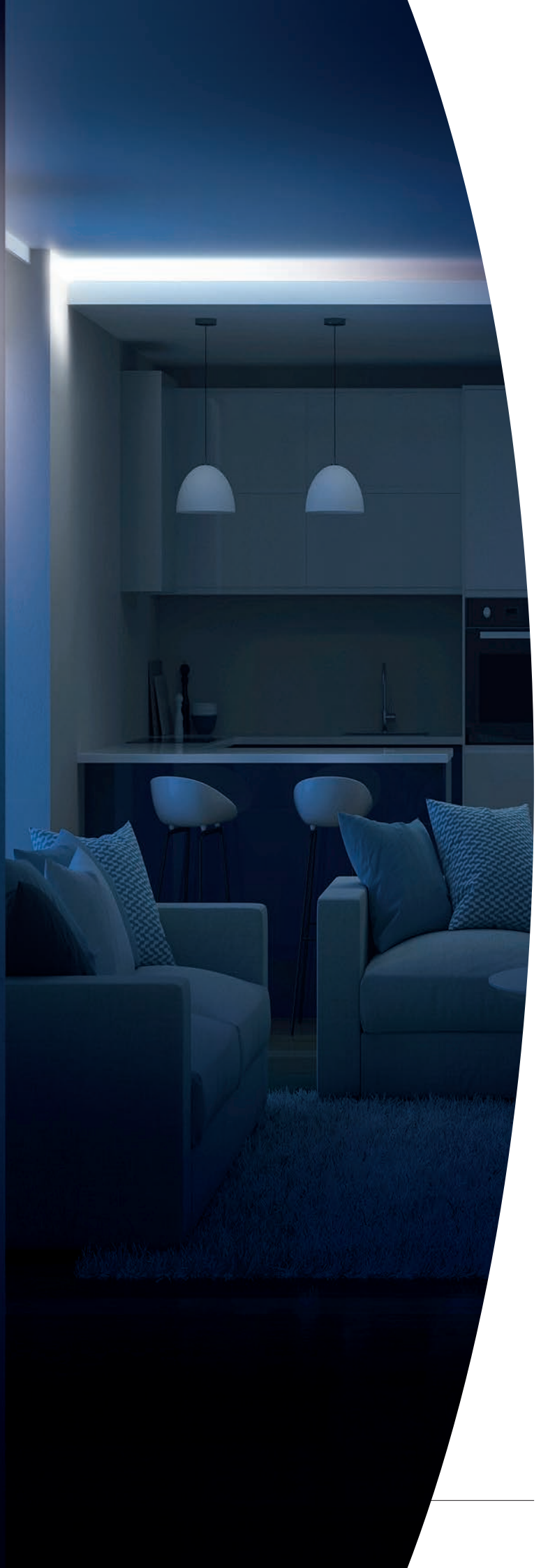



ECL6067

Lampada di emergenza a LED da incasso e da parete predisposta con cassetta di aggancio
Wall and flush mounting LED emergency lamp supplied with docking box

CONFEZ. BOX	1 pz
IMBALLO PACKAGE	20 pz



230V~ 50Hz
Lampada: 30 LED 4W
Intensità Luminosa: 270 lm
Temperatura di funzionamento: 0° +40°
Batteria: Li-Ion 3,7V 3600 mAh
Autonomia: 4h
Tempo di ricarica: 24h
Funzionamento: SE-SA
Normative: EN60598-1, EN60598-2-2, EN62471, EN55015:2006, EN61547

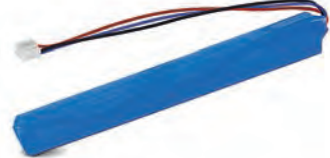

ECL6067B

Batteria sostitutiva per art. ECL6067
Replacement battery for item ECL6067

230V~ 50Hz
Bulb: 30 LED 4W
Brightness: 270lm
Working temperature: 0° + 40°
Battery: 3.7V - 3600 mAh Li-Ion
Autonomy: 4h
Recharge time: 24h
Not maintained (SE) - maintained (SA)
European standards: EN 60598-1, EN 60598-2-2, EN 62471, EN 55015:2006, EN 61547

CONFEZ. BOX	1 pz
-------------	------



LHON 3,7V~ 1,8Ah



ECL6067C

Cornice per installazione lampada emergenza art. ECL6067 su altre scatole
Frame for installation of emergency lamp art. ECL6067 on other boxes

CONFEZ. BOX	1 pz
-------------	------

MONTAGGIO E CABLAGGIO LAMPADA DI EMERGENZA ECL6067 ECL6067 EMERGENCY LAMP INSTALLATION AND WIRING

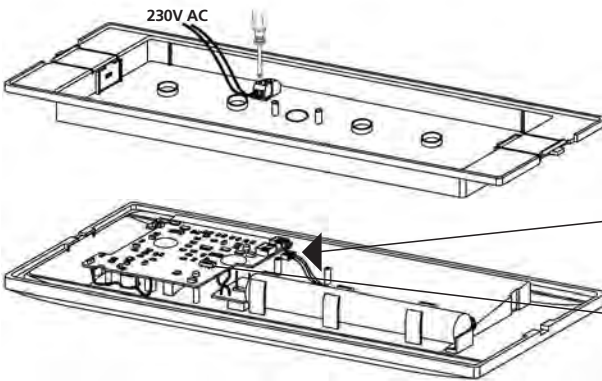

Connettore batteria
Battery connector

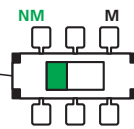

Interruttore a slitta
Spostato a sinistra = SOLO EMERGENZA
Spostato a destra = SEMPRE ACCESA
Slide switch
Moved to left = NOT MAINTAINED
Moved to right = MAINTAINED

INCASSO CON SCATOLA WALL MOUNTING WITH BOX

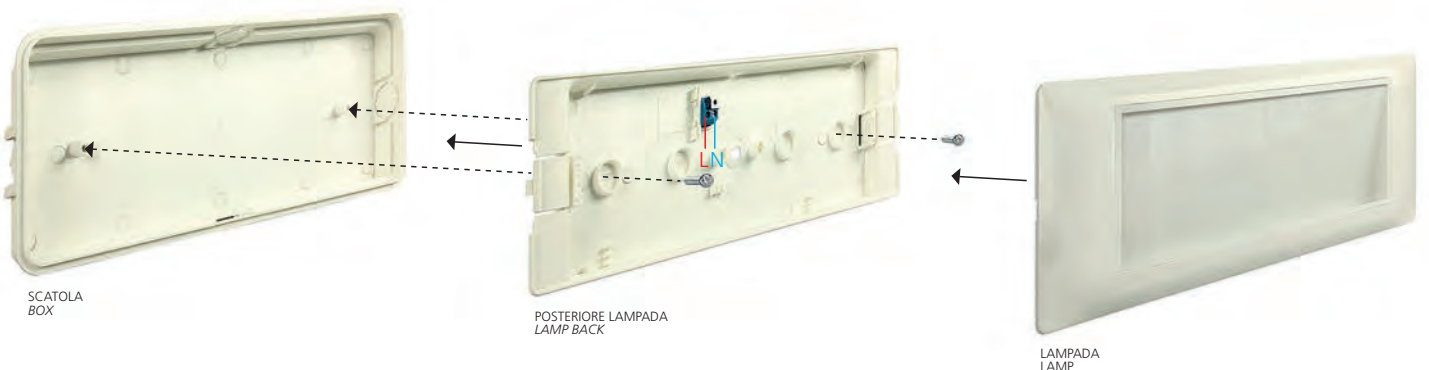

SCATOLA
BOX

POSTERIORE LAMPADA
LAMP BACK

LAMPADA
LAMP

A PARETE CON CORNICE FLUSH MOUNTING WITH FRAME

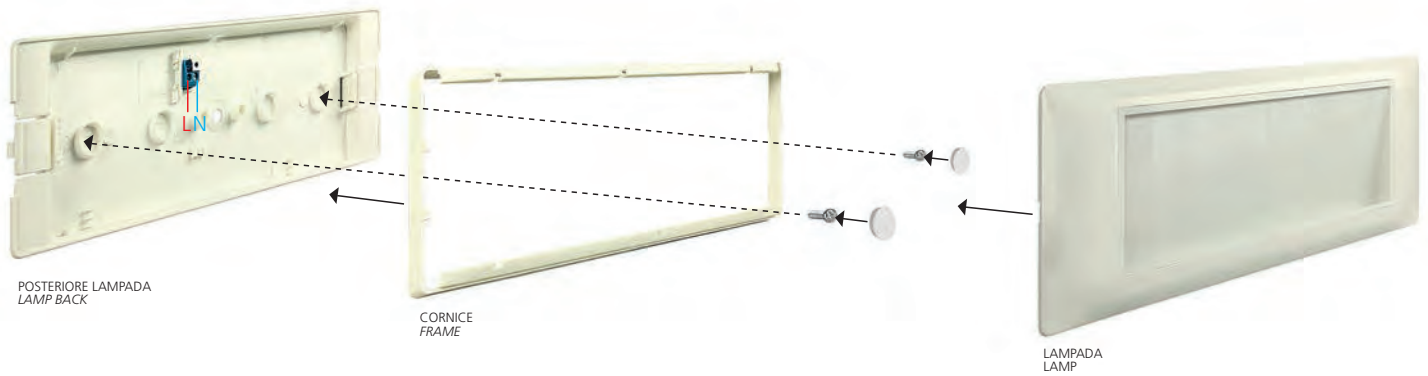

CARTONGESSO CON MOLLE CEILING WITH SPRINGS

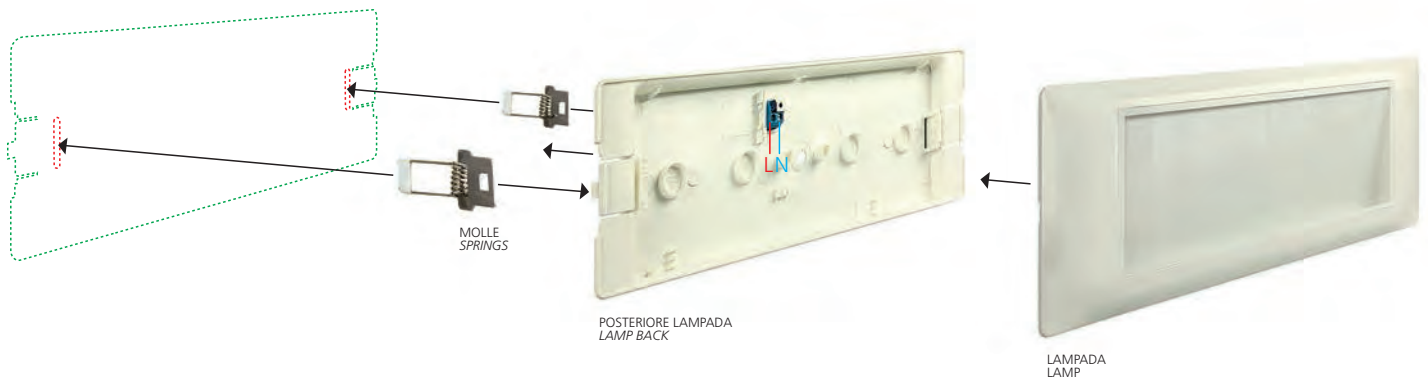

INCASSO IN ALTRE SCATOLE CON ADATTATORE OTHER BOXES WALL MOUNTING WITH ADAPTERS

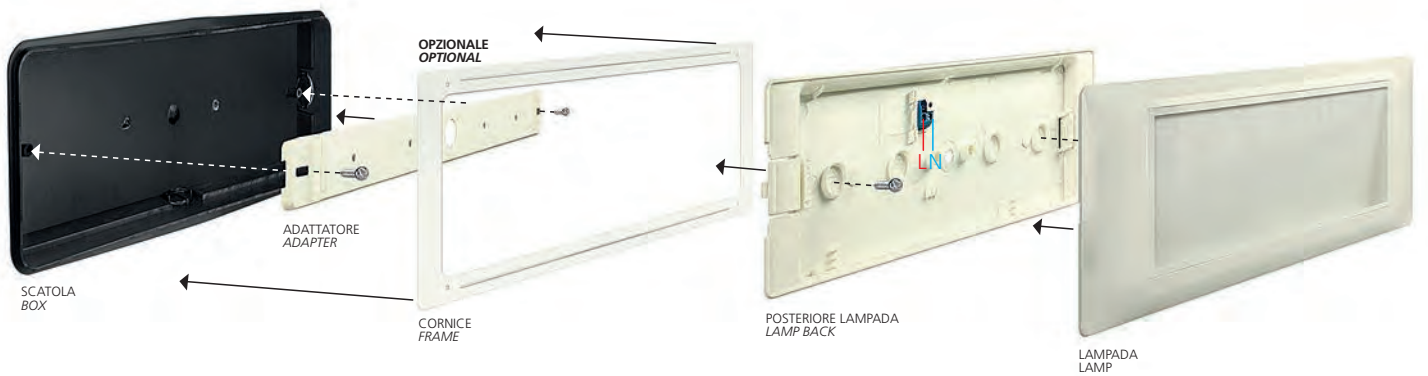

PITTOGRAMMI PER USCITA DI EMERGENZA FORNITI PICTOGRAMS FOR EMERGENCY EXIT PROVIDED

MODALITÀ SEMPRE ACCESA
MAINTENED MODALITY

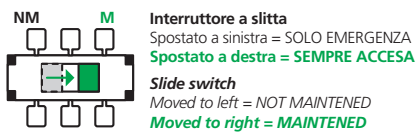



ECL4069L

Lampada fissa di emergenza a LED 7 moduli da incasso predisposta con supporto di aggancio
compatibile con le placche MYLIFE® - MYLIFE Q® - NEW PRESTIGE®
7 modules LED fixed emergency lamp with wall frame included
compatible with MYLIFE® - MYLIFE Q® - NEW PRESTIGE® cover plates

CONF. BOX 1 pz



230V~ 50Hz
Lampada: 2W
Intensità luminosa: 160lm
Autonomia: 3h
Batteria: 3.7V 1.2Ah Li-ion

230V~ 50Hz
Bulb: 2W
Brightness: 160lm
Autonomy: 3h
Battery: 3.7V 1.2Ah Li-ion



ECL4067

Lampada fissa di emergenza a LED 3 moduli da incasso predisposta con supporto di aggancio
compatibile con le placche MYLIFE® - MYLIFE Q® - NEW PRESTIGE®
3 modules LED fixed emergency lamp with wall frame included
compatible with MYLIFE® - MYLIFE Q® - NEW PRESTIGE® cover plates

CONF. BOX 1 pz

IMBALLO PACKAGE 20 pz



230V~ 50Hz
Lampada: 2 LED x 0.4W
Temperatura di funzionamento: 0° + 40°C
Batteria (Ni-Mh) 3.6V 0.080Ah
Autonomia: 1h
Tempo di ricarica: 8h c.a.
Vita min. batteria: 6 anni c.a.

230V~ 50Hz
Bulb: 2 LED x 0.4W
Working temperature: 0° + 40°C
Battery (Ni-Mh) 3.6V 0.080Ah
Autonomy: 1h
Recharging time: 8h about
Battery life time: 6 years about



ECL40671 TEC

Lampada di emergenza a LED 1 modulo aggancio KEYSTONE
1 module LED emergency lamp
KEYSTONE docking

CONF. BOX 6 pz

IMBALLO PACKAGE 30 pz

230V~ 50Hz - Lampada: 1 LED colore bianco
Intensità luminosa: > 5700 mcd @ 3.7mA
Funzioni: ON (SA) - AUTO (SE)
Temperatura di funzionamento: -10° + 40°
Autonomia: 2h - Tempo di ricarica: 3h c.a.
230V~ 50Hz - Bulb: 1 LED white colour
Brightness: > 5700 mcd @ 3.7mA
Function: ON (SA) - AUTO (SE)
Working temperature: -10° + 40°
Autonomy: 2h - Recharging time: 3h about



ECL40671 WH

Lampada di emergenza a LED 1 modulo aggancio KEYSTONE
1 module LED emergency lamp
KEYSTONE docking

CONF. BOX 6 pz

IMBALLO PACKAGE 30 pz

230V~ 50Hz - Lampada: 1 LED colore bianco
Intensità luminosa: > 5700 mcd @ 3.7mA
Funzioni: ON (SA) - AUTO (SE)
Temperatura di funzionamento: -10° + 40°
Autonomia: 2h - Tempo di ricarica: 3h c.a.
230V~ 50Hz - Bulb: 1 LED white colour
Brightness: > 5700 mcd @ 3.7mA
Function: ON (SA) - AUTO (SE)
Working temperature: -10° + 40°
Autonomy: 2h - Recharging time: 3h about



ECL40671

Lampada di emergenza a LED 1 modulo aggancio KEYSTONE
1 module LED emergency lamp
KEYSTONE docking

CONF. BOX 6 pz

IMBALLO PACKAGE 30 pz

230V~ 50Hz - Lampada: 1 LED colore bianco
Intensità luminosa: > 5700 mcd @ 3.7mA
Funzioni: ON (SA) - AUTO (SE)
Temperatura di funzionamento: -10° + 40°
Autonomia: 2h - Tempo di ricarica: 3h c.a.
230V~ 50Hz - Bulb: 1 LED white colour
Brightness: > 5700 mcd @ 3.7mA
Function: ON (SA) - AUTO (SE)
Working temperature: -10° + 40°
Autonomy: 2h - Recharging time: 3h about



ECL4068

Lampada fissa di emergenza POWER LED 3 moduli da incasso predisposta con supporto di aggancio e placca
compatibile con le placche MYLIFE® - MYLIFE Q® - NEW PRESTIGE®
3 modules fixed POWER LED emergency lamp with wall frame and cover plate included
compatible with MYLIFE® - MYLIFE Q® - NEW PRESTIGE® cover plates

CONF. BOX 1 pz

IMBALLO PACKAGE 20 pz



230V~ 50Hz
Lampada: power LED 1W
Intensità luminosa: 50lm
Temperatura di funzionamento: 0° + 40°C
Batteria: (Ni-Mh) 3.6V 0.65Ah
Autonomia: 4 ore
Tempo di ricarica: 12h c.a.
Vita min. batteria: 6 anni
Normativa: EN60598-2-22

230V~ 50Hz
Bulb: power LED 1W
Brightness: 50lm
Working temperature: 0° + 40°C
Battery: (Ni-Mh) 3.6V 0.65Ah
Autonomy: 4 hours
Recharging time: 12h about
Battery life time: 6 years
European standard: EN60598-2-22



ECL40682E

Lampada estraibile di emergenza a LED 2 moduli da incasso predisposta con supporto di aggancio
2 modules extractable LED emergency lamp with wall frame included
Specifiche tecniche a pag. 133
Technical features page 133

CONF. BOX 1 pz

230V~ 50/60Hz
Lampada: 1 LED colore bianco
Intensità luminosa: 20lm
Temperatura di funzionamento: 0° + 40°
Batteria: 3.6V - 0,14 Ah
Autonomia: 2h c.a.
2 LED di segnalazione, attività della lampada:
VERDE (operativo) - ROSSO (inibito)
Tempo di ricarica: max 36h
Normativa: EN 60598-1, EN 60598-2-2, EN62471 55015:2006, EN61547

230V~ 50/60Hz
Bulb: 1 LED white colour
Brightness: 20 lm
Working temperature: 0° + 40°
Battery: 3.6V - 0,14 Ah
Autonomy: 2h about
2 LEDs signals communicate lamp operation condition:
GREEN (operative) - RED (inhibited)
Recharging time: max 36h
European standard: EN 60598-1, EN 60598-2-2, EN62471 55015:2006, EN61547



my life®

Placche coprinterruttori

Qualunque sia la preferenza in termini di colori, stile ed atmosfera sarà facile trovare nella gamma MYLIFE® la combinazione che più si adatta ai propri gusti e necessità.

Le placche coprinterruttori MYLIFE® sono infatti proposte in ben 30 colorazioni suddivise tra 5 differenti finiture d'effetto create per esaltare qualsiasi contesto architettonico, sia esso classico che moderno. Svariate possibilità decorative che elevano la pura funzione trasformandola in una scelta creativa d'arredo.

Cover plates

Whatever your choice in terms of colours, style and feeling, it will be easy to find in the MYLIFE® series the combination that most satisfies your tastes and needs.

MYLIFE® cover plates are proposed in 30 colours with 5 different finishes, created to exalt every architectural style both classic or modern.

Decoration possibilities transform the simple functional solution into a creative furnishing value.



VERSIONI DISPONIBILI AVAILABLE MODELS



3 MODULI 3 MODULES



4 MODULI 4 MODULES



7 MODULI 7 MODULES

Ogni placca MYLIFE® viene fornita con l'adattatore di colore grigio. Le placche "VERDE ACQUA" e quelle "FINITURE PASTELLO" sono invece fornite con adattatori di colore bianco. È possibile sostituire l'adattatore fornito di serie acquistando separatamente gli adattatori nelle altre finiture disponibili. Le foto hanno puramente carattere di presentazione e non sono impegnative in merito all'abbinamento placca-adattatore.

Each MYLIFE® cover plate is supplied with grey adapter. Only "GREEN WATER" and "PASTEL FINISHES" cover plates are supplied with white adapters. It is possible to change the supplied adapter buying separately the other available finishes of adapters. Cover plates pictures have only a presentation purpose and haven't any relevant relationship with cover plates – adapter color matching.

Per la pulizia delle placche MYLIFE® "FINITURE METALLICHE" utilizzare esclusivamente un panno asciutto senza aggiunta di nessun tipo di solvente (spray, ecc.), che potrebbe alterarne i colori.

To clean MYLIFE® "METALLIC FINISHES" cover plates, use only a dry cloth without add any type of cleaning solvent that could alter its original colour.

FINITURE BASE BASIC FINISHES



BIANCO TOTALE TOTAL WHITE

ECL2983 TWH ECL2984 TWH ECL2987 TWH

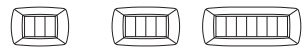

3 MODULI MODULES	4 MODULI MODULES	7 MODULI MODULES
CONFEZ. BOX 20 pz	CONFEZ. BOX 15 pz	CONFEZ. BOX 10 pz
IMBALLO PACKAGE 240 pz	IMBALLO PACKAGE 180 pz	IMBALLO PACKAGE 120 pz

ECL2983 TWH
Fornita con adattatore BIANCO ECL2981-3WH
Supplied with WHITE adapter ECL2981-3WH

ECL2984 TWH
Fornita con adattatore BIANCO ECL2981-4WH
Supplied with WHITE adapter ECL2981-4WH

ECL2987 TWH
Fornita con adattatore BIANCO ECL2981-7WH
Supplied with WHITE adapter ECL2981-7WH



BIANCO WHITE

ECL2983 WH ECL2984 WH ECL2987 WH

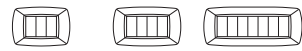

3 MODULI MODULES	4 MODULI MODULES	7 MODULI MODULES
CONFEZ. BOX 20 pz	CONFEZ. BOX 15 pz	CONFEZ. BOX 10 pz
IMBALLO PACKAGE 240 pz	IMBALLO PACKAGE 180 pz	IMBALLO PACKAGE 120 pz



AVORIO IVORY

ECL2983 A ECL2984 A ECL2987 A

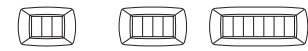

3 MODULI MODULES	4 MODULI MODULES	7 MODULI MODULES
CONFEZ. BOX 20 pz	CONFEZ. BOX 15 pz	CONFEZ. BOX 10 pz
IMBALLO PACKAGE 240 pz	IMBALLO PACKAGE 180 pz	IMBALLO PACKAGE 120 pz



GRIGIO SCURO DARK GREY

ECL2983 GS ECL2984 GS ECL2987 GS

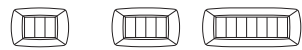

3 MODULI MODULES	4 MODULI MODULES	7 MODULI MODULES
CONFEZ. BOX 20 pz	CONFEZ. BOX 15 pz	CONFEZ. BOX 10 pz
IMBALLO PACKAGE 240 pz	IMBALLO PACKAGE 180 pz	IMBALLO PACKAGE 120 pz



NERO BLACK

ECL2983 N ECL2984 N ECL2987 N

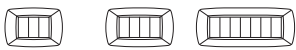

3 MODULI MODULES	4 MODULI MODULES	7 MODULI MODULES
CONFEZ. BOX 20 pz	CONFEZ. BOX 15 pz	CONFEZ. BOX 10 pz
IMBALLO PACKAGE 240 pz	IMBALLO PACKAGE 180 pz	IMBALLO PACKAGE 120 pz



NERO GLITTERING GLITTERING BLACK

ECL2983 NG ECL2984 NG ECL2987 NG

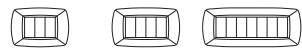

3 MODULI MODULES	4 MODULI MODULES	7 MODULI MODULES
CONFEZ. BOX 20 pz	CONFEZ. BOX 15 pz	CONFEZ. BOX 10 pz
IMBALLO PACKAGE 240 pz	IMBALLO PACKAGE 180 pz	IMBALLO PACKAGE 120 pz



BLU BLUE

ECL2983 BL ECL2984 BL ECL2987 BL

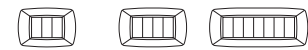

3 MODULI MODULES	4 MODULI MODULES	7 MODULI MODULES
CONFEZ. BOX 20 pz	CONFEZ. BOX 15 pz	CONFEZ. BOX 10 pz
IMBALLO PACKAGE 240 pz	IMBALLO PACKAGE 180 pz	IMBALLO PACKAGE 120 pz



VERDE SCOZIA SCOTTISH GREEN

ECL2983 VS ECL2984 VS ECL2987 VS

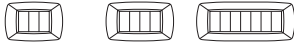

3 MODULI MODULES	4 MODULI MODULES	7 MODULI MODULES
CONFEZ. BOX 20 pz	CONFEZ. BOX 15 pz	CONFEZ. BOX 10 pz
IMBALLO PACKAGE 240 pz	IMBALLO PACKAGE 180 pz	IMBALLO PACKAGE 120 pz



AMARANTO BURGUNDY

ECL2983 AM ECL2984 AM ECL2987 AM

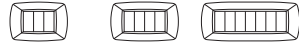

3 MODULI MODULES	4 MODULI MODULES	7 MODULI MODULES
CONFEZ. BOX 20 pz	CONFEZ. BOX 15 pz	CONFEZ. BOX 10 pz
IMBALLO PACKAGE 240 pz	IMBALLO PACKAGE 180 pz	IMBALLO PACKAGE 120 pz



VERDE ACQUA WATER GREEN

ECL2983 VA ECL2984 VA ECL2987 VA

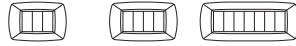

3 MODULI MODULES	4 MODULI MODULES	7 MODULI MODULES
CONFEZ. BOX 20 pz	CONFEZ. BOX 15 pz	CONFEZ. BOX 10 pz
IMBALLO PACKAGE 240 pz	IMBALLO PACKAGE 180 pz	IMBALLO PACKAGE 120 pz

FINITURE PASTELLO PASTEL FINISHES

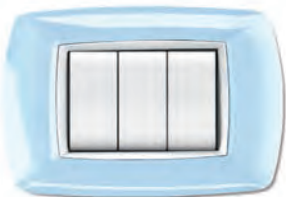

AZZURRO PASTELLO PASTEL AZURE

ECL2983 PA ECL2984 PA ECL2987 PA

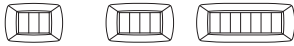

3 MODULI MODULES	4 MODULI MODULES	7 MODULI MODULES
CONFEZ. BOX 20 pz	CONFEZ. BOX 15 pz	CONFEZ. BOX 10 pz
IMBALLO PACKAGE 240 pz	IMBALLO PACKAGE 180 pz	IMBALLO PACKAGE 120 pz



VERDE PASTELLO PASTEL GREEN

ECL2983 PG ECL2984 PG ECL2987 PG

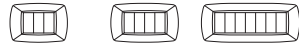

3 MODULI MODULES	4 MODULI MODULES	7 MODULI MODULES
CONFEZ. BOX 20 pz	CONFEZ. BOX 15 pz	CONFEZ. BOX 10 pz
IMBALLO PACKAGE 240 pz	IMBALLO PACKAGE 180 pz	IMBALLO PACKAGE 120 pz



GIALLO PASTELLO PASTEL YELLOW

ECL2983 PY ECL2984 PY ECL2987 PY

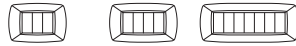

3 MODULI MODULES	4 MODULI MODULES	7 MODULI MODULES
CONFEZ. BOX 20 pz	CONFEZ. BOX 15 pz	CONFEZ. BOX 10 pz
IMBALLO PACKAGE 240 pz	IMBALLO PACKAGE 180 pz	IMBALLO PACKAGE 120 pz



ARANCIO PASTELLO PASTEL ORANGE

ECL2983 PO ECL2984 PO ECL2987 PO

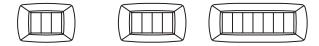

3 MODULI MODULES	4 MODULI MODULES	7 MODULI MODULES
CONFEZ. BOX 20 pz	CONFEZ. BOX 15 pz	CONFEZ. BOX 10 pz
IMBALLO PACKAGE 240 pz	IMBALLO PACKAGE 180 pz	IMBALLO PACKAGE 120 pz

FINITURE METALLICHE METALLIC FINISHES



ALLUMINIO CHIARO LIGHT ALUMINIUM

ECL2983 AC ECL2984 AC ECL2987 AC

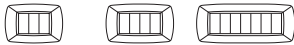

3 MODULI MODULES	4 MODULI MODULES	7 MODULI MODULES
CONFEZ. BOX 20 pz	CONFEZ. BOX 15 pz	CONFEZ. BOX 10 pz
IMBALLO PACKAGE 240 pz	IMBALLO PACKAGE 180 pz	IMBALLO PACKAGE 120 pz



ALLUMINIO NOTTE DARK ALUMINIUM

ECL2983 AN ECL2984 AN ECL2987 AN

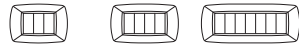

3 MODULI MODULES	4 MODULI MODULES	7 MODULI MODULES
CONFEZ. BOX 20 pz	CONFEZ. BOX 15 pz	CONFEZ. BOX 10 pz
IMBALLO PACKAGE 240 pz	IMBALLO PACKAGE 180 pz	IMBALLO PACKAGE 120 pz



RAME COPPER

ECL2983 RM ECL2984 RM ECL2987 RM

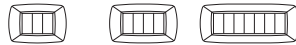

3 MODULI MODULES	4 MODULI MODULES	7 MODULI MODULES
CONFEZ. BOX 20 pz	CONFEZ. BOX 15 pz	CONFEZ. BOX 10 pz
IMBALLO PACKAGE 240 pz	IMBALLO PACKAGE 180 pz	IMBALLO PACKAGE 120 pz



ACCIAIO SATINATO SATIN STEEL

ECL2983 AS ECL2984 AS ECL2987 AS

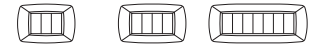

3 MODULI MODULES	4 MODULI MODULES	7 MODULI MODULES
CONFEZ. BOX 20 pz	CONFEZ. BOX 15 pz	CONFEZ. BOX 10 pz
IMBALLO PACKAGE 240 pz	IMBALLO PACKAGE 180 pz	IMBALLO PACKAGE 120 pz



METAL BLACK

ECL2983 MB ECL2984 MB ECL2987 MB

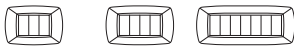

3 MODULI MODULES	4 MODULI MODULES	7 MODULI MODULES
CONFEZ. BOX 20 pz	CONFEZ. BOX 15 pz	CONFEZ. BOX 10 pz
IMBALLO PACKAGE 240 pz	IMBALLO PACKAGE 180 pz	IMBALLO PACKAGE 120 pz



CROMO CHROME

ECL2983 CR ECL2984 CR ECL2987 CR

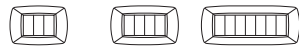

3 MODULI MODULES	4 MODULI MODULES	7 MODULI MODULES
CONFEZ. BOX 20 pz	CONFEZ. BOX 15 pz	CONFEZ. BOX 10 pz
IMBALLO PACKAGE 240 pz	IMBALLO PACKAGE 180 pz	IMBALLO PACKAGE 120 pz



ORO GOLD *

ECL2983 OR ECL2984 OR ECL2987 OR

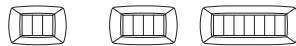

3 MODULI MODULES	4 MODULI MODULES	7 MODULI MODULES
CONFEZ. BOX 20 pz	CONFEZ. BOX 15 pz	CONFEZ. BOX 10 pz
IMBALLO PACKAGE 240 pz	IMBALLO PACKAGE 180 pz	IMBALLO PACKAGE 120 pz

* Realizzata con bagno galvanico in oro 24 kt
Galvanic coating with 24 kt gold

FINITURE VULCANIZZATE VULCANISED FINISHES



GRIGIO NOTTE DARK GREY

ECL2983 V-GN ECL2984 V-GN ECL2987 V-GN

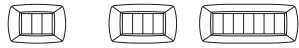

3 MODULI MODULES	4 MODULI MODULES	7 MODULI MODULES
CONFEZ. BOX 20 pz	CONFEZ. BOX 15 pz	CONFEZ. BOX 10 pz
IMBALLO PACKAGE 240 pz	IMBALLO PACKAGE 180 pz	IMBALLO PACKAGE 120 pz



GRIGIO CHIARO LIGHT GREY

ECL2983 V-GC ECL2984 V-GC ECL2987 V-GC

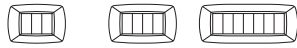

3 MODULI MODULES	4 MODULI MODULES	7 MODULI MODULES
CONFEZ. BOX 20 pz	CONFEZ. BOX 15 pz	CONFEZ. BOX 10 pz
IMBALLO PACKAGE 240 pz	IMBALLO PACKAGE 180 pz	IMBALLO PACKAGE 120 pz



CARTA DA ZUCCHERO LIGHT BLUE

ECL2983 V-CZ ECL2984 V-CZ ECL2987 V-CZ

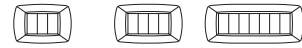

3 MODULI MODULES	4 MODULI MODULES	7 MODULI MODULES
CONFEZ. BOX 20 pz	CONFEZ. BOX 15 pz	CONFEZ. BOX 10 pz
IMBALLO PACKAGE 240 pz	IMBALLO PACKAGE 180 pz	IMBALLO PACKAGE 120 pz



VERDE NOTTE DARK GREEN

ECL2983 V-VN ECL2984 V-VN ECL2987 V-VN

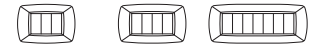

3 MODULI MODULES	4 MODULI MODULES	7 MODULI MODULES
CONFEZ. BOX 20 pz	CONFEZ. BOX 15 pz	CONFEZ. BOX 10 pz
IMBALLO PACKAGE 240 pz	IMBALLO PACKAGE 180 pz	IMBALLO PACKAGE 120 pz



ARAGOSTA LOBSTER RED

ECL2983 V-AR ECL2984 V-AR ECL2987 V-AR

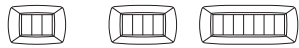

3 MODULI MODULES	4 MODULI MODULES	7 MODULI MODULES
CONFEZ. BOX 20 pz	CONFEZ. BOX 15 pz	CONFEZ. BOX 10 pz
IMBALLO PACKAGE 240 pz	IMBALLO PACKAGE 180 pz	IMBALLO PACKAGE 120 pz

FINITURE LEGNO WOODEN-LIKE FINISHES



BETULLA BIRCH

ECL2983 BT ECL2984 BT ECL2987 BT

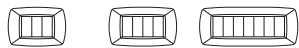

3 MODULI MODULES	4 MODULI MODULES	7 MODULI MODULES
CONFEZ. BOX 20 pz	CONFEZ. BOX 15 pz	CONFEZ. BOX 10 pz
IMBALLO PACKAGE 240 pz	IMBALLO PACKAGE 180 pz	IMBALLO PACKAGE 120 pz



LEGNO CHIARO LIGHT WOOD

ECL2983 LC ECL2984 LC ECL2987 LC

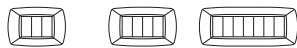

3 MODULI MODULES	4 MODULI MODULES	7 MODULI MODULES
CONFEZ. BOX 20 pz	CONFEZ. BOX 15 pz	CONFEZ. BOX 10 pz
IMBALLO PACKAGE 240 pz	IMBALLO PACKAGE 180 pz	IMBALLO PACKAGE 120 pz



LEGNO SCURO DARK WOOD

ECL2983 LS ECL2984 LS ECL2987 LS

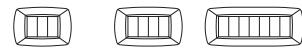

3 MODULI MODULES	4 MODULI MODULES	7 MODULI MODULES
CONFEZ. BOX 20 pz	CONFEZ. BOX 15 pz	CONFEZ. BOX 10 pz
IMBALLO PACKAGE 240 pz	IMBALLO PACKAGE 180 pz	IMBALLO PACKAGE 120 pz



RADICA BURL WOOD

ECL2983 RA ECL2984 RA ECL2987 RA

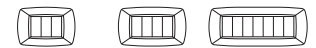

3 MODULI MODULES	4 MODULI MODULES	7 MODULI MODULES
CONFEZ. BOX 20 pz	CONFEZ. BOX 15 pz	CONFEZ. BOX 10 pz
IMBALLO PACKAGE 240 pz	IMBALLO PACKAGE 180 pz	IMBALLO PACKAGE 120 pz



WENGE

ECL2983 WG ECL2984 WG ECL2987 WG

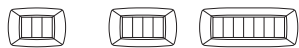

3 MODULI MODULES	4 MODULI MODULES	7 MODULI MODULES
CONFEZ. BOX 20 pz	CONFEZ. BOX 15 pz	CONFEZ. BOX 10 pz
IMBALLO PACKAGE 240 pz	IMBALLO PACKAGE 180 pz	IMBALLO PACKAGE 120 pz

Il segreto della serie Life MYLIFE® è nei pratici adattatori. Gli adattatori permettono di fissare le placche coprinterruttori MYLIFE® ai supporti a parete mediante un semplice gesto: una leggerissima pressione sulla placca ed il gioco è fatto.

Ogni placca MYLIFE® viene fornita sia con l'adattatore per supporto MYLIFE® che con un adattatore per altre serie aventi lo stesso standard. Ogni adattatore è comunque ordinabile anche separatamente per eventuali predisposizioni.

The secret of the MYLIFE® series lies in its functional adapters. The adapters allow MYLIFE® cover plates be fixed to the wall frames by means of a simple gesture: a light pressure on the cover and all is done.

Every MYLIFE® plate is supplied both with the adapter for MYLIFE® frames, both with an adapter for other series with the same standard. In any case, additional adapters could be ordered separately for other possible uses.

ADATTATORI PER SUPPORTI MYLIFE® ADAPTERS FOR MYLIFE® WALL FRAMES

GRIGIO GREY			BIANCO WHITE			CROMO CHROME		
ECL2981-3	ECL2981-4	ECL2981-7	ECL2981-3WH	ECL2981-4WH	ECL2981-7WH	ECL2981-3CR	ECL2981-4CR	ECL2981-7CR
3 MODULI MODULES	4 MODULI MODULES	7 MODULI MODULES	3 MODULI MODULES	4 MODULI MODULES	7 MODULI MODULES	3 MODULI MODULES	4 MODULI MODULES	7 MODULI MODULES
CONFEZ. BOX 50 pz	CONFEZ. BOX 40 pz	CONFEZ. BOX 25 pz	CONFEZ. BOX 50 pz	CONFEZ. BOX 40 pz	CONFEZ. BOX 25 pz	CONFEZ. BOX 50 pz	CONFEZ. BOX 40 pz	CONFEZ. BOX 25 pz
IMBALLO PACKAGE 800 pz	IMBALLO PACKAGE 640 pz	IMBALLO PACKAGE 400 pz	IMBALLO PACKAGE 800 pz	IMBALLO PACKAGE 640 pz	IMBALLO PACKAGE 400 pz	IMBALLO PACKAGE 800 pz	IMBALLO PACKAGE 640 pz	IMBALLO PACKAGE 400 pz

MONTAGGIO PLACCA MYLIFE® SU APPARECCHI MYLIFE® MYLIFE® COVER PLATE ASSEMBLING ON MYLIFE® DEVICES

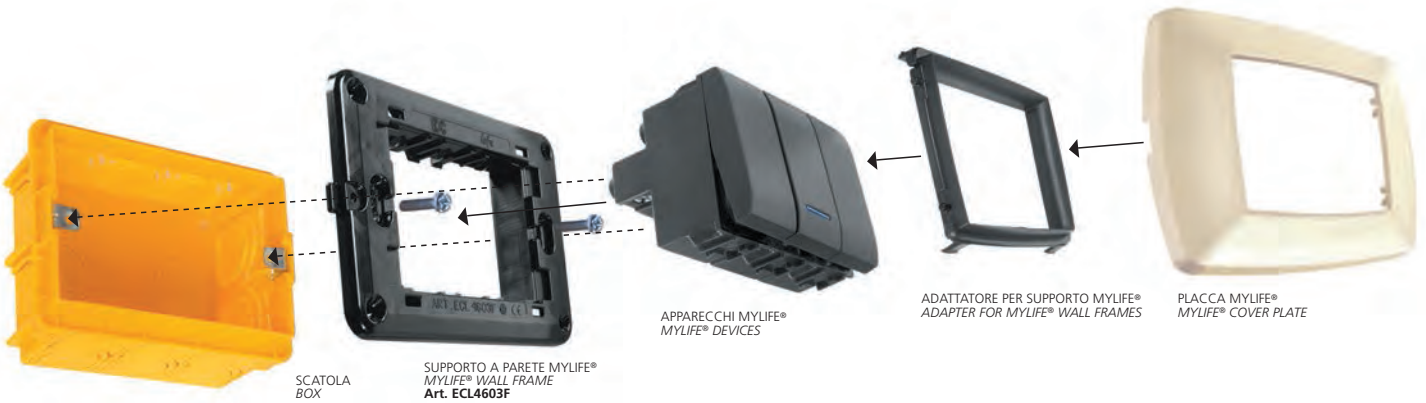

ADATTATORI PER SUPPORTI DI ALTRE SERIE CON STESSO STANDARD ADAPTERS FOR FRAMES OF OTHER SERIES WITH THE SAME STANDARD SYSTEM

 GRIGIO GREY 			 BIANCO WHITE 			 CROMO CHROME 		
ECL2980-3	ECL2980-4	ECL2980-7	ECL2980-3WH	ECL2980-4WH	ECL2980-7WH	ECL2980-3CR	ECL2980-4CR	ECL2980-7CR
								
3 MODULI MODULES	4 MODULI MODULES	7 MODULI MODULES	3 MODULI MODULES	4 MODULI MODULES	7 MODULI MODULES	3 MODULI MODULES	4 MODULI MODULES	7 MODULI MODULES
CONFEZ. BOX 50 pz	CONFEZ. BOX 40 pz	CONFEZ. BOX 25 pz	CONFEZ. BOX 50 pz	CONFEZ. BOX 40 pz	CONFEZ. BOX 25 pz	CONFEZ. BOX 50 pz	CONFEZ. BOX 40 pz	CONFEZ. BOX 25 pz
IMBALLO PACKAGE 800 pz	IMBALLO PACKAGE 640 pz	IMBALLO PACKAGE 400 pz	IMBALLO PACKAGE 800 pz	IMBALLO PACKAGE 640 pz	IMBALLO PACKAGE 400 pz	IMBALLO PACKAGE 800 pz	IMBALLO PACKAGE 640 pz	IMBALLO PACKAGE 400 pz

MONTAGGIO SU APPARECCHI DI ALTRE SERIE CON STESSO STANDARD ASSEMBLING ON OTHER SERIES DEVICES WITH THE SAME STANDARD SYSTEM

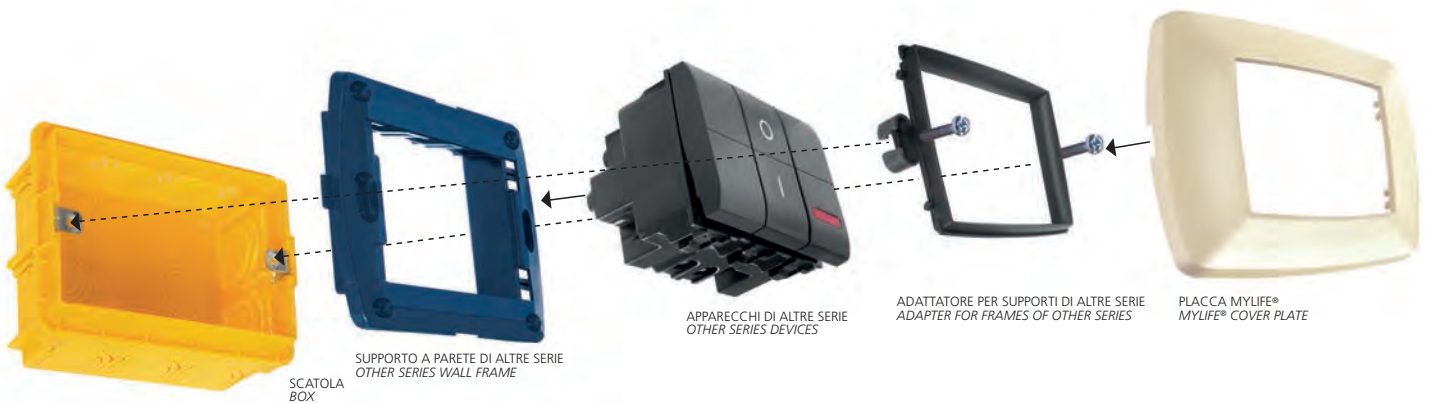

SCATOLA BOX

SUPPORTO A PARETE DI ALTRE SERIE OTHER SERIES WALL FRAME

APPARECCHI DI ALTRE SERIE OTHER SERIES DEVICES

ADATTATORE PER SUPPORTI DI ALTRE SERIE ADAPTER FOR FRAMES OF OTHER SERIES

PLACCA MYLIFE® MYLIFE® COVER PLATE

ADATTATORI PER SUPPORTI DI ALTRE SERIE CON STESSO STANDARD ADAPTERS FOR FRAMES OF OTHER SERIES WITH THE SAME STANDARD SYSTEM

 ECL2980-4B Adattatore 4 moduli 4 modules adapter 	 ECL2980-7B Adattatore 7 moduli 7 modules adapter 
CONFEZ. BOX 40 pz	CONFEZ. BOX 25 pz
IMBALLO PACKAGE 640 pz	IMBALLO PACKAGE 400 pz

MONTAGGIO SU APPARECCHI DI ALTRE SERIE CON STESSO STANDARD ASSEMBLING ON OTHER SERIES DEVICES WITH THE SAME STANDARD SYSTEM



SCATOLA BOX

SUPPORTO A PARETE DI ALTRE SERIE OTHER SERIES WALL FRAME

APPARECCHI DI ALTRE SERIE OTHER SERIES DEVICES

ADATTATORE PER SUPPORTI DI ALTRE SERIE ADAPTER FOR FRAMES OF OTHER SERIES Art. ECL2980-4B

PLACCA MYLIFE® MYLIFE® COVER PLATE

I supporti MYLIFE®-TL permettono l'utilizzo delle placche MYLIFE® con apparecchi compatibili di altre serie.
Questo tipo di supporto permette l'aggancio posteriore degli apparecchi modulari compatibili.

*MYLIFE®-TL wall frames allow the use of MYLIFE® cover plates with compatible modular devices of other series.
This type of wall frame allows the back docking of compatible modular devices.*

SUPPORTI PER APPARECCHI COMPATIBILI WALL FRAMES FOR COMPATIBLE DEVICES



ECL2980 TL

Supporto 3 moduli con viti per serie compatibili
3 modules frame with screws for compatible series

CONFEZ. BOX	25 pz
IMBALLO PACKAGE	200 pz



ECL2980 TL2

Supporto UNEL + 1 modulo con viti per serie compatibili
UNEL + 1 module frame with screws for compatible series

CONFEZ. BOX	25 pz
IMBALLO PACKAGE	200 pz



ECL2980 TL4

Supporto 4 moduli con viti per serie compatibili
4 modules frame with screws for compatible series

CONFEZ. BOX	20 pz
IMBALLO PACKAGE	160 pz



ECL2980 TL6

Supporto 6 moduli con viti per serie compatibili
6 modules frame with screws for compatible series

CONFEZ. BOX	10 pz
IMBALLO PACKAGE	80 pz



MONTAGGIO SU APPARECCHI COMPATIBILI ASSEMBLING ON COMPATIBLE DEVICES

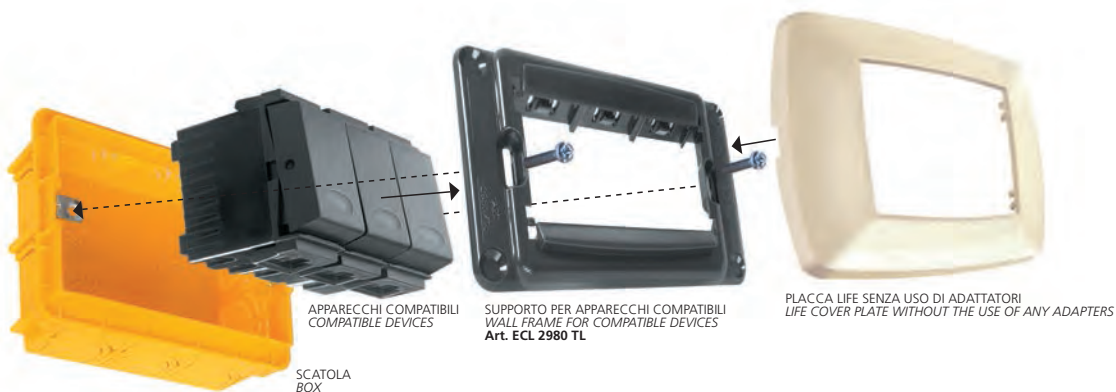

APPARECCHI COMPATIBILI
COMPATIBLE DEVICES

SUPPORTO PER APPARECCHI COMPATIBILI
WALL FRAME FOR COMPATIBLE DEVICES
Art. ECL 2980 TL

PLACCA LIFE SENZA USO DI ADATTATORI
LIFE COVER PLATE WITHOUT THE USE OF ANY ADAPTERS

SCATOLA
BOX

VERSIONI DISPONIBILI AVAILABLE MODELS



2 MODULI
2 MODULES

2x2 MODULI
2x2 MODULES

2x3 MODULI
2x3 MODULES

SUPPORTI A PARETE PER SCATOLA TONDA ED INTERNAZIONALE WALL FRAMES FOR ROUND AND INTERNATIONAL BOX



ECL4601

Supporto assemblabile internazionale
 2 moduli - scatola quadrata interasse 71 mm
 Connectable international frame
 2 modules - square box 71 mm wheelbase

CONF. BOX 40 pz
 IMBALLO PACKAGE 480 pz



ECL4602

Supporto assemblabile con zanche 2 moduli
 per scatola tonda diam. 60 mm e scatola quadrata interasse 71 mm
 Connectable international frame with staples 2 modules
 for round box diam. 60 mm and square box 71 mm wheelbase

CONF. BOX 25 pz
 IMBALLO PACKAGE 300 pz



Vista posteriore
Back side view

MONTAGGIO SU SCATOLA TONDA ASSEMBLING ON ROUND BOX

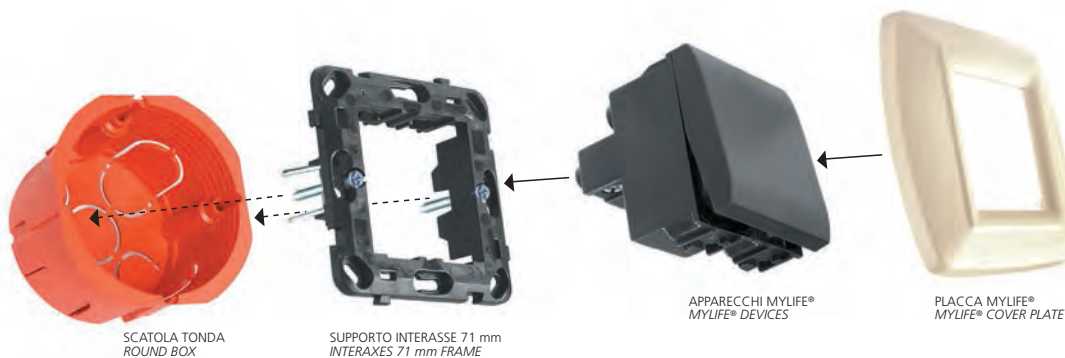

FINITURE BASE BASIC FINISHES

 <p>BIANCO WHITE CE</p> <p>ECL2982 WH ECL2974 WH ECL2976 WH</p> <p>2 MODULI MODULES 2x2 MODULI MODULES 2x3 MODULI MODULES</p> <p>CONFEZ. BOX 30 PZ CONFEZ. BOX 15 PZ CONFEZ. BOX 10 PZ</p> <p>IMBALLO PACKAGE 360 PZ IMBALLO PACKAGE 180 PZ IMBALLO PACKAGE 120 PZ</p>			 <p>AVORIO IVORY CE</p> <p>ECL2982 A ECL2974 A ECL2976 A</p> <p>2 MODULI MODULES 2x2 MODULI MODULES 2x3 MODULI MODULES</p> <p>CONFEZ. BOX 30 PZ CONFEZ. BOX 15 PZ CONFEZ. BOX 10 PZ</p> <p>IMBALLO PACKAGE 360 PZ IMBALLO PACKAGE 180 PZ IMBALLO PACKAGE 120 PZ</p>			 <p>GRIGIO SCURO DARK GREY CE</p> <p>ECL2982 GS ECL2974 GS ECL2976 GS</p> <p>2 MODULI MODULES 2x2 MODULI MODULES 2x3 MODULI MODULES</p> <p>CONFEZ. BOX 30 PZ CONFEZ. BOX 15 PZ CONFEZ. BOX 10 PZ</p> <p>IMBALLO PACKAGE 360 PZ IMBALLO PACKAGE 180 PZ IMBALLO PACKAGE 120 PZ</p>			 <p>NERO BLACK CE</p> <p>ECL2982 N ECL2974 N ECL2976 N</p> <p>2 MODULI MODULES 2x2 MODULI MODULES 2x3 MODULI MODULES</p> <p>CONFEZ. BOX 30 PZ CONFEZ. BOX 15 PZ CONFEZ. BOX 10 PZ</p> <p>IMBALLO PACKAGE 360 PZ IMBALLO PACKAGE 180 PZ IMBALLO PACKAGE 120 PZ</p>		
---	--	--	--	--	--	--	--	--	--	--	--

 <p>NERO GLITTERING GLITTERING BLACK CE</p> <p>ECL2982 NG ECL2974 NG ECL2976 NG</p> <p>2 MODULI MODULES 2x2 MODULI MODULES 2x3 MODULI MODULES</p> <p>CONFEZ. BOX 30 PZ CONFEZ. BOX 15 PZ CONFEZ. BOX 10 PZ</p> <p>IMBALLO PACKAGE 360 PZ IMBALLO PACKAGE 180 PZ IMBALLO PACKAGE 120 PZ</p>			 <p>BLU BLUE CE</p> <p>ECL2982 BL ECL2974 BL ECL2976 BL</p> <p>2 MODULI MODULES 2x2 MODULI MODULES 2x3 MODULI MODULES</p> <p>CONFEZ. BOX 30 PZ CONFEZ. BOX 15 PZ CONFEZ. BOX 10 PZ</p> <p>IMBALLO PACKAGE 360 PZ IMBALLO PACKAGE 180 PZ IMBALLO PACKAGE 120 PZ</p>			 <p>VERDE SCOZIA SCOTTISH GREEN CE</p> <p>ECL2982 VS ECL2974 VS ECL2976 VS</p> <p>2 MODULI MODULES 2x2 MODULI MODULES 2x3 MODULI MODULES</p> <p>CONFEZ. BOX 30 PZ CONFEZ. BOX 15 PZ CONFEZ. BOX 10 PZ</p> <p>IMBALLO PACKAGE 360 PZ IMBALLO PACKAGE 180 PZ IMBALLO PACKAGE 120 PZ</p>			 <p>AMARANTO BURGUNDY CE</p> <p>ECL2982 AM ECL2974 AM ECL2976 AM</p> <p>2 MODULI MODULES 2x2 MODULI MODULES 2x3 MODULI MODULES</p> <p>CONFEZ. BOX 30 PZ CONFEZ. BOX 15 PZ CONFEZ. BOX 10 PZ</p> <p>IMBALLO PACKAGE 360 PZ IMBALLO PACKAGE 180 PZ IMBALLO PACKAGE 120 PZ</p>		
---	--	--	---	--	--	---	--	--	--	--	--

FINITURE PASTELLO PASTEL FINISHES

 <p>AZZURRO PASTELLO PASTEL AZURE CE</p> <p>ECL2982 PA ECL2974 PA ECL2976 PA</p> <p>2 MODULI MODULES 2x2 MODULI MODULES 2x3 MODULI MODULES</p> <p>CONFEZ. BOX 30 PZ CONFEZ. BOX 15 PZ CONFEZ. BOX 10 PZ</p> <p>IMBALLO PACKAGE 360 PZ IMBALLO PACKAGE 180 PZ IMBALLO PACKAGE 120 PZ</p>			 <p>VERDE PASTELLO PASTEL GREEN CE</p> <p>ECL2982 PG ECL2974 PG ECL2976 PG</p> <p>2 MODULI MODULES 2x2 MODULI MODULES 2x3 MODULI MODULES</p> <p>CONFEZ. BOX 30 PZ CONFEZ. BOX 15 PZ CONFEZ. BOX 10 PZ</p> <p>IMBALLO PACKAGE 360 PZ IMBALLO PACKAGE 180 PZ IMBALLO PACKAGE 120 PZ</p>			 <p>GIALLO PASTELLO PASTEL YELLOW CE</p> <p>ECL2982 PY ECL2974 PY ECL2976 PY</p> <p>2 MODULI MODULES 2x2 MODULI MODULES 2x3 MODULI MODULES</p> <p>CONFEZ. BOX 30 PZ CONFEZ. BOX 15 PZ CONFEZ. BOX 10 PZ</p> <p>IMBALLO PACKAGE 360 PZ IMBALLO PACKAGE 180 PZ IMBALLO PACKAGE 120 PZ</p>			 <p>ARANCIO PASTELLO PASTEL ORANGE CE</p> <p>ECL2982 PO ECL2974 PO ECL2976 PO</p> <p>2 MODULI MODULES 2x2 MODULI MODULES 2x3 MODULI MODULES</p> <p>CONFEZ. BOX 30 PZ CONFEZ. BOX 15 PZ CONFEZ. BOX 10 PZ</p> <p>IMBALLO PACKAGE 360 PZ IMBALLO PACKAGE 180 PZ IMBALLO PACKAGE 120 PZ</p>		
--	--	--	--	--	--	---	--	--	---	--	--

FINITURE METALLICHE METALLIC FINISHES

 <p>ALLUMINIO CHIARO LIGHT ALUMINIUM CE</p> <p>ECL2982 AC ECL2974 AC ECL2976 AC</p> <p>2 MODULI MODULES 2x2 MODULI MODULES 2x3 MODULI MODULES</p> <p>CONFEZ. BOX 30 PZ CONFEZ. BOX 15 PZ CONFEZ. BOX 10 PZ</p> <p>IMBALLO PACKAGE 360 PZ IMBALLO PACKAGE 180 PZ IMBALLO PACKAGE 120 PZ</p>			 <p>ALLUMINIO NOTTE DARK ALUMINIUM CE</p> <p>ECL2982 AN ECL2974 AN ECL2976 AN</p> <p>2 MODULI MODULES 2x2 MODULI MODULES 2x3 MODULI MODULES</p> <p>CONFEZ. BOX 30 PZ CONFEZ. BOX 15 PZ CONFEZ. BOX 10 PZ</p> <p>IMBALLO PACKAGE 360 PZ IMBALLO PACKAGE 180 PZ IMBALLO PACKAGE 120 PZ</p>			 <p>RAME COPPER CE</p> <p>ECL2982 RM ECL2974 RM ECL2976 RM</p> <p>2 MODULI MODULES 2x2 MODULI MODULES 2x3 MODULI MODULES</p> <p>CONFEZ. BOX 30 PZ CONFEZ. BOX 15 PZ CONFEZ. BOX 10 PZ</p> <p>IMBALLO PACKAGE 360 PZ IMBALLO PACKAGE 180 PZ IMBALLO PACKAGE 120 PZ</p>			 <p>ACCIAIO SATINATO SATIN STEEL CE</p> <p>ECL2982 AS ECL2974 AS ECL2976 AS</p> <p>2 MODULI MODULES 2x2 MODULI MODULES 2x3 MODULI MODULES</p> <p>CONFEZ. BOX 30 PZ CONFEZ. BOX 15 PZ CONFEZ. BOX 10 PZ</p> <p>IMBALLO PACKAGE 360 PZ IMBALLO PACKAGE 180 PZ IMBALLO PACKAGE 120 PZ</p>		
---	--	--	---	--	--	---	--	--	---	--	--

FINITURE METALLICHE METALLIC FINISHES

 <p>METAL BLACK </p>			 <p>CROMO CHROME </p>			 <p>ORO GOLD * </p>		
ECL2982 MB	ECL2974 MB	ECL2976 MB	ECL2982 CR	ECL2974 CR	ECL2976 CR	ECL2982 OR	ECL2974 OR	ECL2976 OR
								
2 MODULI MODULES	2x2 MODULI MODULES	2x3 MODULI MODULES	2 MODULI MODULES	2x2 MODULI MODULES	2x3 MODULI MODULES	2 MODULI MODULES	2x2 MODULI MODULES	2x3 MODULI MODULES
CONF. BOX 30 pz	CONF. BOX 15 pz	CONF. BOX 10 pz	CONF. BOX 30 pz	CONF. BOX 15 pz	CONF. BOX 10 pz	CONF. BOX 30 pz	CONF. BOX 15 pz	CONF. BOX 10 pz
IMBALLO PACKAGE 360 pz	IMBALLO PACKAGE 180 pz	IMBALLO PACKAGE 120 pz	IMBALLO PACKAGE 360 pz	IMBALLO PACKAGE 180 pz	IMBALLO PACKAGE 120 pz	IMBALLO PACKAGE 360 pz	IMBALLO PACKAGE 180 pz	IMBALLO PACKAGE 120 pz

* Realizzata con bagno galvanico in oro 24 kt
 Galvanic coating with 24 kt gold

FINITURE VULCANIZZATE VULCANISED FINISHES

 <p>GRIGIO NOTTE DARK GREY </p>			 <p>GRIGIO CHIARO LIGHT GREY </p>			 <p>CARTA DA ZUCCHERO LIGHT BLUE </p>			 <p>VERDE NOTTE DARK GREEN </p>		
ECL2982 V-GN	ECL2974 V-GN	ECL2976 V-GN	ECL2982 V-GC	ECL2974 V-GC	ECL2976 V-GC	ECL2982 V-CZ	ECL2974 V-CZ	ECL2976 V-CZ	ECL2982 V-VN	ECL2974 V-VN	ECL2976 V-VN
											
2 MODULI MODULES	2x2 MODULI MODULES	2x3 MODULI MODULES	2 MODULI MODULES	2x2 MODULI MODULES	2x3 MODULI MODULES	2 MODULI MODULES	2x2 MODULI MODULES	2x3 MODULI MODULES	2 MODULI MODULES	2x2 MODULI MODULES	2x3 MODULI MODULES
CONF. BOX 30 pz	CONF. BOX 15 pz	CONF. BOX 10 pz	CONF. BOX 30 pz	CONF. BOX 15 pz	CONF. BOX 10 pz	CONF. BOX 30 pz	CONF. BOX 15 pz	CONF. BOX 10 pz	CONF. BOX 30 pz	CONF. BOX 15 pz	CONF. BOX 10 pz
IMBALLO PACKAGE 360 pz	IMBALLO PACKAGE 180 pz	IMBALLO PACKAGE 120 pz	IMBALLO PACKAGE 360 pz	IMBALLO PACKAGE 180 pz	IMBALLO PACKAGE 120 pz	IMBALLO PACKAGE 360 pz	IMBALLO PACKAGE 180 pz	IMBALLO PACKAGE 120 pz	IMBALLO PACKAGE 360 pz	IMBALLO PACKAGE 180 pz	IMBALLO PACKAGE 120 pz

 <p>ARAGOSTA LOBSTER RED </p>		
ECL2982 V-AR	ECL2974 V-AR	ECL2976 V-AR
		
2 MODULI MODULES	2x2 MODULI MODULES	2x3 MODULI MODULES
CONF. BOX 30 pz	CONF. BOX 15 pz	CONF. BOX 10 pz
IMBALLO PACKAGE 360 pz	IMBALLO PACKAGE 180 pz	IMBALLO PACKAGE 120 pz

FINITURE LEGNO WOODEN-LIKE FINISHES

 <p>BETULLA BIRCH </p>			 <p>LEGNO CHIARO LIGHT WOOD </p>			 <p>LEGNO SCURO DARK WOOD </p>			 <p>WENGÈ </p>		
ECL2982 BT	ECL2974 BT	ECL2976 BT	ECL2982 LC	ECL2974 LC	ECL2976 LC	ECL2982 LS	ECL2974 LS	ECL2976 LS	ECL2982 WG	ECL2974 WG	ECL2976 WG
											
2 MODULI MODULES	2x2 MODULI MODULES	2x3 MODULI MODULES	2 MODULI MODULES	2x2 MODULI MODULES	2x3 MODULI MODULES	2 MODULI MODULES	2x2 MODULI MODULES	2x3 MODULI MODULES	2 MODULI MODULES	2x2 MODULI MODULES	2x3 MODULI MODULES
CONF. BOX 30 pz	CONF. BOX 15 pz	CONF. BOX 10 pz	CONF. BOX 30 pz	CONF. BOX 15 pz	CONF. BOX 10 pz	CONF. BOX 30 pz	CONF. BOX 15 pz	CONF. BOX 10 pz	CONF. BOX 30 pz	CONF. BOX 15 pz	CONF. BOX 10 pz
IMBALLO PACKAGE 360 pz	IMBALLO PACKAGE 180 pz	IMBALLO PACKAGE 120 pz	IMBALLO PACKAGE 360 pz	IMBALLO PACKAGE 180 pz	IMBALLO PACKAGE 120 pz	IMBALLO PACKAGE 360 pz	IMBALLO PACKAGE 180 pz	IMBALLO PACKAGE 120 pz	IMBALLO PACKAGE 360 pz	IMBALLO PACKAGE 180 pz	IMBALLO PACKAGE 120 pz

VERSIONI DISPONIBILI AVAILABLE MODELS



1 MODULO 1 MODULE



2 MODULI 2 MODULES



3 MODULI 3 MODULES

La placca MYLIFE® ECO risponde alle nuove esigenze nell'ambito del residenziale di base e dell'edilizia pubblica.

L'estrema praticità del sistema di fissaggio, il design moderno e l'installazione sulla serie civile MYLIFE® la rendono la soluzione ottimale per chi non vuole rinunciare all'estetica e al design, pur contenendo i costi.

MYLIFE® ECO cover plates answer to new trends in range of basic residential and public building.

Easy fastening system, modern design and assembling on MYLIFE® electrical devices, make it the better solution for who doesn't want renounce to design and beauty, with contained prices.

PLACCHE COPRINTERRUTTORI COVER PLATES



BIANCO WHITE **CE**

ECL2961 WH ECL2962 WH ECL2963 WH



1 MODULO MODULE 2 MODULI MODULES 3 MODULI MODULES

CONFEZ. BOX 20 pz CONFEZ. BOX 20 pz CONFEZ. BOX 20 pz

IMBALLO PACKAGE 240 pz IMBALLO PACKAGE 240 pz IMBALLO PACKAGE 240 pz



AVORIO IVORY **CE**

ECL2961 A ECL2962 A ECL2963 A



1 MODULO MODULE 2 MODULI MODULES 3 MODULI MODULES

CONFEZ. BOX 20 pz CONFEZ. BOX 20 pz CONFEZ. BOX 20 pz

IMBALLO PACKAGE 240 pz IMBALLO PACKAGE 240 pz IMBALLO PACKAGE 240 pz



NERO BLACK **CE**

ECL2961 N ECL2962 N ECL2963 N



1 MODULO MODULE 2 MODULI MODULES 3 MODULI MODULES

CONFEZ. BOX 20 pz CONFEZ. BOX 20 pz CONFEZ. BOX 20 pz

IMBALLO PACKAGE 240 pz IMBALLO PACKAGE 240 pz IMBALLO PACKAGE 240 pz

MONTAGGIO PLACCA MYLIFE® ECO SU APPARECCHI MYLIFE® MYLIFE® ECO COVER PLATE ASSEMBLING ON MYLIFE® DEVICES

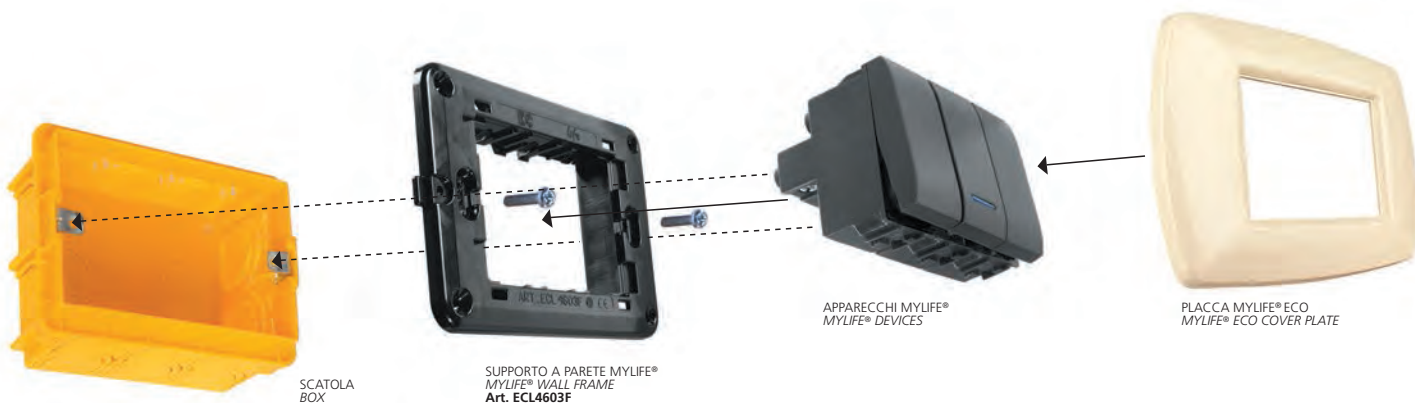





my life Q[®]

Placche coprinterruttori

MYLIFE Q[®] è l'ultima nata tra le nostre placche coprinterruttori in tecnopolimero ma è già la più affermata per il suo stile contemporaneo fatto di linee fluide e per la sua versatilità e praticità in quanto si installa in pochi istanti in abbinamento agli apparecchi MYLIFE[®] senza necessità di utilizzare alcun adattatore.

MYLIFE Q[®] è disponibile in una gamma di 23 colori in 6 finiture differenti bilanciate per esaltare ogni architettura degli interni ed assecondare qualsiasi mood.

Cover plates

MYLIFE Q[®] is last born among our cover plates in technopolymer but is already the most prominent for its contemporary style, made of flowing lines, and for its versatility and practicality: its assembly is very easy, in mach for MYLIFE[®] modular devices, without using any adapters.

MYLIFE Q[®] is available in 23 colours with 6 different finishes, created to exalt every architectural style and appease any mood.



VERSIONI DISPONIBILI AVAILABLE MODELS



2 MODULI 2 MODULES



3 MODULI 3 MODULES



4 MODULI 4 MODULES



7 MODULI 7 MODULES

Per la pulizia delle placche MYLIFE Q® "FINITURE METALLICHE" utilizzare esclusivamente un panno asciutto senza aggiunta di nessun tipo di solvente (spray, ecc..), che potrebbe alterarne i colori. Le foto hanno puramente carattere di presentazione

To clean MYLIFE Q® "METALLIC FINISHES" cover plates, use only a dry cloth without add any type of cleaning solvent that could alter its original colour. Cover plates pictures have only a presentation purpose.

FINITURE BASE BASIC FINISHES



BIANCO WHITE



AVORIO IVORY



GRIGIO SCURO DARK GREY



ECL2882 WH	ECL2883 WH	ECL2884 WH	ECL2887 WH
2 MODULI MODULES	3 MODULI MODULES	4 MODULI MODULES	7 MODULI MODULES
CONFEZ. BOX 30 pz	CONFEZ. BOX 20 pz	CONFEZ. BOX 15 pz	CONFEZ. BOX 10 pz
IMBALLO PACKAGE 360 pz	IMBALLO PACKAGE 240 pz	IMBALLO PACKAGE 180 pz	IMBALLO PACKAGE 120 pz

ECL2882 A	ECL2883 A	ECL2884 A	ECL2887 A
2 MODULI MODULES	3 MODULI MODULES	4 MODULI MODULES	7 MODULI MODULES
CONFEZ. BOX 30 pz	CONFEZ. BOX 20 pz	CONFEZ. BOX 15 pz	CONFEZ. BOX 10 pz
IMBALLO PACKAGE 360 pz	IMBALLO PACKAGE 240 pz	IMBALLO PACKAGE 180 pz	IMBALLO PACKAGE 120 pz

ECL2882 GS	ECL2883 GS	ECL2884 GS	ECL2887 GS
2 MODULI MODULES	3 MODULI MODULES	4 MODULI MODULES	7 MODULI MODULES
CONFEZ. BOX 30 pz	CONFEZ. BOX 20 pz	CONFEZ. BOX 15 pz	CONFEZ. BOX 10 pz
IMBALLO PACKAGE 360 pz	IMBALLO PACKAGE 240 pz	IMBALLO PACKAGE 180 pz	IMBALLO PACKAGE 120 pz



NERO BLACK



NERO GLITTERING GLITTERING BLACK



BLU BLUE



ECL2882 N	ECL2883 N	ECL2884 N	ECL2887 N
2 MODULI MODULES	3 MODULI MODULES	4 MODULI MODULES	7 MODULI MODULES
CONFEZ. BOX 30 pz	CONFEZ. BOX 20 pz	CONFEZ. BOX 15 pz	CONFEZ. BOX 10 pz
IMBALLO PACKAGE 360 pz	IMBALLO PACKAGE 240 pz	IMBALLO PACKAGE 180 pz	IMBALLO PACKAGE 120 pz

ECL2882 NG	ECL2883 NG	ECL2884 NG	ECL2887 NG
2 MODULI MODULES	3 MODULI MODULES	4 MODULI MODULES	7 MODULI MODULES
CONFEZ. BOX 30 pz	CONFEZ. BOX 20 pz	CONFEZ. BOX 15 pz	CONFEZ. BOX 10 pz
IMBALLO PACKAGE 360 pz	IMBALLO PACKAGE 240 pz	IMBALLO PACKAGE 180 pz	IMBALLO PACKAGE 120 pz

ECL2882 BL	ECL2883 BL	ECL2884 BL	ECL2887 BL
2 MODULI MODULES	3 MODULI MODULES	4 MODULI MODULES	7 MODULI MODULES
CONFEZ. BOX 30 pz	CONFEZ. BOX 20 pz	CONFEZ. BOX 15 pz	CONFEZ. BOX 10 pz
IMBALLO PACKAGE 360 pz	IMBALLO PACKAGE 240 pz	IMBALLO PACKAGE 180 pz	IMBALLO PACKAGE 120 pz



AMARANTO BURGUNDY



ECL2882 AM ECL2883 AM ECL2884 AM ECL2887 AM



2 MODULI MODULES	3 MODULI MODULES	4 MODULI MODULES	7 MODULI MODULES
CONFEZ. BOX 30 pz	CONFEZ. BOX 20 pz	CONFEZ. BOX 15 pz	CONFEZ. BOX 10 pz
IMBALLO PACKAGE 360 pz	IMBALLO PACKAGE 240 pz	IMBALLO PACKAGE 180 pz	IMBALLO PACKAGE 120 pz

FINITURE PASTELLO PASTEL FINISHES



GIALLO PASTELLO PASTEL YELLOW



ECL2882 PY ECL2883 PY ECL2884 PY ECL2887 PY



2 MODULI MODULES	3 MODULI MODULES	4 MODULI MODULES	7 MODULI MODULES
CONFEZ. BOX 30 pz	CONFEZ. BOX 20 pz	CONFEZ. BOX 15 pz	CONFEZ. BOX 10 pz
IMBALLO PACKAGE 360 pz	IMBALLO PACKAGE 240 pz	IMBALLO PACKAGE 180 pz	IMBALLO PACKAGE 120 pz

FINITURE METALLICHE METALLIC FINISHES

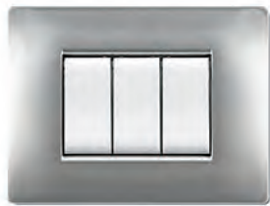

ALLUMINIO CHIARO LIGHT ALUMINIUM



ECL2882 AC ECL2883 AC ECL2884 AC ECL2887 AC



2 MODULI MODULES	3 MODULI MODULES	4 MODULI MODULES	7 MODULI MODULES
CONFEZ. BOX 30 pz	CONFEZ. BOX 20 pz	CONFEZ. BOX 15 pz	CONFEZ. BOX 10 pz
IMBALLO PACKAGE 360 pz	IMBALLO PACKAGE 240 pz	IMBALLO PACKAGE 180 pz	IMBALLO PACKAGE 120 pz



ALLUMINIO NOTTE DARK ALUMINIUM



ECL2882 AN ECL2883 AN ECL2884 AN ECL2887 AN



2 MODULI MODULES	3 MODULI MODULES	4 MODULI MODULES	7 MODULI MODULES
CONFEZ. BOX 30 pz	CONFEZ. BOX 20 pz	CONFEZ. BOX 15 pz	CONFEZ. BOX 10 pz
IMBALLO PACKAGE 360 pz	IMBALLO PACKAGE 240 pz	IMBALLO PACKAGE 180 pz	IMBALLO PACKAGE 120 pz



ACCIAIO SATINATO SATIN STEEL



ECL2882 AS ECL2883 AS ECL2884 AS ECL2887 AS



2 MODULI MODULES	3 MODULI MODULES	4 MODULI MODULES	7 MODULI MODULES
CONFEZ. BOX 30 pz	CONFEZ. BOX 20 pz	CONFEZ. BOX 15 pz	CONFEZ. BOX 10 pz
IMBALLO PACKAGE 360 pz	IMBALLO PACKAGE 240 pz	IMBALLO PACKAGE 180 pz	IMBALLO PACKAGE 120 pz



METAL BLACK



ECL2882 MB ECL2883 MB ECL2884 MB ECL2887 MB



2 MODULI MODULES	3 MODULI MODULES	4 MODULI MODULES	7 MODULI MODULES
CONFEZ. BOX 30 pz	CONFEZ. BOX 20 pz	CONFEZ. BOX 15 pz	CONFEZ. BOX 10 pz
IMBALLO PACKAGE 360 pz	IMBALLO PACKAGE 240 pz	IMBALLO PACKAGE 180 pz	IMBALLO PACKAGE 120 pz



CROMO CHROME



ECL2882 CR ECL2883 CR ECL2884 CR ECL2887 CR



2 MODULI MODULES	3 MODULI MODULES	4 MODULI MODULES	7 MODULI MODULES
CONFEZ. BOX 30 pz	CONFEZ. BOX 20 pz	CONFEZ. BOX 15 pz	CONFEZ. BOX 10 pz
IMBALLO PACKAGE 360 pz	IMBALLO PACKAGE 240 pz	IMBALLO PACKAGE 180 pz	IMBALLO PACKAGE 120 pz



ORO GOLD *



ECL2882 OR ECL2883 OR ECL2884 OR ECL2887 OR



2 MODULI MODULES	3 MODULI MODULES	4 MODULI MODULES	7 MODULI MODULES
CONFEZ. BOX 30 pz	CONFEZ. BOX 20 pz	CONFEZ. BOX 15 pz	CONFEZ. BOX 10 pz
IMBALLO PACKAGE 360 pz	IMBALLO PACKAGE 240 pz	IMBALLO PACKAGE 180 pz	IMBALLO PACKAGE 120 pz

* Realizzata con bagno galvanico in oro 24 kt. Galvanic coating with 24 kt gold

FINITURE VULCANIZZATE VULCANISED FINISHES



GRIGIO NOTTE DARK GREY



ECL2882 V-GN	ECL2883 V-GN	ECL2884 V-GN	ECL2887 V-GN
2 MODULI MODULES	3 MODULI MODULES	4 MODULI MODULES	7 MODULI MODULES
CONFEZ. BOX 30 pz	CONFEZ. BOX 20 pz	CONFEZ. BOX 15 pz	CONFEZ. BOX 10 pz
IMBALLO PACKAGE 360 pz	IMBALLO PACKAGE 240 pz	IMBALLO PACKAGE 180 pz	IMBALLO PACKAGE 120 pz



GRIGIO CHIARO LIGHT GREY



ECL2882 V-GC	ECL2883 V-GC	ECL2884 V-GC	ECL2887 V-GC
2 MODULI MODULES	3 MODULI MODULES	4 MODULI MODULES	7 MODULI MODULES
CONFEZ. BOX 30 pz	CONFEZ. BOX 20 pz	CONFEZ. BOX 15 pz	CONFEZ. BOX 10 pz
IMBALLO PACKAGE 360 pz	IMBALLO PACKAGE 240 pz	IMBALLO PACKAGE 180 pz	IMBALLO PACKAGE 120 pz

FINITURE LEGNO WOODEN-LIKE FINISHES



BETULLA BIRCH



ECL2882 BT	ECL2883 BT	ECL2884 BT	ECL2887 BT
2 MODULI MODULES	3 MODULI MODULES	4 MODULI MODULES	7 MODULI MODULES
CONFEZ. BOX 30 pz	CONFEZ. BOX 20 pz	CONFEZ. BOX 15 pz	CONFEZ. BOX 10 pz
IMBALLO PACKAGE 360 pz	IMBALLO PACKAGE 240 pz	IMBALLO PACKAGE 180 pz	IMBALLO PACKAGE 120 pz



LEGNO CHIARO LIGHT WOOD



ECL2882 LC	ECL2883 LC	ECL2884 LC	ECL2887 LC
2 MODULI MODULES	3 MODULI MODULES	4 MODULI MODULES	7 MODULI MODULES
CONFEZ. BOX 30 pz	CONFEZ. BOX 20 pz	CONFEZ. BOX 15 pz	CONFEZ. BOX 10 pz
IMBALLO PACKAGE 360 pz	IMBALLO PACKAGE 240 pz	IMBALLO PACKAGE 180 pz	IMBALLO PACKAGE 120 pz



LEGNO SCURO DARK WOOD



ECL2882 LS	ECL2883 LS	ECL2884 LS	ECL2887 LS
2 MODULI MODULES	3 MODULI MODULES	4 MODULI MODULES	7 MODULI MODULES
CONFEZ. BOX 30 pz	CONFEZ. BOX 20 pz	CONFEZ. BOX 15 pz	CONFEZ. BOX 10 pz
IMBALLO PACKAGE 360 pz	IMBALLO PACKAGE 240 pz	IMBALLO PACKAGE 180 pz	IMBALLO PACKAGE 120 pz



RADICA BURL WOOD



ECL2882 RA	ECL2883 RA	ECL2884 RA	ECL2887 RA
2 MODULI MODULES	3 MODULI MODULES	4 MODULI MODULES	7 MODULI MODULES
CONFEZ. BOX 30 pz	CONFEZ. BOX 20 pz	CONFEZ. BOX 15 pz	CONFEZ. BOX 10 pz
IMBALLO PACKAGE 360 pz	IMBALLO PACKAGE 240 pz	IMBALLO PACKAGE 180 pz	IMBALLO PACKAGE 120 pz



WENGÈ



ECL2882 WG	ECL2883 WG	ECL2884 WG	ECL2887 WG
2 MODULI MODULES	3 MODULI MODULES	4 MODULI MODULES	7 MODULI MODULES
CONFEZ. BOX 30 pz	CONFEZ. BOX 20 pz	CONFEZ. BOX 15 pz	CONFEZ. BOX 10 pz
IMBALLO PACKAGE 360 pz	IMBALLO PACKAGE 240 pz	IMBALLO PACKAGE 180 pz	IMBALLO PACKAGE 120 pz

FINITURE ESCLUSIVE EXCLUSIVE FINISHES



SABBIA ORO GOLD SAND



ECL2882 SO	ECL2883 SO	ECL2884 SO	ECL2887 SO
2 MODULI MODULES	3 MODULI MODULES	4 MODULI MODULES	7 MODULI MODULES
CONFEZ. BOX 30 pz	CONFEZ. BOX 20 pz	CONFEZ. BOX 15 pz	CONFEZ. BOX 10 pz
IMBALLO PACKAGE 360 pz	IMBALLO PACKAGE 240 pz	IMBALLO PACKAGE 180 pz	IMBALLO PACKAGE 120 pz



NERO OPACO MAT BLACK



ECL2882 NO	ECL2883 NO	ECL2884 NO	ECL2887 NO
2 MODULI MODULES	3 MODULI MODULES	4 MODULI MODULES	7 MODULI MODULES
CONFEZ. BOX 30 pz	CONFEZ. BOX 20 pz	CONFEZ. BOX 15 pz	CONFEZ. BOX 10 pz
IMBALLO PACKAGE 360 pz	IMBALLO PACKAGE 240 pz	IMBALLO PACKAGE 180 pz	IMBALLO PACKAGE 120 pz

ADATTATORI PER SUPPORTI DI ALTRE SERIE CON STESSO STANDARD ADAPTERS FOR FRAMES OF OTHER SERIES WITH THE SAME STANDARD SYSTEM

Gli adattatori MYLIFE Q® permettono di fissare le placche MYLIFE Q® ai supporti a parete di altre serie con lo stesso standard. L'adattatore MYLIFE Q® è composto da due parti che si montano sul retro della placca seguendo una semplicissima procedura. Esiste un adattatore specifico per ciascuna delle 4 versioni disponibili di placca MYLIFE Q®. L'adattatore MYLIFE Q® non è fornito di serie con la placca MYLIFE Q®, ma deve essere acquistato specificatamente in base all'utilizzo desiderato della placca.

MYLIFE Q® adapters allow MYLIFE Q® cover plates be fixed on frames of other series with the same standard system. MYLIFE Q® adapter is composed by 2 pieces that should be mounted on cover plate back side following a simple procedure. There is a specific adapter for each 4 available models of MYLIFE Q® cover plate. MYLIFE Q® adapter is not supplied with MYLIFE Q® cover plate, but it should be bought depending on required application of cover plate.



MONTAGGIO DEGLI ADATTATORI SULLE PLACCHE MYLIFE Q® ADAPTERS INSTALLATION ON MYLIFE Q® COVER PLATES

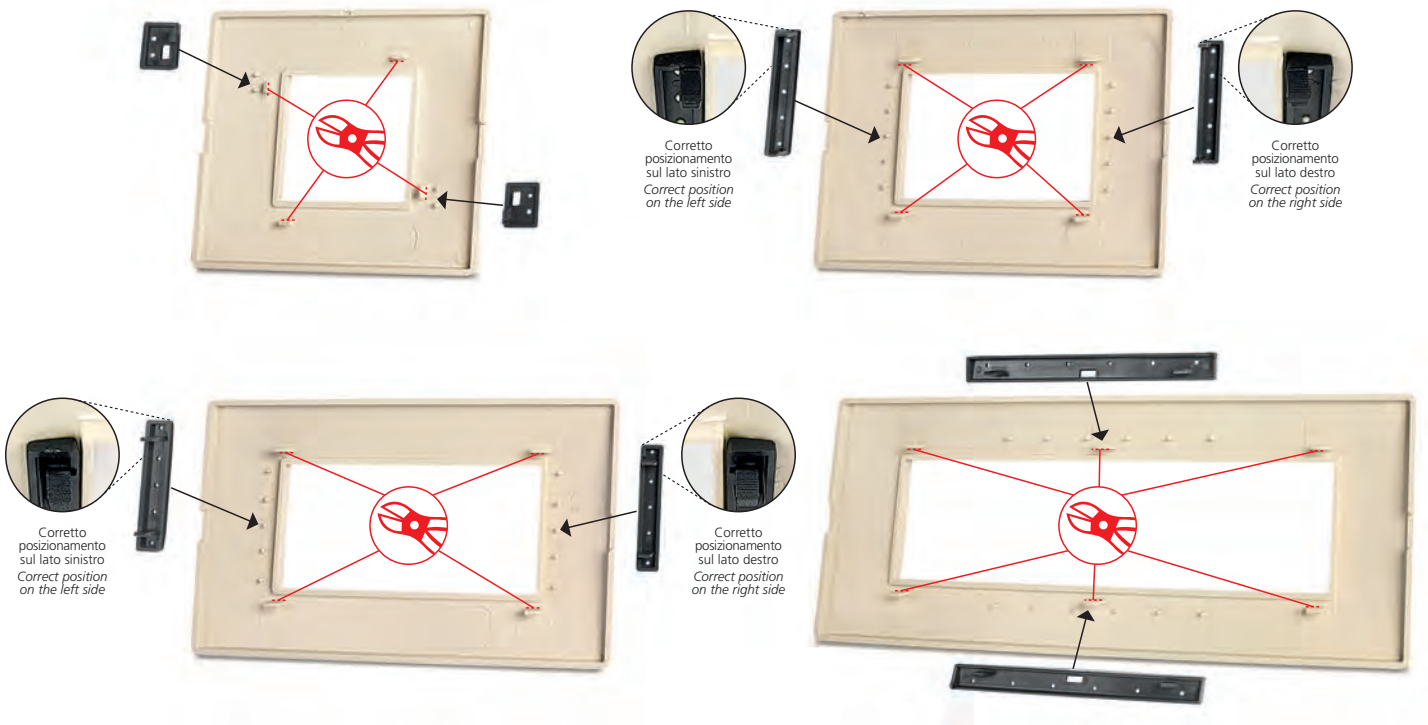

MONTAGGIO SU APPARECCHI DI ALTRE SERIE CON STESSO STANDARD ASSEMBLING ON OTHER SERIES DEVICES WITH THE SAME STANDARD SYSTEM





new PRESTIGE®

Placche coprinterruttori

Il bello si svincola del superfluo ed assume una forma essenziale, sublime, unica.

È il design elegantissimo ed attuale della nuova linea di placche coprinterruttore NEW PRESTIGE®: ben 38 colori e 6 finiture abbinabili agli apparecchi MYLIFE®.

Un sistema flessibile che permette molteplici e creative combinazioni tecniche ed estetiche che si integrano in ogni tipo di ambiente valorizzandolo oltre ogni aspettativa.

Cover plates

Beauty frees itself from unnecessary and expresses itself in a terse, sublime, unique form.

It is very fine and fashionable design of NEW PRESTIGE®, the new cover plate series: 38 colours and 6 finishes that go well together with MYLIFE® devices.

A flexible system that allows multiple and creative combining as technique as aesthetic that integrate in each type of places, enhancing them beyond expectation.



NEW PRESTIGE® PLACCHE COPRINTERRUTTORI NEW PRESTIGE® COVER PLATES

VERSIONI DISPONIBILI AVAILABLE MODELS



3 MODULI 3 MODULES



4 MODULI 4 MODULES



7 MODULI 7 MODULES

Ogni placca NEW PRESTIGE® viene fornita con la cornice cromata. È possibile sostituire la cornice fornita di serie acquistando separatamente le cornici nelle altre finiture disponibili (bianca e grigia).

Each NEW PRESTIGE® cover plate is supplied with chrome frame. It is possible to change the supplied frame buying separately the other available finishes of frames (white and grey).

Per la pulizia delle placche NEW PRESTIGE® "FINITURE METALLICHE" utilizzare esclusivamente un panno asciutto senza aggiunta di nessun tipo di solvente (spray, ecc.), che potrebbe alterarne i colori.

To clean NEW PRESTIGE® "METALLIC FINISHES" cover plates, use only a dry cloth without add any type of cleaning solvent that could alter its original colour.

FINITURE BASE BASIC FINISHES



BIANCO WHITE

ECL3083 WH	ECL3084 WH	ECL3087 WH
3 MODULI MODULES	4 MODULI MODULES	7 MODULI MODULES
CONFEZ. BOX	CONFEZ. BOX	CONFEZ. BOX
10 pz	5 pz	5 pz
IMBALLO PACKAGE	IMBALLO PACKAGE	IMBALLO PACKAGE
210 pz	105 pz	60 pz



AVORIO IVORY

ECL3083 A	ECL3084 A	ECL3087 A
3 MODULI MODULES	4 MODULI MODULES	7 MODULI MODULES
CONFEZ. BOX	CONFEZ. BOX	CONFEZ. BOX
10 pz	5 pz	5 pz
IMBALLO PACKAGE	IMBALLO PACKAGE	IMBALLO PACKAGE
210 pz	105 pz	60 pz



GRIGIO SCURO DARK GREY

ECL3083 GS	ECL3084 GS	ECL3087 GS
3 MODULI MODULES	4 MODULI MODULES	7 MODULI MODULES
CONFEZ. BOX	CONFEZ. BOX	CONFEZ. BOX
10 pz	5 pz	5 pz
IMBALLO PACKAGE	IMBALLO PACKAGE	IMBALLO PACKAGE
210 pz	105 pz	60 pz



NERO BLACK

ECL3083 N	ECL3084 N	ECL3087 N
3 MODULI MODULES	4 MODULI MODULES	7 MODULI MODULES
CONFEZ. BOX	CONFEZ. BOX	CONFEZ. BOX
10 pz	5 pz	5 pz
IMBALLO PACKAGE	IMBALLO PACKAGE	IMBALLO PACKAGE
210 pz	105 pz	60 pz



NERO GLITTERING GLITTERING BLACK

ECL3083 NG	ECL3084 NG	ECL3087 NG
3 MODULI MODULES	4 MODULI MODULES	7 MODULI MODULES
CONFEZ. BOX	CONFEZ. BOX	CONFEZ. BOX
10 pz	5 pz	5 pz
IMBALLO PACKAGE	IMBALLO PACKAGE	IMBALLO PACKAGE
210 pz	105 pz	60 pz



BLU BLUE

ECL3083 BL	ECL3084 BL	ECL3087 BL
3 MODULI MODULES	4 MODULI MODULES	7 MODULI MODULES
CONFEZ. BOX	CONFEZ. BOX	CONFEZ. BOX
10 pz	5 pz	5 pz
IMBALLO PACKAGE	IMBALLO PACKAGE	IMBALLO PACKAGE
210 pz	105 pz	60 pz



VERDE SCOZIA SCOTTISH GREEN

ECL3083 VS	ECL3084 VS	ECL3087 VS
3 MODULI MODULES	4 MODULI MODULES	7 MODULI MODULES
CONFEZ. BOX	CONFEZ. BOX	CONFEZ. BOX
10 pz	5 pz	5 pz
IMBALLO PACKAGE	IMBALLO PACKAGE	IMBALLO PACKAGE
210 pz	105 pz	60 pz





AMARANTO BURGUNDY



ECL3083 AM	ECL3084 AM	ECL3087 AM
3 MODULI MODULES	4 MODULI MODULES	7 MODULI MODULES
CONFEZ. BOX	CONFEZ. BOX	CONFEZ. BOX
10 pz	5 pz	5 pz
IMBALLO PACKAGE	IMBALLO PACKAGE	IMBALLO PACKAGE
210 pz	105 pz	60 pz

FINITURE PASTELLO PASTEL FINISHES





AZZURRO PASTELLO PASTEL AZURE **CE**
ECL3083 PA ECL3084 PA ECL3087 PA
  
3 MODULI MODULES 4 MODULI MODULES 7 MODULI MODULES
CONF. CONF. CONF.
BOX BOX BOX
 10 pz 5 pz 5 pz
IMBALLO IMBALLO IMBALLO
PACKAGE PACKAGE PACKAGE
 210 pz 105 pz 60 pz





VERDE PASTELLO PASTEL GREEN **CE**
ECL3083 PG ECL3084 PG ECL3087 PG
  
3 MODULI MODULES 4 MODULI MODULES 7 MODULI MODULES
CONF. CONF. CONF.
BOX BOX BOX
 10 pz 5 pz 5 pz
IMBALLO IMBALLO IMBALLO
PACKAGE PACKAGE PACKAGE
 210 pz 105 pz 60 pz





GIALLO PASTELLO PASTEL YELLOW **CE**
ECL3083 PY ECL3084 PY ECL3087 PY
  
3 MODULI MODULES 4 MODULI MODULES 7 MODULI MODULES
CONF. CONF. CONF.
BOX BOX BOX
 10 pz 5 pz 5 pz
IMBALLO IMBALLO IMBALLO
PACKAGE PACKAGE PACKAGE
 210 pz 105 pz 60 pz





ARANCIO PASTELLO PASTEL ORANGE **CE**
ECL3083 PO ECL3084 PO ECL3087 PO
  
3 MODULI MODULES 4 MODULI MODULES 7 MODULI MODULES
CONF. CONF. CONF.
BOX BOX BOX
 10 pz 5 pz 5 pz
IMBALLO IMBALLO IMBALLO
PACKAGE PACKAGE PACKAGE
 210 pz 105 pz 60 pz

FINITURE METALLICHE METALLIC FINISHES





ALLUMINIO CHIARO LIGHT ALUMINIUM **CE**
ECL3083 AC ECL3084 AC ECL3087 AC
  
3 MODULI MODULES 4 MODULI MODULES 7 MODULI MODULES
CONF. CONF. CONF.
BOX BOX BOX
 10 pz 5 pz 5 pz
IMBALLO IMBALLO IMBALLO
PACKAGE PACKAGE PACKAGE
 210 pz 105 pz 60 pz





ALLUMINIO NOTTE DARK ALUMINIUM **CE**
ECL3083 AN ECL3084 AN ECL3087 AN
  
3 MODULI MODULES 4 MODULI MODULES 7 MODULI MODULES
CONF. CONF. CONF.
BOX BOX BOX
 10 pz 5 pz 5 pz
IMBALLO IMBALLO IMBALLO
PACKAGE PACKAGE PACKAGE
 210 pz 105 pz 60 pz





RAME COPPER **CE**
ECL3083 RM ECL3084 RM ECL3087 RM
  
3 MODULI MODULES 4 MODULI MODULES 7 MODULI MODULES
CONF. CONF. CONF.
BOX BOX BOX
 10 pz 5 pz 5 pz
IMBALLO IMBALLO IMBALLO
PACKAGE PACKAGE PACKAGE
 210 pz 105 pz 60 pz





ACCIAIO SATINATO SATIN STEEL **CE**
ECL3083 AS ECL3084 AS ECL3087 AS
  
3 MODULI MODULES 4 MODULI MODULES 7 MODULI MODULES
CONF. CONF. CONF.
BOX BOX BOX
 10 pz 5 pz 5 pz
IMBALLO IMBALLO IMBALLO
PACKAGE PACKAGE PACKAGE
 210 pz 105 pz 60 pz





METAL BLACK **CE**
ECL3083 MB ECL3084 MB ECL3087 MB
  
3 MODULI MODULES 4 MODULI MODULES 7 MODULI MODULES
CONF. CONF. CONF.
BOX BOX BOX
 10 pz 5 pz 5 pz
IMBALLO IMBALLO IMBALLO
PACKAGE PACKAGE PACKAGE
 210 pz 105 pz 60 pz



CROMO CHROME **CE**
ECL3083 CR ECL3084 CR ECL3087 CR
  
3 MODULI MODULES 4 MODULI MODULES 7 MODULI MODULES
CONF. CONF. CONF.
BOX BOX BOX
 10 pz 5 pz 5 pz
IMBALLO IMBALLO IMBALLO
PACKAGE PACKAGE PACKAGE
 210 pz 105 pz 60 pz



ORO GOLD* **CE**
ECL3083 OR ECL3084 OR ECL3087 OR
  
3 MODULI MODULES 4 MODULI MODULES 7 MODULI MODULES
CONF. CONF. CONF.
BOX BOX BOX
 10 pz 5 pz 5 pz
IMBALLO IMBALLO IMBALLO
PACKAGE PACKAGE PACKAGE
 210 pz 105 pz 60 pz

* Realizzata con bagno galvanico in oro 24 kt
Galvanic coating with 24 kt gold

NEW PRESTIGE® PLACCHE COPRINTERRUTTORI NEW PRESTIGE® COVER PLATES

FINITURE ESCLUSIVE EXCLUSIVE FINISHES



BIANCO PERLA WHITE PEARL

ECL3083 BP ECL3084 BP ECL3087 BP

3 MODULI MODULES 4 MODULI MODULES 7 MODULI MODULES

CONFEZ. BOX	10 pz	CONFEZ. BOX	5 pz	CONFEZ. BOX	5 pz
IMBALLO PACKAGE	210 pz	IMBALLO PACKAGE	105 pz	IMBALLO PACKAGE	60 pz



FIBRA DI CARBONIO CARBON FIBER

ECL3083 FB ECL3084 FB ECL3087 FB

3 MODULI MODULES 4 MODULI MODULES 7 MODULI MODULES

CONFEZ. BOX	10 pz	CONFEZ. BOX	5 pz	CONFEZ. BOX	5 pz
IMBALLO PACKAGE	210 pz	IMBALLO PACKAGE	105 pz	IMBALLO PACKAGE	60 pz



METAL BLACK SATINATO SATIN METAL BLACK

ECL3083 MBS ECL3084 MBS ECL3087 MBS

3 MODULI MODULES 4 MODULI MODULES 7 MODULI MODULES

CONFEZ. BOX	10 pz	CONFEZ. BOX	5 pz	CONFEZ. BOX	5 pz
IMBALLO PACKAGE	210 pz	IMBALLO PACKAGE	105 pz	IMBALLO PACKAGE	60 pz



CROMO SATINATO SATIN CHROME

ECL3083 CRS ECL3084 CRS ECL3087 CRS

3 MODULI MODULES 4 MODULI MODULES 7 MODULI MODULES

CONFEZ. BOX	10 pz	CONFEZ. BOX	5 pz	CONFEZ. BOX	5 pz
IMBALLO PACKAGE	210 pz	IMBALLO PACKAGE	105 pz	IMBALLO PACKAGE	60 pz



ORO SATINATO SATIN GOLD

ECL3083 OS ECL3084 OS ECL3087 OS

3 MODULI MODULES 4 MODULI MODULES 7 MODULI MODULES

CONFEZ. BOX	10 pz	CONFEZ. BOX	5 pz	CONFEZ. BOX	5 pz
IMBALLO PACKAGE	210 pz	IMBALLO PACKAGE	105 pz	IMBALLO PACKAGE	60 pz



SAHARA

ECL3083 SH ECL3084 SH ECL3087 SH

3 MODULI MODULES 4 MODULI MODULES 7 MODULI MODULES

CONFEZ. BOX	10 pz	CONFEZ. BOX	5 pz	CONFEZ. BOX	5 pz
IMBALLO PACKAGE	210 pz	IMBALLO PACKAGE	105 pz	IMBALLO PACKAGE	60 pz



SAHARA SATINATO SATIN SAHARA

ECL3083 SHS ECL3084 SHS ECL3087 SHS

3 MODULI MODULES 4 MODULI MODULES 7 MODULI MODULES

CONFEZ. BOX	10 pz	CONFEZ. BOX	5 pz	CONFEZ. BOX	5 pz
IMBALLO PACKAGE	210 pz	IMBALLO PACKAGE	105 pz	IMBALLO PACKAGE	60 pz



WOOD BLACK

ECL3083 WB ECL3084 WB ECL3087 WB

3 MODULI MODULES 4 MODULI MODULES 7 MODULI MODULES

CONFEZ. BOX	10 pz	CONFEZ. BOX	5 pz	CONFEZ. BOX	5 pz
IMBALLO PACKAGE	210 pz	IMBALLO PACKAGE	105 pz	IMBALLO PACKAGE	60 pz

FINITURE VULCANIZZATE VULCANISED FINISHES



GRIGIO NOTTE DARK GREY

ECL3083 V-GN ECL3084 V-GN ECL3087 V-GN

3 MODULI MODULES 4 MODULI MODULES 7 MODULI MODULES

CONFEZ. BOX	10 pz	CONFEZ. BOX	5 pz	CONFEZ. BOX	5 pz
IMBALLO PACKAGE	210 pz	IMBALLO PACKAGE	105 pz	IMBALLO PACKAGE	60 pz



GRIGIO CHIARO LIGHT GREY

ECL3083 V-GC ECL3084 V-GC ECL3087 V-GC

3 MODULI MODULES 4 MODULI MODULES 7 MODULI MODULES

CONFEZ. BOX	10 pz	CONFEZ. BOX	5 pz	CONFEZ. BOX	5 pz
IMBALLO PACKAGE	210 pz	IMBALLO PACKAGE	105 pz	IMBALLO PACKAGE	60 pz



CARTA DA ZUCCHERO LIGHT BLUE

ECL3083 V-CZ ECL3084 V-CZ ECL3087 V-CZ

3 MODULI MODULES 4 MODULI MODULES 7 MODULI MODULES

CONFEZ. BOX	10 pz	CONFEZ. BOX	5 pz	CONFEZ. BOX	5 pz
IMBALLO PACKAGE	210 pz	IMBALLO PACKAGE	105 pz	IMBALLO PACKAGE	60 pz



VERDE NOTTE DARK GREEN

ECL3083 V-VN ECL3084 V-VN ECL3087 V-VN

3 MODULI MODULES 4 MODULI MODULES 7 MODULI MODULES

CONFEZ. BOX	10 pz	CONFEZ. BOX	5 pz	CONFEZ. BOX	5 pz
IMBALLO PACKAGE	210 pz	IMBALLO PACKAGE	105 pz	IMBALLO PACKAGE	60 pz



ARAGOSTA LOBSTER RED

ECL3083 V-AR ECL3084 V-AR ECL3087 V-AR

3 MODULI MODULES 4 MODULI MODULES 7 MODULI MODULES

CONFEZ. BOX	10 pz	CONFEZ. BOX	5 pz	CONFEZ. BOX	5 pz
IMBALLO PACKAGE	210 pz	IMBALLO PACKAGE	105 pz	IMBALLO PACKAGE	60 pz

FINITURE LEGNO WOODEN-LIKE FINISHES



BETULLA BIRCH



ECL3083 BT ECL3084 BT ECL3087 BT

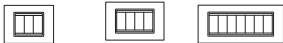

3 MODULI MODULES		4 MODULI MODULES		7 MODULI MODULES	
CONFEZ. BOX	10 pz	CONFEZ. BOX	5 pz	CONFEZ. BOX	5 pz
IMBALLO PACKAGE	210 pz	IMBALLO PACKAGE	105 pz	IMBALLO PACKAGE	60 pz



LEGNO CHIARO LIGHT WOOD



ECL3083 LC ECL3084 LC ECL3087 LC

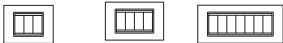

3 MODULI MODULES		4 MODULI MODULES		7 MODULI MODULES	
CONFEZ. BOX	10 pz	CONFEZ. BOX	5 pz	CONFEZ. BOX	5 pz
IMBALLO PACKAGE	210 pz	IMBALLO PACKAGE	105 pz	IMBALLO PACKAGE	60 pz



LEGNO SCURO DARK WOOD



ECL3083 LS ECL3084 LS ECL3087 LS



3 MODULI MODULES		4 MODULI MODULES		7 MODULI MODULES	
CONFEZ. BOX	10 pz	CONFEZ. BOX	5 pz	CONFEZ. BOX	5 pz
IMBALLO PACKAGE	210 pz	IMBALLO PACKAGE	105 pz	IMBALLO PACKAGE	60 pz



RADICA BURL WOOD



ECL3083 RA ECL3084 RA ECL3087 RA



3 MODULI MODULES		4 MODULI MODULES		7 MODULI MODULES	
CONFEZ. BOX	10 pz	CONFEZ. BOX	5 pz	CONFEZ. BOX	5 pz
IMBALLO PACKAGE	210 pz	IMBALLO PACKAGE	105 pz	IMBALLO PACKAGE	60 pz



WENGÉ



ECL3083 WG ECL3084 WG ECL3087 WG

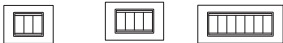

3 MODULI MODULES		4 MODULI MODULES		7 MODULI MODULES	
CONFEZ. BOX	10 pz	CONFEZ. BOX	5 pz	CONFEZ. BOX	5 pz
IMBALLO PACKAGE	210 pz	IMBALLO PACKAGE	105 pz	IMBALLO PACKAGE	60 pz

Le cornici NEW PRESTIGE® hanno una notevole valenza estetica: il loro design essenziale esalta la linea elegante delle placche coprinterruttore NEW PRESTIGE®. Tali cornici, disponibili in tre differenti finiture, inoltre, permettono notevoli possibilità di abbinamento cromatico con gli apparecchi modulari MYLIFE®. Ogni cornice è comunque ordinabile anche separatamente per eventuali predisposizioni.

NEW PRESTIGE® frames have a great attractive valency: their essential design enhances the fine line of NEW PRESTIGE® cover plates. These frames, available in three different finishes, allow many possibilities of chromatic matching with MYLIFE® modular devices. In any case, additional frames could be ordered separately for other possible uses.

CORNICI PER PLACCHE NEW PRESTIGE® FRAMES FOR NEW PRESTIGE® COVER PLATES

CROMO CHROME			GRIGIO GREY			BIANCO WHITE		
ECL3981-3CR	ECL3981-4CR	ECL3981-7CR	ECL3981-3	ECL3981-4	ECL3981-7	ECL3981-3WH	ECL3981-4WH	ECL3981-7WH
3 MODULI MODULES	4 MODULI MODULES	7 MODULI MODULES	3 MODULI MODULES	4 MODULI MODULES	7 MODULI MODULES	3 MODULI MODULES	4 MODULI MODULES	7 MODULI MODULES
CONFEZ. BOX	CONFEZ. BOX	CONFEZ. BOX	CONFEZ. BOX	CONFEZ. BOX	CONFEZ. BOX	CONFEZ. BOX	CONFEZ. BOX	CONFEZ. BOX
50 pz	40 pz	25 pz	50 pz	40 pz	25 pz	50 pz	40 pz	25 pz
IMBALLO PACKAGE	IMBALLO PACKAGE	IMBALLO PACKAGE	IMBALLO PACKAGE	IMBALLO PACKAGE	IMBALLO PACKAGE	IMBALLO PACKAGE	IMBALLO PACKAGE	IMBALLO PACKAGE
800 pz	640 pz	400 pz	800 pz	640 pz	400 pz	800 pz	640 pz	400 pz

MONTAGGIO PLACCA NEW PRESTIGE® SU APPARECCHI MYLIFE® NEW PRESTIGE® COVER PLATE ASSEMBLING ON MYLIFE® DEVICES

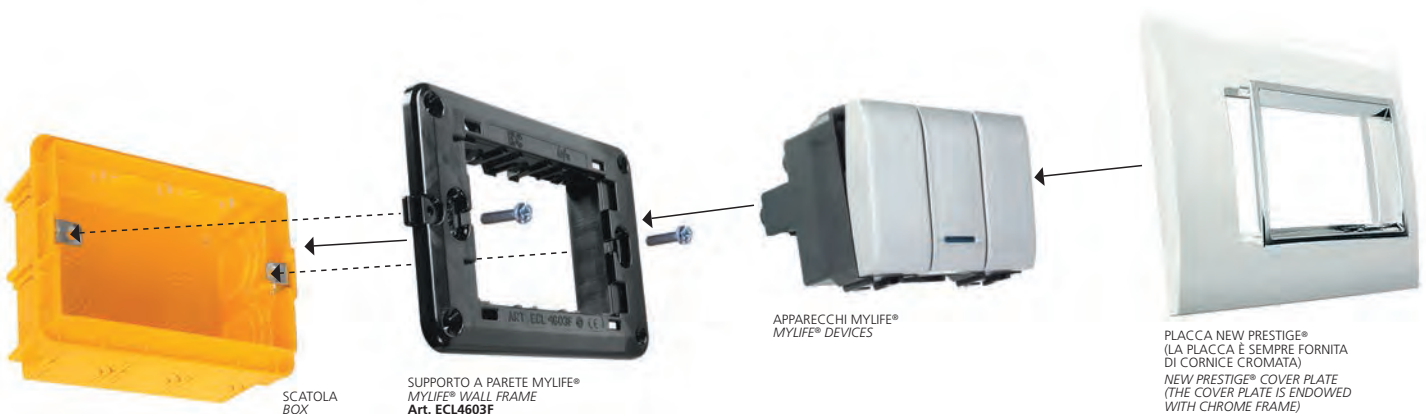

PERSONALIZZAZIONE PLACCHE COPRINTERRUTTORE NEW PRESTIGE® NEW PRESTIGE® COVER PLATES PERSONALIZATION

La personalizzazione delle placche NEW PRESTIGE® avviene con la tecnologia a laser, che consente di riprodurre qualsiasi simbolo, logo o marchio sulla placca, con la massima precisione delle linee e dei tratti, garantendo l'indelebilità e l'inalterabilità nel tempo.

NEW PRESTIGE® cover plates personalization is possible by a laser technology that allows reproducing any symbol, logo or mark on cover plate, with a great precision of lines and features, guaranteeing the permanent marker and the inalterability.

Questa tecnologia a laser consente di incidere il simbolo, il logo o il marchio prescelto solo in modo monocromatico, non a colori, e la resa cromatica finale della grafica dipende dal colore della placca scelta per la personalizzazione.

This laser technology allows reproducing any symbol, logo or mark only in a monochrome way, not colored, and the final chromatic result depends from cover plate color chosen for the personalization.

Non sono personalizzabili i seguenti colori e finiture:
COLORE CROMO - ORO - METAL BLACK;
FINITURE VULCANIZZATE - LEGNO - ESCLUSIVE.

*It is not possible to personalize the following colours and finishes:
CHROME - GOLD - METAL BLACK COLOURS;
VULCANISED - WOODEN-LIKE - EXCLUSIVE FINISHES.*

La personalizzazione può essere richiesta solo per quantitativi significativi.

The personalization could be required only for high quantities.

Per richiedere la personalizzazione è necessario:

- Inviare via mail la grafica scelta come immagine digitale in bianco e nero nei seguenti formati EPS-TIFF-JPEG;
- Scegliere il riquadro della placca in cui si vuole inserire.

To require the personalization is necessary:

- Send by email as black and white digital picture in following format EPS-TIFF-JPEG;
- Choose cover plate frame in which will be reproduced.

Nella figura sottostante, i due rettangoli rossi evidenziano le zone della placca dove è possibile riprodurre la grafica.

In the picture below, two red rectangles identify cover plate frames in which is possible to reproduce graphic design.

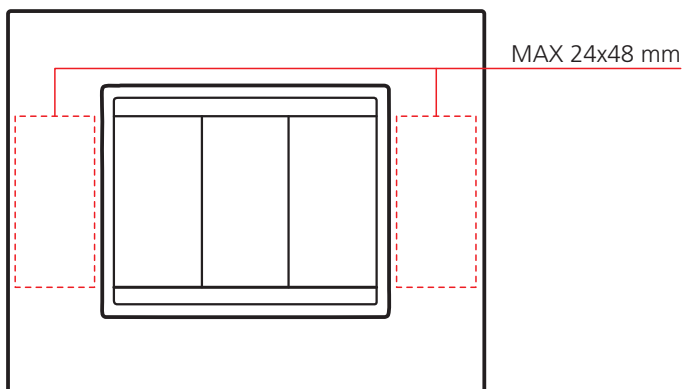

**ESEMPIO PERSONALIZZAZIONE PLACCA NEW PRESTIGE
NEW PRESTIGE COVER PLATES PERSONALIZATION EXAMPLE**





Le serie di contenitori da parete ECL5610 - IP40 ed ECL5611 - IP55 per apparecchi MYLIFE® si contraddistinguono per il design rinnovato e l'adeguamento di alcune caratteristiche tecniche. Risalta subito all'occhio l'aspetto moderno e minimale così come immediatamente si potranno apprezzare la robustezza degli involucri e la grande semplicità d'installazione ed utilizzo.

ECL5610 - IP40 and ECL5611 - IP55 wall mounting boxes series for MYLIFE® electrical devices stand out for their improved design and for adaptation to some technical features.

This new series is characterized for modern and minimal aspect in addition to its strength and its easy installation and use.

CONTENITORI DA PARETE WALL MOUNTING BOXES



ECL5610A1
Contenitore da parete
per 1 apparecchio tipo MYLIFE®
Wall box
for 1 MYLIFE® electrical device

CONFEZ. BOX 1 pz IP40
Grigio/Grey RAL 7035
IMBALLO PACKAGE 60 pz Dimensioni/Size: 76,5x76,5x56,5 mm



ECL5610A2
Contenitore da parete
per 2 apparecchi tipo MYLIFE®
Wall box
for 2 MYLIFE® electrical devices

CONFEZ. BOX 1 pz IP40
Grigio/Grey RAL 7035
IMBALLO PACKAGE 60 pz Dimensioni/Size: 76,5x76,5x56,5 mm



ECL5610A3
Contenitore da parete
per 3 apparecchi tipo MYLIFE®
Wall box
for 3 MYLIFE® electrical devices

CONFEZ. BOX 1 pz IP40
Grigio/Grey RAL 7035
IMBALLO PACKAGE 40 pz Dimensioni/Size: 101x76,5x56,5 mm



ECL5610A4
Contenitore da parete
per 4 apparecchi tipo MYLIFE®
Wall box
for 4 MYLIFE® electrical devices

CONFEZ. BOX 1 pz IP40
Grigio/Grey RAL 7035
IMBALLO PACKAGE 30 pz Dimensioni/Size: 125,5x76,5x56,5 mm



CONTENITORI DA PARETE CON PORTELLO WALL MOUNTING BOXES WITH HATCH

La serie di contenitori da parete protetti IP55 si impone per la nuova funzione di blocco del portello in posizione di apertura; una caratteristica che rende assolutamente pratico l'accesso agli apparecchi modulari.

The IP55 wall mounting box series stand out for its new block function of hatch in open position. It is a feature that make very easily electrical devices installation.



ECL5611A1

Contenitore da parete con portello per 1 apparecchio tipo MYLIFE®

Wall box with hatch for 1 MYLIFE® electrical device

CONFEZ. BOX 1 pz **IP55**
Grigio/Grey RAL 7035
IMBALLO PACKAGE 50 pz Dimensioni/Size: 76,5x76,5x64,5 mm



ECL5611A2

Contenitore da parete con portello per 2 apparecchi tipo MYLIFE®

Wall box with hatch for 2 MYLIFE® electrical devices

CONFEZ. BOX 1 pz **IP55**
Grigio/Grey RAL 7035
IMBALLO PACKAGE 50 pz Dimensioni/Size: 76,5x76,5x64,5 mm



ECL5611A3

Contenitore da parete con portello per 3 apparecchi tipo MYLIFE®

Wall box with hatch for 3 MYLIFE® electrical devices

CONFEZ. BOX 1 pz **IP55**
Grigio/Grey RAL 7035
IMBALLO PACKAGE 35 pz Dimensioni/Size: 101x76,5x64,5 mm



ECL5611A4

Contenitore da parete con portello per 4 apparecchi tipo MYLIFE®

Wall box with hatch for 4 MYLIFE® electrical devices

CONFEZ. BOX 1 pz **IP55**
Grigio/Grey RAL 7035
IMBALLO PACKAGE 25 pz Dimensioni/Size: 125,5x76,5x64,5 mm

CONTENITORI SPECIALI SPECIAL DISTRIBUTION BOARD BOXES



ECLSM3

Mini scatola per 2 apparecchi o per 1 apparecchio SCHUKO tipo MYLIFE® - Pretranciato per minicanalina

Mini box for 2 or 1 SCHUKO MYLIFE® electrical devices Equipped for installation on minitrunking

CONFEZ. BOX 1 pz **IP40**
Bianco/White RAL 9001
IMBALLO PACKAGE 30 pz Dimensioni/Size: 56x58x51 mm



ECLKITSM3

Kit n. 2 adattatori per installazione su art. ECLSM3 di 1 o 2 apparecchi tipo TONDÒ®

Kit n. 2 adaptors to install on art. ECLSM3 1 or 2 TONDÒ® electrical devices

CONFEZ. BOX 1 pz **IP40**
Bianco/White RAL 9001
IMBALLO PACKAGE 30 pz



ECL4611Q

Contenitore da quadro con portello per 2 apparecchi tipo MYLIFE®

Distribution board box with hatch for 2 MYLIFE® electrical devices

CONFEZ. BOX 1 pz **IP55**
Grigio/Grey RAL 7035
IMBALLO PACKAGE 30 pz

CONTENITORI DA PARETE WALL MOUNTING BOXES



ECL4610A1

Contenitore da parete per 1 apparecchio tipo MYLIFE®

Wall box for 1 MYLIFE® electrical device

CONFEZ. BOX 1 pz **IP40**
Grigio/Grey RAL 7035
IMBALLO PACKAGE 60 pz Dimensioni/Size: 67x83x51 mm



ECL4610A2

Contenitore da parete per 2 apparecchi tipo MYLIFE®

Wall box for 2 MYLIFE® electrical devices

CONFEZ. BOX 1 pz **IP40**
Grigio/Grey RAL 7035
IMBALLO PACKAGE 60 pz Dimensioni/Size: 67x83x51 mm



ECL4610A3

Contenitore da parete per 3 apparecchi tipo MYLIFE®

Wall box for 3 MYLIFE® electrical devices

CONFEZ. BOX 1 pz **IP40**
Grigio/Grey RAL 7035
IMBALLO PACKAGE 40 pz Dimensioni/Size: 100x83x51 mm

CONTENITORI DA PARETE WALL MOUNTING BOXES



ECL4610A4

Contenitore da parete per 4 apparecchi tipo MYLIFE®

Wall box for 4 MYLIFE® electrical devices

CONFEZ. BOX 1 pz
IMBALLO PACKAGE 30 pz

IP40
Grigio/Grey RAL 7035
Dimensioni/Size: 122x83x51 mm



ECL4610A4V

Contenitore da parete per 4 apparecchi verticali tipo MYLIFE®

Wall box for 4 MYLIFE® vertical electrical devices

CONFEZ. BOX 1 pz
IMBALLO PACKAGE 25 pz

IP40
Grigio/Grey RAL 7035
Dimensioni/Size: 67x180x51 mm



ECL4610A6V

Contenitore da parete per 6 apparecchi verticali tipo MYLIFE®

Wall box for 6 MYLIFE® vertical electrical devices

CONFEZ. BOX 1 pz
IMBALLO PACKAGE 18 pz

IP40
Grigio/Grey RAL 7035
Dimensioni/Size: 100x180x51 mm



CONTENITORI DA PARETE CON PORTELLO WALL MOUNTING BOXES WITH HATCH



ECL4611A1

Contenitore da parete con portello per 1 apparecchio tipo MYLIFE®

Wall box with hatch for 1 MYLIFE® electrical device

CONFEZ. BOX 1 pz
IMBALLO PACKAGE 50 pz

IP55
Grigio/Grey RAL 7035
Dimensioni/Size: 67x83x59 mm



ECL4611A2

Contenitore da parete con portello per 2 apparecchi tipo MYLIFE®

Wall box with hatch for 2 MYLIFE® electrical devices

CONFEZ. BOX 1 pz
IMBALLO PACKAGE 50 pz

IP55
Grigio/Grey RAL 7035
Dimensioni/Size: 67x83x59 mm



ECL4611A3

Contenitore da parete con portello per 3 apparecchi tipo MYLIFE®

Wall box with hatch for 3 MYLIFE® electrical devices

CONFEZ. BOX 1 pz
IMBALLO PACKAGE 35 pz

IP55
Grigio/Grey RAL 7035
Dimensioni/Size: 100x83x59 mm



ECL4611A4

Contenitore da parete con portello per 4 apparecchi tipo MYLIFE®

Wall box with hatch for 4 MYLIFE® electrical devices

CONFEZ. BOX 1 pz
IMBALLO PACKAGE 25 pz

IP55
Grigio/Grey RAL 7035
Dimensioni/Size: 122x83x59 mm



ECL4611A4V

Contenitore da parete con portello per 4 apparecchi verticali tipo MYLIFE®

Wall box with hatch for 4 MYLIFE® vertical electrical devices

CONFEZ. BOX 1 pz
IMBALLO PACKAGE 20 pz

IP55
Grigio/Grey RAL 7035
Dimensioni/Size: 67x180x59 mm



ECL4611A6V

Contenitore da parete con portello per 6 apparecchi verticali tipo MYLIFE®

Wall box with hatch for 6 MYLIFE® vertical electrical devices

CONFEZ. BOX 1 pz
IMBALLO PACKAGE 15 pz

IP55
Grigio/Grey RAL 7035
Dimensioni/Size: 100x180x59 mm



PLACCHE AUTOPORTANTI CON PORTELLO SELF-SUPPORTING PLATES WITH HATCH



ECL4611B

Placca autoportante con portello per 3 apparecchi tipo MYLIFE®

Self-supporting plate with hatch for 3 MYLIFE® electrical devices

CONFEZ. BOX 1 pz
IMBALLO PACKAGE 40 pz

CE IP55
Bianco/White RAL 9001
Dimensioni/Size: 130x85x26 mm



ECL4611G

Placca autoportante con portello per 3 apparecchi tipo MYLIFE®

Self-supporting plate with hatch for 3 MYLIFE® electrical devices

CONFEZ. BOX 1 pz
IMBALLO PACKAGE 40 pz

CE IP55
Grigio/Grey RAL 7035
Dimensioni/Size: 130x85x26 mm



ECL4611N

Placca autoportante con portello per 3 apparecchi tipo MYLIFE®

Self-supporting plate with hatch for 3 MYLIFE® electrical devices

CONFEZ. BOX 1 pz
IMBALLO PACKAGE 40 pz

CE IP55
Antracite RAL 7021
Dimensioni/Size: 130x85x26 mm

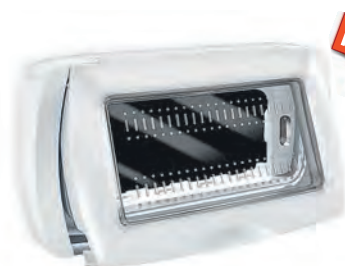

ECL46114B

Placca autoportante con portello per 4 apparecchi tipo MYLIFE®

Self-supporting plate with hatch for 4 MYLIFE® electrical devices

CONFEZ. BOX 1 pz
IMBALLO PACKAGE 20 pz

CE IP55
Bianco/White RAL 9001
Dimensioni/Size: 154x85x26 mm



ECL46114G

Placca autoportante con portello per 4 apparecchi tipo MYLIFE®

Self-supporting plate with hatch for 4 MYLIFE® electrical devices

CONFEZ. BOX 1 pz
IMBALLO PACKAGE 20 pz

CE IP55
Grigio/Grey RAL 7035
Dimensioni/Size: 154x85x26 mm



ECL46114N

Placca autoportante con portello per 4 apparecchi tipo MYLIFE®

Self-supporting plate with hatch for 4 MYLIFE® electrical devices

CONFEZ. BOX 1 pz
IMBALLO PACKAGE 20 pz

CE IP55
Antracite RAL 7021
Dimensioni/Size: 154x85x26 mm



SISTEMA DI CHIAMATA OSPEDALIERO/ALBERGHIERO MEDICAL/HOTEL CALLING SYSTEM

Il sistema di chiamata ELETTRICANALI si integra esteticamente con la serie civile MYLIFE® ed è ideale per gestire le emergenze, migliorare la rapidità di intervento ed ottimizzare le risorse a disposizione in qualsiasi struttura ospedaliera, casa di cura, clinica privata e qualsiasi struttura alberghiera.

ELETTROCANALI call system is created to fit aesthetically with MYLIFE® civil series and it is adapt to manage emergencies, improve intervention rapidity and optimize human resources in each types of hospital, health care centre, rest house and any type of hotels.

ESEMPIO DI APPLICAZIONE IN STRUTTURA OSPEDALIERA
MODALITA' DI FUNZIONAMENTO

Tutte le stanze dei degenti sono collegate al sistema tramite dispositivi di chiamata (art.ECL4021-pulsante o art.ECL4024-pulsante con corda) presenti in prossimità dei letti e nei locali bagno.

La semplice attivazione di tali dispositivi attiva istantaneamente il sistema di chiamata che provvede a:

- inoltrare l'avviso di chiamata sui display installati nei locali di presidio del personale medico;
- segnalare acusticamente e visivamente l'avviso di chiamata mediante un dispositivo (art. ECL4077) installato fuori la stanza del degente.

Il personale medico, attraverso il display, identifica la stanza da cui proviene la chiamata ed dopo aver raggiunto il paziente provvede a tacitare l'allarme mediante l'apposito dispositivo situato nella stanza (art.ECL4061-interruttore con chiave) segnalando così l'avvenuto intervento.

APPLICATION EXAMPLE IN A MEDICAL STRUCTURE
OPERATION MODE

Each inpatient room is connected with the system through calling devices (art.ECL4021-push button or art.ECL4024-push button with cord) which are installed near the beds and in the bathrooms.

The simple activation on these devices activates immediately the calling system that provides for:

- forwarding call advice on displays installed in medical staff rooms;
- signalling call advice with an optical-hearing emergency device (art.ECL4077) installed out of inpatient room.

Medical staff, through the display, identifies the room from which comes the call and, after reached inpatient, provides to off the alarm through the device (art.ECL4061-1 way single pole switch with key) installed in the room, to signal the occurred intervention.

CHIAMATA CALLING

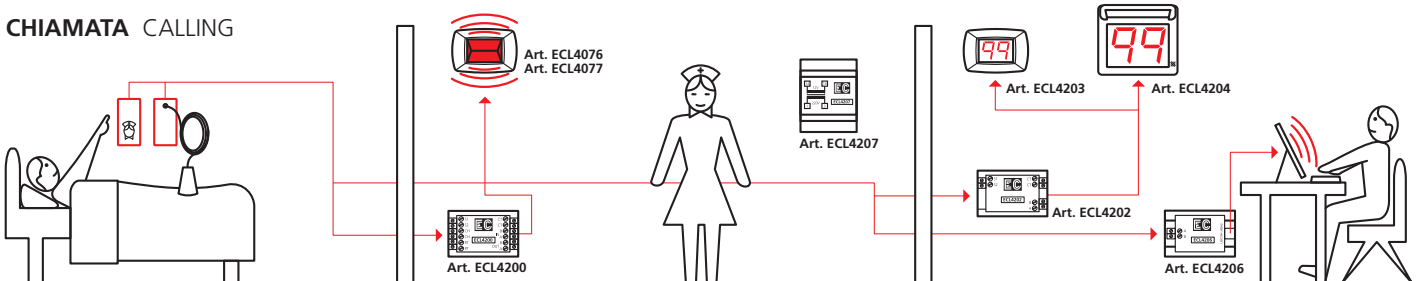

TACITAZIONE OFF



PRINCIPALI CARATTERISTICHE

- Possibilità di realizzare impianti di segnalazione fino a 99 chiamate.
- Capacità di autoprogrammazione dell'intera rete.
- Chiamata tramite pulsante o pulsante a tirante, con segnalazione ottico acustico permanente.
- Visualizzazione del numero corrispondente sul quadro display posto in luogo presidiato dal personale medico.
- Memorizzazione delle chiamate contemporanee e visualizzazione sul quadro display dei relativi numeri, dopo l'annullamento della chiamata evasa.
- Possibilità di ripetizione delle chiamate su altri quadri display (ripetitori).
- Contatto ausiliario per singola stanza per il pilotaggio di altri dispositivi di segnalazione.
- Cablaggio dell'impianto con sistema a BUS (2+2).
- Alloggiamento dell'unità display in una comune scatola 503.

MAIN FEATURES

- Possibility of realise control systems with up 99 calls.
- Self-setting capability of network.
- Calling system through push button or push button with cord, with permanent optical and acoustic signal.
- Calling number display on panel display positioned in medical staff rooms.
- Contemporary calls storage and display on the panel display of the number after the reset of the previous call.
- Calling repetition possibility on other repeater displays.
- Auxiliary contact for each room to drive other signal devices.
- Wiring system with BUS system (2+2).
- Master unit display housing in a common electric wall box (503).

COMPONENTI DEL SISTEMA SYSTEM COMPONENTS



ECL4200

Concentratore di camera
Room interface

IMBALLO
PACKAGE 1 pz



Costituisce un'interfaccia tra il circuito analogico dell'impianto (pulsanti di chiamata e di reset) e il circuito digitale del master (trasferimento dati BUS).

Questa unità, durante la fase di autoprogrammazione dell'impianto, genera un codice identificativo unico di chiamata che pone nella propria memoria e che trasmette al master ogni qualvolta si verifica una chiamata, facendosi riconoscere dal sistema.

Questo apparecchio, inoltre, è dotato di un contatto pulito di tipo N/O da 2A, con il quale è possibile comandare ulteriori dispositivi remoti di segnalazione. Alloggiato in un contenitore plastico predisposto per l'inserimento in scatole di derivazione o intercapedine del testaletto.

CARATTERISTICHE

Alimentazione: 12V~
Potenza assorbita: max 1W
Dimensioni: 80x50x20 mm

It's the interface between analogical system (call and reset devices) and master digital system (BUS data transfer).

This unit, during self-setting system, generates an identificative call code, saves in memory this code and each time that an emergency call happens, it transfers this code to the master.

This devices is composed by a clean contact type N/O 2A, with that is possible manage other external additional devices for local signalling.

It can be housed in a wall box or in the head of the bed.

FEATURES

Power supply: 12V~
Power absorption: max 1W
Size: 80x50x20 mm



ECL4201

Unità di reset generale
General reset unit

IMBALLO
PACKAGE 1 pz



Questa unità, montata nei pressi del quadro display, genera un segnale di reset per il quadro display in modo da azzerare una qualsiasi chiamata corrente, evitando quindi di dover resettare dalla camera chiamante.

Questa unità può essere montata da sola o in aggiunta al reset di camera generato dal concentratore di camera.

Alloggiato in un contenitore plastico per l'inserimento in scatole di derivazione.

CARATTERISTICHE

Alimentazione: 12V~
Potenza assorbita: max 1W
Dimensioni: 80x50x20 mm

This unit, installed near the panel display, generates a reset signal that eliminates all calls received by the system, precluding to have to reset from the calling room. It can be used alone or in addition to the room reset generated by the room interface.

It can be housed in a wall box.

FEATURES

Power supply: 12V~
Power absorption: max 1W
Size: 80x50x20 mm



ECL4202

Unità di contatto remoto
 Remote contact unit

IMBALLO
 PACKAGE 1 pz



Costituisce un'interfaccia tra il circuito digitale (BUS di comunicazione) e il circuito analogico dell'impianto fornendo un contatto pulito di tipo N/O.

Questo dispositivo intercetta il segnale di qualsiasi chiamata che transita sul BUS dati e chiude il contatto, che rimane in questo stato per tutta la durata della chiamata in corso e/o delle altre eventuali chiamate memorizzate.

L'azzeramento di tutte le chiamate in corso tramite i rispettivi pulsanti di reset, provoca l'apertura del contatto del dispositivo.

La portata del contatto è di 2A, ed è possibile comandare con esso ulteriori dispositivi remoti di segnalazione.

Alloggiato in un contenitore plastico predisposto per l'inserimento in scatole di derivazione.

It's the interface between digital system (communication BUS) and analogical system.

This device intercepts each call signal passing on data BUS and closes the contact. The contact will be closed until the end current call, or other following memorised calls.

Through the reset button, all calls are eliminated, and the device contact is opened.

This devices is composed by a clean contact type N/O 2A, with that is possible manage other external additional devices for local signalling.

It can be housed in a wall box.

CARATTERISTICHE

Alimentazione: 12V~

Potenza assorbita: max 1W

Dimensioni: 80x50x20 mm

FEATURES

Power supply: 12V~

Power absorption: max 1W

Size: 80x50x20 mm



ECL4203

Quadro digitale di segnalazione numerica
 Digital panel display for numeric signalling

IMBALLO
 PACKAGE 1 pz



È l'unità display, alimentato a 12V~, che consente di realizzare impianti di segnalazione fino a 99 chiamate.

Il collegamento tra questo dispositivo e le unità del sistema (ECL4200-ECL4201-ECL4202) si effettuano con un sistema a BUS costituito da due conduttori per la linea dati (A-B) e due conduttori per la linea di alimentazione che deve essere comune a tutto l'impianto e proporzionato per il massimo assorbimento.

It's the display unit, powered to 12V~, that allows control over installations with up 99 calls.

The connection between this devices and the other system units (ECL4200-ECL4201-ECL4202) is possible with a BUS system, composed of 2 conductors for data line (A-B) and 2 conductors for power line that would be the same in the whole system and proportionate for max absorption.

COMPONENTI DEL SISTEMA SYSTEM COMPONENTS



ECL4204

Quadro digitale di segnalazione numerica big
Big digital panel display for numeric signalling

IMBALLO
PACKAGE 1 pz



È realizzato in ABS e corredato di accessori per il fissaggio a parete o a soffitto. Alimentato a 12V~, consente di realizzare impianti di segnalazione fino a 99 chiamate.

It's produced in ABS and it's equipped with accessories for the installation on the wall or on ceiling. Powered to 12V~, it allows control over installations with up 99 calls.

CARATTERISTICHE

Potenza assorbita: max 6W
Altezza Digit: 135mm
Angolo visuale: 150°
Dimensioni: 275x240x55 mm
Peso: 1kg
Temperatura di funzionamento: 0°/50°

FEATURES

*Power absorption: max 6W
Digit high: 135mm
Visual angle: 150°
Size: 275x240x55 mm
Weight: 1kg
Operation temperature: 0°/50°*



ECL4206

Interfaccia USB e software
USB interface and software

IMBALLO
PACKAGE 1 pz



Questa unità costituisce una periferica di interfaccia tra un PC e le unità dell'impianto di segnalazione (ECL4200-ECL4201-ECL4202). Essa esplica tutte le funzioni del quadro master, riguardante lo scambio di informazioni con gli altri componenti costituenti l'impianto ed inoltre è in grado di colloquiare con un PC tramite porta USB, nel quale un apposito software gestisce la comunicazione con la periferica e visualizza le eventuali chiamate sullo schermo. Tale software trasforma il computer in un terminale di supervisione, permettendo al personale di gestire tutto il sistema dal PC.

This unit is an interface outlet between a PC and the call system units (ECL4200-ECL4201-ECL4202). It makes all functions of master panel as information exchange with the other units and also it is able to communicate with a PC through a USB door, in which a software manages the whole system. This software transform the PC in a supervision terminal, that allows staff to manage the whole call system by PC.

CARATTERISTICHE DELL'INTERFACCIA USB

Alimentazione: 12V~
Potenza assorbita: max 1W
Dimensioni: 85x50x20 mm

REQUISITI DEL PC PER L'INSTALLAZIONE DEL SOFTWARE

Sistema operativo: Windows 98, 2000, Millennium o XP
Processore: Min Pentium II - Spazio libero su hard disk: 20MB
Requisiti minimi RAM: 64MB Windows 98 / Millennium , 128 MB XP

INTERFACE USB FEATURES

*Power supply: 12V~
Power absorption: max 1W
Size: 85x50x20 mm*

PC FEATURES FOR SOFTWARE INSTALLATION

*Operative system: Windows 98, 2000, Millennium o XP
Processor: Min Pentium II - Free space on hard disk: 20MB
RAM min features: 64MB Windows 98 / Millennium , 128 MB XP*



ECL4207

Trasformatore modulare per l'alimentazione del sistema di chiamata
 Modular transformer for system call supply

IMBALLO
 PACKAGE 1 pz



Trasformatore monofase con primario a 230V~ e secondario a 12V~, con una potenza proporzionata al massimo assorbimento dell'impianto. A titolo informativo si fornisce una formula pratica per il dimensionamento del trasformatore di alimentazione. P (potenza trasformatore espressa in VA) = No (numero dispositivi impiegati) x 2. Esempio: impianto chiamata per 50 camere: P = 50 x 2 = 100VA. Secondo gli spazi disponibili, per raggiungere la potenza necessaria calcolata sopra è possibile utilizzare sia più trasformatori con collegamento in parallelo, sia un unico trasformatore.

CARATTERISTICHE

- 4 moduli DIN
- Potenza: 63VA
- Tensione di alimentazione (primario): 230V~
- Tensione di uscita (secondario): 12V~
- Frequenza: 50/60 Hz

Monophase transformer with primary system to 230V~ and secondary system to 12V~, with a supply power proportionate to max system absorption. For information here below a practical pattern to calculate the power supply necessary for transformer. P (power supply in VA) = No (number of system unit) x 2. Example: call system for 50 rooms: P = 50x2 = 100VA. According the available space, to get the calculated total power, it is possible to use more transformers with parallel connection but also just a single transformer.

FEATURES

- 4 DIN modules
- Power: 63VA
- Supply voltage (primary): 230V~
- Exit voltage (secondary): 12V~
- Frequency: 50/60 Hz





NOVITÀ NEW

Apparecchi modulari e placche coprinterruttori

Easy è una nuova serie Elettrocanali® di apparecchi modulari e placche coprinterruttori pensata sia per i contesti residenziali che per gli ambienti commerciali. Il design minimalista e le linee eleganti tipicamente italiane di questo sistema vengono incontro ad ogni esigenza estetica. L'eccelsa qualità dei componenti, la modularità e la semplicità d'installazione esprimono il massimo in termini di sicurezza, versatilità e praticità. Tutte le funzioni necessarie ed una selezione di colori in abbinamento realizzano il connubio perfetto tra gli apparecchi e le placche, tra l'interior design ed il benessere abitativo, senza alcun compromesso nella tecnica progettuale e costruttiva.

Modular devices and cover plates

Easy is a new Elettrocanali® series of modular devices and cover plates designed for residential contexts and also for commercial environments. Minimalist design and elegant lines characterise this Italian system and satisfy every aesthetic need. Excellent quality of the components, modularity and simplicity of installation express the maximum in terms of safety, versatility and practicality. All necessary functions and a selection of matching colors make perfect union between electrical devices and cover plates, between interiors design and living well-being, without any compromise in technique design and construction.



APPARECCHI DI COMANDO BASE ILLUMINABILI BASIC LIGHTABLE SWITCHING DEVICES

Specifiche tecniche a pag. 119
Technical features page 119



ECSE8001

Interruttore unipolare illuminabile
(lampada spia non inclusa)

*Lightable 1 way single pole switch
(indicator lamp not supplied)*

CONFEZ BOX 12 pz
IMBALLO PACKAGE 240 pz



16AX 250V~



ECSE8003

Deviatore unipolare illuminabile
(lampada spia non inclusa)

*Lightable 2 way single pole switch
(indicator lamp not supplied)*

CONFEZ BOX 12 pz
IMBALLO PACKAGE 240 pz



16AX 250V~



ECSE8012

Invertitore unipolare illuminabile
(lampada spia non inclusa)

*Lightable intermediate single pole switch
(indicator lamp not supplied)*

CONFEZ BOX 12 pz
IMBALLO PACKAGE 240 pz



16AX 250V~



ECSE8011

Interruttore bipolare illuminabile
(lampada spia non inclusa)

*Lightable 1 way double pole switch
(indicator lamp not supplied)*

CONFEZ BOX 12 pz
IMBALLO PACKAGE 240 pz



16AX 250V~



ECSE8005

Pulsante unipolare illuminabile
(lampada spia non inclusa)

*Lightable push button
(indicator lamp not supplied)*

CONFEZ BOX 12 pz
IMBALLO PACKAGE 240 pz



16A 250V~ 1P/NO



ECL400LD

Lampada spia a LED cavo mm 100

Indicator LED lamp with 100 mm cable

CONFEZ BOX 50 pz



Colore LED: blu
LED color: blue
230V~ 0,125W 0,5mA max

APPARECCHI DI COMANDO BASE BASIC SWITCHING DEVICES



ECSE8006

Pulsante unipolare a tirante

Push button with cord

CONFEZ BOX 6 pz
IMBALLO PACKAGE 120 pz



Lunghezza cordino 1,5 m
Cord length 1,5 m
16A 250V~ 1P/NO



ECSE8037

Doppio pulsante interbloccato
(1P/NO)+(1P/NO)

*Interlocked twin single pole push button
(1P/NO)+(1P/NO)*

CONFEZ BOX 12 pz
IMBALLO PACKAGE 240 pz



10A 250V~

Specifiche tecniche a pag. 119
Technical features page 119



ECSE8035

Doppio pulsante (1P/NO)+(1P/NO)

Twin single pole push button (1P/NO)+(1P/NO)

CONFEZ BOX 12 pz
IMBALLO PACKAGE 240 pz



10A 250V~

Specifiche tecniche a pag. 119
Technical features page 119

COPRITASTO INTERCAMBIABILE 1 MODULO 1 MODULE INTERCHANGEABLE COVER



ECSE8000

Falso polo

Blank cap

CONFEZ BOX 36 pz
IMBALLO PACKAGE 620 pz



PRESE DI CORRENTE OUTLET SOCKETS



ECSE8013

Presà italiana con sicurezza
Italian shuttered socket

CONFÈZ	12 pz
BOX	
IMBALLO	240 pz
PACKAGE	



10A 250V~
2P+⊕
Standard P11



ECSE8080

Presà italiana bivalente con sicurezza
Italian double shuttered socket

CONFÈZ	12 pz
BOX	
IMBALLO	240 pz
PACKAGE	



10/16A 250V~
2P+⊕
Standard P17/P11



ECSE8040

Presà italiana/tedesca trivalente con sicurezza 2 moduli
Italian/German triple shuttered socket 2 modules

CONFÈZ	6 pz
BOX	
IMBALLO	120 pz
PACKAGE	



10/16A 250V~
2P+⊕ centrale/central
Standard P40

PRESE DI CORRENTE PER IMPIANTI DEDICATI OUTLET SOCKETS FOR DEDICATED EQUIPMENT

ROSSO RED



ECSE8080R

Presà italiana bivalente con sicurezza
Italian double shuttered socket

CONFÈZ	12 pz
BOX	
IMBALLO	240 pz
PACKAGE	



10/16A 250V~
2P+⊕
Standard P17/P11



ECSE8040R

Presà italiana/tedesca trivalente con sicurezza 2 moduli
Italian/German triple shuttered socket 2 modules

CONFÈZ	6 pz
BOX	
IMBALLO	120 pz
PACKAGE	



10/16A 250V~
2P+⊕ centrale/central
Standard P40

ARANCIO ORANGE



ECSE8080AR

Presà italiana bivalente con sicurezza
Italian double shuttered socket

CONFÈZ	12 pz
BOX	
IMBALLO	240 pz
PACKAGE	



10/16A 250V~
2P+⊕
Standard P17/P11



ECSE8040AR

Presà italiana/tedesca trivalente con sicurezza 2 moduli
Italian/German triple shuttered socket 2 modules

CONFÈZ	6 pz
BOX	
IMBALLO	120 pz
PACKAGE	



10/16A 250V~
2P+⊕ centrale/central
Standard P40

VERDE GREEN

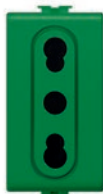

ECSE8080V

Presà italiana bivalente con sicurezza
Italian double shuttered socket

CONFÈZ	12 pz
BOX	
IMBALLO	240 pz
PACKAGE	



10/16A 250V~
2P+⊕
Standard P17/P11

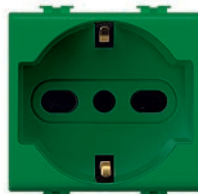

ECSE8040V

Presà italiana/tedesca trivalente con sicurezza 2 moduli
Italian/German triple shuttered socket 2 modules

CONFÈZ	6 pz
BOX	
IMBALLO	120 pz
PACKAGE	



10/16A 250V~
2P+⊕ centrale/central
Standard P40

PRESE TELEFONICHE E TRASMISSIONE DATI TELEPHONE AND DATA SOCKETS

Specifiche tecniche a pag. 122,123,124
Technical features page 122, 123, 124



ECSE8989C4

Presca telefonica RJ11 plug 6/4
RJ12 plug 6/6 autocrimpante
Self-crimping telephone socket
RJ11 plug 6/4 RJ12 plug 6/6

CONFEX BOX	6 pz
IMBALLO PACKAGE	120 pz



ECSE8989C5

Presca RJ45 cat 5e UTP autocrimpante
non schemata
Self-crimping RJ45 socket cat 5e UTP

CONFEX BOX	6 pz
IMBALLO PACKAGE	120 pz



ECSE8989C8

Presca RJ45 cat 5e FTP autocrimpante
schermata
Self-crimping RJ45 socket cat 5e FTP

CONFEX BOX	6 pz
IMBALLO PACKAGE	120 pz



ECSE8989C6

Presca RJ45 cat 6 UTP autocrimpante
non schermata
Self-crimping RJ45 socket cat 6 UTP

CONFEX BOX	6 pz
IMBALLO PACKAGE	120 pz



ECSE8989C7

Presca RJ45 cat 6 FTP autocrimpante
schermata
Self-crimping RJ45 socket cat 6 FTP

CONFEX BOX	6 pz
IMBALLO PACKAGE	120 pz



ECSE8981

Alimentatore USB tipo A da incasso
Aggancio Keystone
USB charger A type Keystone docking

CONFEX BOX	6 pz
IMBALLO PACKAGE	120 pz



Tensione alimentazione In:
100-240V~50/60Hz
Tensione alimentazione Out:
5Vdc 2.1A
Input: 100-240V~50/60Hz
Output: 5Vdc 2.1A



ECSE8981C

Alimentatore USB tipo C da incasso
Aggancio Keystone
USB charger C type Keystone docking

CONFEX BOX	6 pz
IMBALLO PACKAGE	120 pz



Tensione alimentazione In:
100-240V~50/60Hz
Tensione alimentazione Out:
5Vdc 2.1A
Input: 100-240V~50/60Hz
Output: 5Vdc 2.1A



ECSE8989

Presca standard USB aggancio Keystone
USB standard socket - Keystone docking

CONFEX BOX	6 pz
IMBALLO PACKAGE	120 pz



ECSE898901

Adattatore Keystone
connettore telefonia/dati
Keystone adapter
telephone/data connector

CONFEX BOX	32 pz
IMBALLO PACKAGE	640 pz



PRESE TV E SAT TELEVISION AND SATELLITE SOCKETS

Specifiche tecniche a pag. 125
Technical features page 125



ECL20483

Resistenza terminale
di chiusura linea prese TV
impedenza 75 Ohm
Terminal closing TV socket line
impedance 75 Ohm

CONFEX BOX	20 pz
------------	-------



ECSE81731

Presca coassiale TV
DIRETTA per impianti monoutenza
PASSANTE per impianti a cascata
TERMINATA con collegamento
all'art. ECL20483 per impianti a cascata

CONFEX BOX	12 pz
IMBALLO PACKAGE	240 pz



TV socket
DIRECT for single user system
PASSING for system with fall distribution
TERMINAL connected with art. ECL20483
for system with fall distribution

Connettore femmina D mm 9.5 Attenuazione di passaggio 0 dB VHF-UHF (40-860MHz)	Female connector D mm 9.5 Signal attenuation 0 dB VHF-UHF (40-860MHz)
--	---



ECSE81731M

Presca coassiale TV
DIRETTA per impianti monoutenza
PASSANTE per impianti a cascata
TERMINATA con collegamento
all'art. ECL20483 per impianti a cascata

CONFEX BOX	12 pz
IMBALLO PACKAGE	240 pz



TV socket
DIRECT for single user system
PASSING for system with fall distribution
TERMINAL connected with art. ECL20483
for system with fall distribution

Connettore maschio Attenuazione di passaggio 0 dB VHF-UHF (40-860MHz)	Male connector Signal attenuation 0 dB VHF-UHF (40-860MHz)
---	--



PRESE TV E SAT TELEVISION AND SATELLITE SOCKETS

Specifiche tecniche a pag. 125
Technical features page 125



ECSE8173D

Presse coassiale ULB diretta
Direct ULB socket

CONFEZ
BOX 12 pz
IMBALLO
PACKAGE 240 pz



Connettore maschio (CEI EN 61169-2)
Totalmente schermata
per impianti tradizionali e satellitari
Attenuazione 0 dB - 5-2400MHz - Classe A
Male connector (CEI EN 61169-2)
Totally shielded for TV and SAT systems
Signal attenuation 0 dB - 5-2400MHz - A class



ECSE8173P

Presse coassiale
ULB passante
Attenuazione 4 dB
Passing ULB socket
Signal attenuation 4 dB

CONFEZ
BOX 12 pz
IMBALLO
PACKAGE 240 pz



Connettore maschio (CEI EN 61169-2)
Totalmente schermata
per impianti tradizionali e satellitari
5-2400MHz - Classe A
Male connector (CEI EN 61169-2)
Totally shielded for TV and SAT systems
5-2400MHz - A class



ECSE8174P

Presse coassiale
ULB passante
Attenuazione 7 dB
Passing ULB socket
Signal attenuation 7 dB

CONFEZ
BOX 12 pz
IMBALLO
PACKAGE 240 pz



Connettore maschio (CEI EN 61169-2)
Totalmente schermata
per impianti tradizionali e satellitari
5-2400MHz - Classe A
Male connector (CEI EN 61169-2)
Totally shielded for TV and SAT systems
5-2400MHz - A class



ECSE8175P

Presse coassiale
ULB passante
Attenuazione 10 dB
Passing ULB socket
Signal attenuation 10 dB

CONFEZ
BOX 12 pz
IMBALLO
PACKAGE 240 pz



Connettore maschio (CEI EN 61169-2)
Totalmente schermata
per impianti tradizionali e satellitari
5-2400MHz - Classe A
Male connector (CEI EN 61169-2)
Totally shielded for TV and SAT systems
5-2400MHz - A class



ECSE8172D

Presse coassiale
TV SAT diretta
Direct TV/SAT socket

CONFEZ
BOX 12 pz
IMBALLO
PACKAGE 240 pz



Connettore femmina (IEC 60169-24)
Totalmente schermata
per impianti tradizionali e satellitari
Attenuazione 0 dB
TV-SAT (5-2400MHz) - Classe A
Female connector (IEC 60169-24)
Totally shielded for TV and SAT systems
Signal attenuation 0 dB
TV-SAT (5-2400MHz) - A class



ECSE8172P

Presse coassiale
TV SAT passante
Passing TV/SAT socket

CONFEZ
BOX 12 pz
IMBALLO
PACKAGE 240 pz



Connettore femmina (IEC 60169-24)
Totalmente schermata
per impianti tradizionali e satellitari
Attenuazione 4 dB
TV-SAT (5-2400MHz) - Classe A
Female connector (IEC 60169-24)
Totally shielded for TV and SAT systems
Signal attenuation 4 dB
TV-SAT (5-2400MHz) - A class



ECSE8173F

Presse coassiale SAT tipo F
TV/SAT socket F-type

CONFEZ
BOX 12 pz
IMBALLO
PACKAGE 240 pz



Connettore femmina (IEC 60169-24)
max 2400MHz
Female connector (IEC 60169-24)
max 2400MHz



ECSE8188

Presse standard HDMI aggancio Keystone
con 10 cm di cavo
HDMI standard socket - Keystone docking
with 10 cm cable

CONFEZ
BOX 6 pz
IMBALLO
PACKAGE 120 pz



APPARECCHI DI COMANDO SPECIALI SPECIAL DEVICES



ECSE8025

Pulsante con portanome
Name holder push button

CONFEZ
BOX 6 pz
IMBALLO
PACKAGE 120 pz



1P/NO 250V~



ECSE8050U

Interruttore unipolare con chiave unificata
Estrazione chiave in posizione ON e OFF
1 way single pole switch with unified key
Key extraction in ON and OFF position

CONFEZ
BOX 6 pz
IMBALLO
PACKAGE 120 pz



10A 250V~



ECSE8050UNE

Interruttore unipolare con chiave unificata
Estrazione chiave solo in OFF
1 way single pole switch with unified key
Key extraction only in OFF position

CONFEZ
BOX 6 pz
IMBALLO
PACKAGE 120 pz



10A 250V~

APPARECCHI DI SEGNALAZIONE ACUSTICA E LUMINOSA SOUND AND LIGHT SIGNALLING DEVICES



ECSE8031
Suoneria
Bell

CONFEX BOX	12 pz
IMBALLO PACKAGE	240 pz



12V~ 50Hz 8VA max

Funzionamento intermittente 5/15:
l'emissione sonora può durare
fino a 5s max, seguita da
un periodo di riposo di 15s.

*Intermittent sound 5/15:
the sound emission can last up
to max 5 seconds, followed by
a period at rest of 15 seconds.*

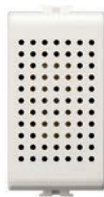

ECSE8041
Suoneria
Bell

CONFEX BOX	12 pz
IMBALLO PACKAGE	240 pz



220V~ 50Hz 8VA max

Funzionamento intermittente 5/15:
l'emissione sonora può durare
fino a 5s max, seguita da
un periodo di riposo di 15s.

*Intermittent sound 5/15:
the sound emission can last up
to max 5 seconds, followed by
a period at rest of 15 seconds.*



ECSE8045
Ronzatore
Buzzer

CONFEX BOX	12 pz
IMBALLO PACKAGE	240 pz



12V~ 50Hz 8VA max

Funzionamento intermittente 5/15:
l'emissione sonora può durare
fino a 5s max, seguita da
un periodo di riposo di 15s.

*Intermittent sound 5/15:
the sound emission can last up
to max 5 seconds, followed by
a period at rest of 15 seconds.*

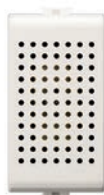

ECSE8048
Ronzatore
Buzzer

CONFEX BOX	12 pz
IMBALLO PACKAGE	240 pz



220V~ 50Hz 8VA max

Funzionamento intermittente 5/15:
l'emissione sonora può durare
fino a 5s max, seguita da
un periodo di riposo di 15s.

*Intermittent sound 5/15:
the sound emission can last up
to max 5 seconds, followed by
a period at rest of 15 seconds.*



ECSE80661
Diffusore notturno a LED
1 modulo aggancio Keystone
1 module LED night diffuser
Keystone docking

CONFEX BOX	6 pz
IMBALLO PACKAGE	30 pz



230V~ 50Hz

Lampada 1 LED colore bianco
Intensità luminosa:
> 1800 mcd @ 3.7mA
Funzioni: ON (SA) - AUTO (SE)
Temperatura di
funzionamento: -10° + 40°

*Bulb: 1 LED white colour
Brightness: > 1800 mcd @ 3.7mA
Function: ON (SA) - AUTO (SE)
Working temperature: -10° + 40°*



ECSE80671
Lampada di emergenza a LED
1 modulo aggancio Keystone
1 module LED emergency lamp
Keystone docking

CONFEX BOX	6 pz
IMBALLO PACKAGE	30 pz



230V~ 50Hz

Lampada 1 LED colore bianco
Intensità luminosa: > 5700 mcd @ 3.7mA
Funzioni: ON (SA) - AUTO (SE)
Temperatura di funzionamento: -10° + 40°
Autonomia: 2h - Tempo di ricarica: 3h circa

*Bulb: 1 LED white colour
Brightness: > 5700 mcd @ 3.7mA
Function: ON (SA) - AUTO (SE)
Working temperature: -10° + 40°
Autonomy: 2h - Recharge time: about 3h*

SUPPORTI A PARETE WALL FRAMES



ECSE801

Supporto internazionale 2 moduli
scatola quadrata interasse 71 mm
*Connectable international frame
2 modules - square box 71 mm wheelbase*

CONFEX
BOX 40 pz
IMBALLO
PACKAGE 480 pz



ECSE802

Supporto con zanche 2 moduli per scatola tonda diam. 60 mm
e scatola quadrata - interasse 71 mm
*Connectable international frame with staples 2 modules
for round box diam. 60 mm and square box 71 mm wheelbase*

CONFEX
BOX 25 pz
IMBALLO
PACKAGE 300 pz



ECSE803

Supporto 3 moduli con viti
aggancio frutti frontali
*3 modules frame with screws
front docking*

IMBALLO
PACKAGE 100 pz



ECSE804

Supporto 4 moduli con viti
aggancio frutti frontali
*4 modules frame with screws
front docking*

CONFEX
BOX 20 pz
IMBALLO
PACKAGE 160 pz

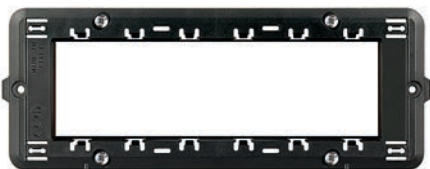

ECSE806

Supporto 6 moduli con viti
aggancio frutti frontali
*6 modules frame with screws
front docking*

CONFEX
BOX 10 pz
IMBALLO
PACKAGE 120 pz



VERSIONI DISPONIBILI AVAILABLE MODELS



2 MODULI* 2 MODULES*

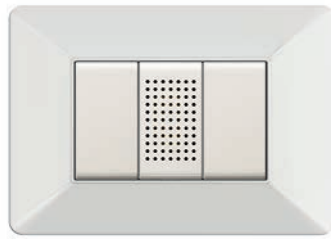

3 MODULI 3 MODULES



4 MODULI 4 MODULES



6 MODULI 6 MODULES

Per la pulizia delle placche Easy "FINITURE METALLICHE" utilizzare esclusivamente un panno asciutto senza aggiunta di nessun tipo di solvente (spray, ecc.), che potrebbe alterarne i colori. Le foto hanno puramente carattere di presentazione.

* Disponibile solo nelle finiture WH e A.

To clean EASY "METALLIC FINISHES" cover plates, use only a dry cloth without add any type of cleaning solvent that could alter its original colour.

* Only available in finishes WH and A.

FINITURE BASE BASIC FINISHES

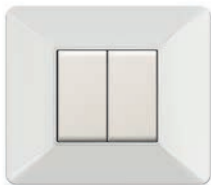

BIANCO WHITE

ECSE9802WH



2 MODULI MODULES

CONFEZ BOX 30 PZ

IMBALLO PACKAGE 360 PZ

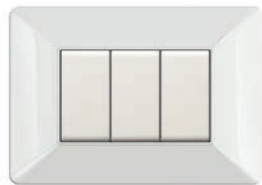

BIANCO WHITE

ECSE9803WH ECSE9804WH ECSE9806WH



3 MODULI MODULES

CONFEZ BOX 20 PZ

IMBALLO PACKAGE 240 PZ



4 MODULI MODULES

CONFEZ BOX 15 PZ

IMBALLO PACKAGE 180 PZ



6 MODULI MODULES

CONFEZ BOX 10 PZ

IMBALLO PACKAGE 120 PZ



AVORIO IVORY

ECSE9802A



2 MODULI MODULES

CONFEZ BOX 30 PZ

IMBALLO PACKAGE 360 PZ

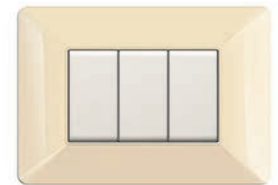

AVORIO IVORY

ECSE9803A ECSE9804A ECSE9806A



3 MODULI MODULES

CONFEZ BOX 20 PZ

IMBALLO PACKAGE 240 PZ



4 MODULI MODULES

CONFEZ BOX 15 PZ

IMBALLO PACKAGE 180 PZ



6 MODULI MODULES

CONFEZ BOX 10 PZ

IMBALLO PACKAGE 120 PZ



NERO BLACK

ECSE9803N ECSE9804N ECSE9806N



3 MODULI MODULES

CONFEZ BOX 20 PZ

IMBALLO PACKAGE 240 PZ



4 MODULI MODULES

CONFEZ BOX 15 PZ

IMBALLO PACKAGE 180 PZ



6 MODULI MODULES

CONFEZ BOX 10 PZ

IMBALLO PACKAGE 120 PZ



BLU BLUE

ECSE9803BL ECSE9804BL ECSE9806BL



3 MODULI MODULES

CONFEZ BOX 20 PZ

IMBALLO PACKAGE 240 PZ



4 MODULI MODULES

CONFEZ BOX 15 PZ

IMBALLO PACKAGE 180 PZ



6 MODULI MODULES

CONFEZ BOX 10 PZ

IMBALLO PACKAGE 120 PZ

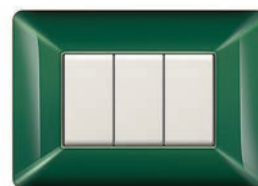

VERDE SCOZIA SCOTTISH GREEN

ECSE9803WH ECSE9804WH ECSE9806WH



3 MODULI MODULES

CONFEZ BOX 20 PZ

IMBALLO PACKAGE 240 PZ



4 MODULI MODULES

CONFEZ BOX 15 PZ

IMBALLO PACKAGE 180 PZ



6 MODULI MODULES

CONFEZ BOX 10 PZ

IMBALLO PACKAGE 120 PZ



AMARANTO BURGUNDY

ECSE9803WH ECSE9804WH ECSE9806WH



3 MODULI MODULES

CONFEZ BOX 20 PZ

IMBALLO PACKAGE 240 PZ



4 MODULI MODULES

CONFEZ BOX 15 PZ

IMBALLO PACKAGE 180 PZ



6 MODULI MODULES

CONFEZ BOX 10 PZ

IMBALLO PACKAGE 120 PZ

FINITURE PASTELLO PASTEL FINISHES

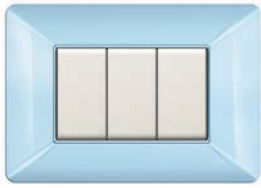

AZZURRO PASTELLO PASTEL AZURE

ECSE9803PA	ECSE9804PA	ECSE9806PA
3 MODULI MODULES	4 MODULI MODULES	6 MODULI MODULES
CONFEZ BOX 20 pz	CONFEZ BOX 15 pz	CONFEZ BOX 10 pz
IMBALLO PACKAGE 240 pz	IMBALLO PACKAGE 180 pz	IMBALLO PACKAGE 120 pz

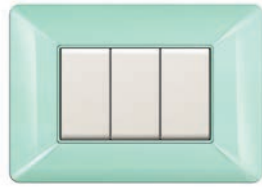

VERDE PASTELLO PASTEL GREEN

ECSE9803PG	ECSE9804PG	ECSE9806PG
3 MODULI MODULES	4 MODULI MODULES	6 MODULI MODULES
CONFEZ BOX 20 pz	CONFEZ BOX 15 pz	CONFEZ BOX 10 pz
IMBALLO PACKAGE 240 pz	IMBALLO PACKAGE 180 pz	IMBALLO PACKAGE 120 pz



GIALLO PASTELLO PASTEL YELLOW

ECSE9803PY	ECSE9804PY	ECSE9806PY
3 MODULI MODULES	4 MODULI MODULES	6 MODULI MODULES
CONFEZ BOX 20 pz	CONFEZ BOX 15 pz	CONFEZ BOX 10 pz
IMBALLO PACKAGE 240 pz	IMBALLO PACKAGE 180 pz	IMBALLO PACKAGE 120 pz

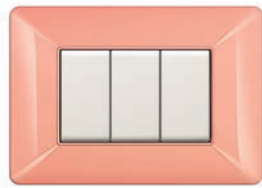

ARANCIO PASTELLO PASTEL ORANGE

ECSE9803PO	ECSE9804PO	ECSE9806PO
3 MODULI MODULES	4 MODULI MODULES	6 MODULI MODULES
CONFEZ BOX 20 pz	CONFEZ BOX 15 pz	CONFEZ BOX 10 pz
IMBALLO PACKAGE 240 pz	IMBALLO PACKAGE 180 pz	IMBALLO PACKAGE 120 pz

FINITURE METALLICHE METALLIC FINISHES

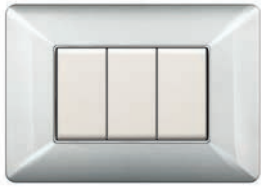

ALLUMINIO CHIARO LIGHT ALUMINUM

ECSE9803AC	ECSE9804AC	ECSE9806AC
3 MODULI MODULES	4 MODULI MODULES	6 MODULI MODULES
CONFEZ BOX 20 pz	CONFEZ BOX 15 pz	CONFEZ BOX 10 pz
IMBALLO PACKAGE 240 pz	IMBALLO PACKAGE 180 pz	IMBALLO PACKAGE 120 pz



ALLUMINIO NOTTE DARK ALUMINUM

ECSE9803AN	ECSE9804AN	ECSE9806AN
3 MODULI MODULES	4 MODULI MODULES	6 MODULI MODULES
CONFEZ BOX 20 pz	CONFEZ BOX 15 pz	CONFEZ BOX 10 pz
IMBALLO PACKAGE 240 pz	IMBALLO PACKAGE 180 pz	IMBALLO PACKAGE 120 pz



ACCIAIO SATINATO SATIN STEEL

ECSE9803AS	ECSE9804AS	ECSE9806AS
3 MODULI MODULES	4 MODULI MODULES	6 MODULI MODULES
CONFEZ BOX 20 pz	CONFEZ BOX 15 pz	CONFEZ BOX 10 pz
IMBALLO PACKAGE 240 pz	IMBALLO PACKAGE 180 pz	IMBALLO PACKAGE 120 pz



CROMO CHROME

ECSE9803CR	ECSE9804CR	ECSE9806CR
3 MODULI MODULES	4 MODULI MODULES	6 MODULI MODULES
CONFEZ BOX 20 pz	CONFEZ BOX 15 pz	CONFEZ BOX 10 pz
IMBALLO PACKAGE 240 pz	IMBALLO PACKAGE 180 pz	IMBALLO PACKAGE 120 pz



ORO GOLD

ECSE9803OR	ECSE9804OR	ECSE9806OR
3 MODULI MODULES	4 MODULI MODULES	6 MODULI MODULES
CONFEZ BOX 20 pz	CONFEZ BOX 15 pz	CONFEZ BOX 10 pz
IMBALLO PACKAGE 240 pz	IMBALLO PACKAGE 180 pz	IMBALLO PACKAGE 120 pz



SABBIA ORO GOLD SAND

ECSE9803SO	ECSE9804SO	ECSE9806SO
3 MODULI MODULES	4 MODULI MODULES	6 MODULI MODULES
CONFEZ BOX 20 pz	CONFEZ BOX 15 pz	CONFEZ BOX 10 pz
IMBALLO PACKAGE 240 pz	IMBALLO PACKAGE 180 pz	IMBALLO PACKAGE 120 pz

FINITURE VULCANIZZATE VULCANISED FINISHES



GRIGIO NOTTE DARK GREY

ECSE9803V-GN ECSE9804V-GN ECSE9806V-GN

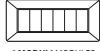

3 MODULI MODULES		4 MODULI MODULES		6 MODULI MODULES	
CONFZ BOX	20 pz	CONFZ BOX	15 pz	CONFZ BOX	10 pz
IMBALLO PACKAGE	240 pz	IMBALLO PACKAGE	180 pz	IMBALLO PACKAGE	120 pz



GRIGIO CHIARO LIGHT GREY

ECSE9803V-GC ECSE9804V-GC ECSE9806V-GC

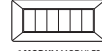

3 MODULI MODULES		4 MODULI MODULES		6 MODULI MODULES	
CONFZ BOX	20 pz	CONFZ BOX	15 pz	CONFZ BOX	10 pz
IMBALLO PACKAGE	240 pz	IMBALLO PACKAGE	180 pz	IMBALLO PACKAGE	120 pz

FINITURE LEGNO WOODEN-LIKE FINISHES

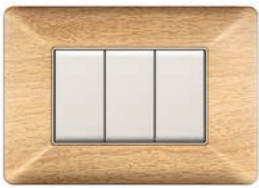

BETULLA BIRCH

ECSE9803BT ECSE9804BT ECSE9806BT



3 MODULI MODULES		4 MODULI MODULES		6 MODULI MODULES	
CONFZ BOX	20 pz	CONFZ BOX	15 pz	CONFZ BOX	10 pz
IMBALLO PACKAGE	240 pz	IMBALLO PACKAGE	180 pz	IMBALLO PACKAGE	120 pz



LEGNO CHIARO LIGHT WOOD

ECSE9803LC ECSE9804LC ECSE9806LC

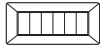

3 MODULI MODULES		4 MODULI MODULES		6 MODULI MODULES	
CONFZ BOX	20 pz	CONFZ BOX	15 pz	CONFZ BOX	10 pz
IMBALLO PACKAGE	240 pz	IMBALLO PACKAGE	180 pz	IMBALLO PACKAGE	120 pz



LEGNO SCURO DARK WOOD

ECSE9803LS ECSE9804LS ECSE9806LS

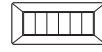

3 MODULI MODULES		4 MODULI MODULES		6 MODULI MODULES	
CONFZ BOX	20 pz	CONFZ BOX	15 pz	CONFZ BOX	10 pz
IMBALLO PACKAGE	240 pz	IMBALLO PACKAGE	180 pz	IMBALLO PACKAGE	120 pz

CONTENITORI DA PARETE SERIE SE6040 - IP40 SE6040 SERIES - IP40 WALL MOUNTING BOXES



ECSE60401
Contenitore da parete per 1 apparecchio EASY
Wall box for 1 EASY electrical device

CONFZ BOX 1 pz IP 40
IMBALLO PACKAGE 60 pz Grigio/Grey RAL 7035
Dimensioni/Size: 76,5x76,5x56,5 mm



ECSE60402
Contenitore da parete per 2 apparecchi EASY
Wall box for 2 EASY electrical devices

CONFZ BOX 1 pz IP 40
IMBALLO PACKAGE 60 pz Grigio/Grey RAL 7035
Dimensioni/Size: 76,5x76,5x56,5 mm



ECSE60403
Contenitore da parete per 3 apparecchi EASY
Wall box for 3 EASY electrical devices

CONFZ BOX 1 pz IP 40
IMBALLO PACKAGE 40 pz Grigio/Grey RAL 7035
Dimensioni/Size: 101x76,5x56,5 mm



ECSE60404
Contenitore da parete per 4 apparecchi EASY
Wall box for 4 EASY electrical devices

CONFZ BOX 1 pz IP 40
IMBALLO PACKAGE 30 pz Grigio/Grey RAL 7035
Dimensioni/Size: 125,5x76,5x56,5 mm



CONTENITORI DA PARETE CON PORTELLO SERIE SE6050 - IP55 SE6050 SERIES - IP55 WALL MOUNTING BOXES WITH HATCH



ECSE60501
Contenitore da parete con portello per 1 apparecchio EASY
Wall box with hatch for 1 EASY electrical device

CONFZ BOX 1 pz IP 55
IMBALLO PACKAGE 50 pz Grigio/Grey RAL 7035
Dimensioni/Size: 76,5x76,5x64,5 mm



ECSE60502
Contenitore da parete con portello per 2 apparecchi EASY
Wall box with hatch for 2 EASY electrical devices

CONFZ BOX 1 pz IP 55
IMBALLO PACKAGE 50 pz Grigio/Grey RAL 7035
Dimensioni/Size: 76,5x76,5x64,5 mm



ECSE60503
Contenitore da parete con portello per 3 apparecchi EASY
Wall box with hatch for 3 EASY electrical devices

CONFZ BOX 1 pz IP 55
IMBALLO PACKAGE 35 pz Grigio/Grey RAL 7035
Dimensioni/Size: 101x76,5x64,5 mm



ECSE60504
Contenitore da parete con portello per 4 apparecchi EASY
Wall box with hatch for 4 EASY electrical devices

CONFZ BOX 1 pz IP 55
IMBALLO PACKAGE 25 pz Grigio/Grey RAL 7035
Dimensioni/Size: 125,5x76,5x64,5 mm



CONTENITORI SPECIALI SPECIAL DISTRIBUTION BOARD BOXES



ECSE60400
Mini scatola per 2 apparecchi o per 1 apparecchio Schuko EASY pretranciato per minicanalina
Wall box for 2 or 1 Schuko EASY electrical devices equipped for installation on minitrunking

CONFZ BOX 1 pz IP 40
IMBALLO PACKAGE 30 pz Bianco/White RAL 9001
Dimensioni/Size: 56x58x51 mm



PLACCHE AUTOPORTANTI CON PORTELLO SELF-SUPPORTING PLATES WITH HATCH



ECSE60500B
Placca autoportante con portello per 3 apparecchi EASY
Self-supporting plate with hatch for 3 EASY electrical devices

CONFZ BOX 1 pz IP 55
IMBALLO PACKAGE 50 pz Bianco/White RAL 9001
Dimensioni/Size: 130x85x24 mm



ECSE60500G
Placca autoportante con portello per 3 apparecchi EASY
Self-supporting plate with hatch for 3 EASY electrical devices

CONFZ BOX 1 pz IP 55
IMBALLO PACKAGE 50 pz Grigio/Grey RAL 7035
Dimensioni/Size: 130x85x24 mm



ECSE605004B
Placca autoportante con portello per 4 apparecchi EASY
Self-supporting plate with hatch for 4 EASY electrical devices

CONFZ BOX 1 pz IP 55
IMBALLO PACKAGE 35 pz Bianco/White RAL 9001
Dimensioni/Size: 154x85x26 mm



ECSE605004G
Placca autoportante con portello per 4 apparecchi EASY
Self-supporting plate with hatch for 4 EASY electrical devices

CONFZ BOX 1 pz IP 55
IMBALLO PACKAGE 25 pz Grigio/Grey RAL 7035
Dimensioni/Size: 154x85x26 mm





Tondò®

Apparecchi modulari e placche coprinterruttori

Gli apparecchi modulari TONDÒ® sono un classico nell'ambito del residenziale di base e dell'edilizia pubblica. Resistenti e versatili, con circa 27 funzioni modulari fanno della razionalità il proprio valore aggiunto. L'estrema praticità del sistema di fissaggio a scatto e la compatibilità con altre serie storiche dagli standard simili sono gli elementi chiave del successo di TONDÒ®. Le placche TONDÒ® sono disponibili in 15 colori suddivisi tra 5 finiture diverse. Eccezionale robustezza e facile installazione, dal design rinnovato e fluente, TONDÒ® si rivela come la soluzione completa creata per integrarsi in tutti gli ambienti ad un costo decisamente contenuto.

Modular devices and cover plates

TONDÒ® modular devices are very used as a classic line in range of basic residential and public building. Resistant and well-rounded, with 27 modular functions, they make rationality their surplus value. Easy fastening system and compatibility with other series with similar standard are the key elements of TONDÒ® success. TONDÒ® cover plates are available in 15 colours divided into 5 different finishes. Great resilience easy fastening, with a renewed and flowing design, TONDÒ® is a complete solution created for integrating in each type of places with a low prices.



APPARECCHI DI COMANDO BASE BASIC SWITCHING DEVICES



ECL2500

Interruttore unipolare
1 way single pole switch

CONFEZ.
BOX 20 pz
IMBALLO
PACKAGE 200 pz



16AX 250V~



ECL2503

Deviatore unipolare
2 way single pole switch

CONFEZ.
BOX 20 pz
IMBALLO
PACKAGE 200 pz



16AX 250V~



ECL2506

Invertitore unipolare
Intermediate single pole switch

CONFEZ.
BOX 20 pz
IMBALLO
PACKAGE 200 pz



16AX 250V~



ECL2509

Interruttore bipolare
1 way double pole switch

CONFEZ.
BOX 20 pz
IMBALLO
PACKAGE 200 pz



16AX 250V~



ECL2521

Pulsante unipolare generico
Push button

CONFEZ.
BOX 20 pz
IMBALLO
PACKAGE 200 pz



10A 250V~ 1P/NO



ECL2524

Pulsante unipolare a tirante
Push button with cord

CONFEZ.
BOX 10 pz
IMBALLO
PACKAGE 100 pz



Lunghezza cordino 1,5 m
Cord lenght 1,5 m
10A 250V~ 1P/NO

Per avere le versioni illuminabili degli apparecchi TONDÒ® basta acquistare ed installare la lampadina art. ECL4000 LN/LD/LD12 (pag.10).

To have lightable version of TONDÒ® modular devices is necessary buying and installing the indicator lamp art.ECL4000 LN/LD/LD12 (pag 10).

Per l'installazione specifiche tecniche a pag. 119
For installation technical features page 119

PRESE DI CORRENTE OUTLET SOCKETS



ECL2539

Preso italiana con sicurezza
Italian shuttered socket

CONFEZ.
BOX 20 pz
IMBALLO
PACKAGE 200 pz



10A 250V~
2P + ⊕
Standard P11



ECL2545

Preso italiana bivalente con sicurezza
Italian double shuttered socket

CONFEZ.
BOX 20 pz
IMBALLO
PACKAGE 200 pz



10/16A 250V~
2P + ⊕
Standard P17/P11



ECL2550

Preso italiana/tedesca trivalente con sicurezza
2 moduli
Italian/German triple shuttered socket
2 modules

CONFEZ.
BOX 10 pz
IMBALLO
PACKAGE 100 pz



10/16A 250V~
2P + ⊕ centrale/central
Standard P40



ECL2538

Preso euroamericana
Euroamerican socket

CONFEZ.
BOX 20 pz
IMBALLO
PACKAGE 200 pz



16A 127/250V~
2P

PRESE TELEFONICHE E TRASMISSIONE DATI TELEPHONE AND DATA SOCKETS

Specifiche tecniche a pag. 122, 123, 124
Technical features page 122, 123, 124



ECL2584

Presca telefonica RJ11 plug 6/4
RJ12 plug 6/6 autocrimpante
Self-crimping telephone socket
RJ11 plug 6/4 RJ12 plug 6/6

CONFEZ.	
BOX	10 pz
IMBALLO	
PACKAGE	100 pz



ECL2583

Presca RJ45 cat 5e UTP
non schermata autocrimpante
self-crimping RJ45 socket cat 5e UTP

CONFEZ.	
BOX	10 pz
IMBALLO	
PACKAGE	100 pz



ECL2585

Presca RJ45 cat 5e FTP
schermata autocrimpante
self-crimping RJ45 socket cat 5e FTP

CONFEZ.	
BOX	10 pz
IMBALLO	
PACKAGE	100 pz



ECL2587

Presca RJ45 cat 6 UTP
non schermata autocrimpante
self-crimping RJ45 socket cat 6 UTP

CONFEZ.	
BOX	10 pz
IMBALLO	
PACKAGE	100 pz



ECL2586

Presca RJ45 cat 6 FTP
schermata autocrimpante
self-crimping RJ45 socket cat 6 FTP

CONFEZ.	
BOX	10 pz
IMBALLO	
PACKAGE	100 pz



PRESE TV E SAT TELEVISION AND SATELLITE SOCKETS

Specifiche tecniche a pag. 125
Technical features page 125



ECL2048 3

Resistenza terminale
di chiusura linea prese TV
impedenza 75 Ohm
Terminal closing TV socket line
impedance 75 Ohm

CONFEZ.	
BOX	20 pz



ECL2548 1

Presca coassiale TV
DIRETTA per impianti monoutenza
PASSANTE per impianti a cascata
TERMINATA con collegamento
all'art. ECL20483 per impianti a cascata

CONFEZ.	
BOX	20 pz
IMBALLO	
PACKAGE	200 pz



TV socket
DIRECT for single user system
PASSING for system with fall distribution
TERMINAL connected with art. ECL20483
for system with fall distribution

Connettore femmina D mm 9,5 Attenuazione di passaggio 0 dB VHF-UHF (40-860MHz)	Female connector D mm 9,5 Signal attenuation 0 dB VHF-UHF (40-860MHz)
--	---



ECL2548 1M

Presca coassiale TV
DIRETTA per impianti monoutenza
PASSANTE per impianti a cascata
TERMINATA con collegamento
all'art. ECL20483 per impianti a cascata

CONFEZ.	
BOX	20 pz
IMBALLO	
PACKAGE	200 pz



TV socket
DIRECT for single user system
PASSING for system with fall distribution
TERMINAL connected with art. ECL20483
for system with fall distribution

Connettore maschio Attenuazione di passaggio 0 dB VHF-UHF (40-860MHz)	Male connector Signal attenuation 0 dB VHF-UHF (40-860MHz)
---	--



Specifiche tecniche a pag. 125
Technical features page 125



ECL2551

Presca coassiale ULB diretta
Direct ULB socket

CONFEZ.	
BOX	20 pz
IMBALLO	
PACKAGE	200 pz



Connettore maschio (CEI EN 61169-2)
Totalmente schermata
per impianti tradizionali e satellitari
Attenuazione 0 dB - 5-2400MHz - Classe A
Male connector (CEI EN 61169-2)
Totally shielded for TV and SAT systems
Signal attenuation 0 dB - 5-2400MHz - A class



ECL2552 SAT

Presca coassiale TV SAT diretta
Direct TV SAT socket

CONFEZ.	
BOX	20 pz
IMBALLO	
PACKAGE	200 pz



Connettore femmina (IEC 60169-24)
Totalmente schermata per impianti tradizionali e satellitari
Attenuazione 0 dB - TV-SAT (5-2400MHz) - Classe A
Female connector (IEC 60169-24)
Totally shielded for TV and SAT systems
Signal attenuation 0 dB - TV-SAT (5-2400MHz) - A class



ECL2553 SAT

Presca coassiale SAT tipo F
TV SAT socket F-type

CONFEZ.	
BOX	20 pz
IMBALLO	
PACKAGE	200 pz



Connettore femmina (IEC 60169-24)
max 2400MHz
Female connector (IEC 60169-24)
max 2400MHz

APPARECCHI DI COMANDO ELETTRONICI ELECTRONIC DEVICES

Specifiche tecniche a pag. 129
Technical features page 129



ECL2701

Variatore di luminosità con deviatore push-push per carichi resistivi con punto luminoso rosso per individuazione al buio
Resistive light dimmer with 2 way single pole switch. Push action. Red indicator light in the front side

CONFEZ. BOX 4 pz
IMBALLO PACKAGE 40 pz



100-500W 230V~

APPARECCHI DI SEGNALAZIONE ACUSTICA E LUMINOSA SOUND AND LIGHT SIGNALLING DEVICES



ECL2572 1

12V~ 50Hz 8VA max



Suoneria
Bell
Funzionamento intermittente 5/15:
l'emissione sonora può durare fino a 5s max, seguita da un periodo di riposo di 15s.

CONFEZ. BOX 20 pz
IMBALLO PACKAGE 200 pz
Intermittent sound 5/15:
the sound emission can last up to max 5 seconds, followed by a period at rest of 15 seconds.



ECL2572 10

220V~ 50Hz 8VA max



Suoneria
Bell
Funzionamento intermittente 5/15:
l'emissione sonora può durare fino a 5s max, seguita da un periodo di riposo di 15s.

CONFEZ. BOX 20 pz
IMBALLO PACKAGE 200 pz
Intermittent sound 5/15:
the sound emission can last up to max 5 seconds, followed by a period at rest of 15 seconds.

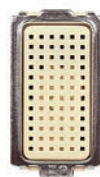

ECL2575 1

12V~ 50Hz 8VA max



Ronzatore
Buzzer
Funzionamento intermittente 5/15:
l'emissione sonora può durare fino a 5s max, seguita da un periodo di riposo di 15s.

CONFEZ. BOX 20 pz
IMBALLO PACKAGE 200 pz
Intermittent sound 5/15:
the sound emission can last up to max 5 seconds, followed by a period at rest of 15 seconds.



ECL2575 10

220V~ 50Hz 8VA max



Ronzatore
Buzzer
Funzionamento intermittente 5/15:
l'emissione sonora può durare fino a 5s max, seguita da un periodo di riposo di 15s.

CONFEZ. BOX 20 pz
IMBALLO PACKAGE 200 pz
Intermittent sound 5/15:
the sound emission can last up to max 5 seconds, followed by a period at rest of 15 seconds.



ECL2527

Spia luminosa rossa
Red pilot light

CONFEZ. BOX 20 pz
IMBALLO PACKAGE 200 pz



230V~ 1,5mA

COPRITASTO 1 MODULO 1 MODULE COVER



ECL2580

Falso polo
Blank cap

CONFEZ. BOX 100 pz
IMBALLO PACKAGE 1000 pz



SUPPORTI A PARETE PER SERIE TONDÒ® WALL FRAMES FOR TONDÒ® SERIES



ECL99TP

Supporto 3 moduli
3 modules frame

IMBALLO
PACKAGE 100 pz



ECL100TP

Supporto per UNEL centrata
Frame for UNEL central socket

CONFEZ.
BOX 25 pz
IMBALLO
PACKAGE 200 pz



ECL101TP

Supporto per UNEL decentrata + 1 modulo
Frame for UNEL side socket + 1 module

CONFEZ.
BOX 25 pz
IMBALLO
PACKAGE 200 pz

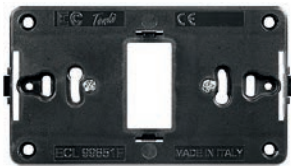

ECL9965 1F

Supporto 1 modulo per scatola tonda
Frame for round box 1 module

CONFEZ.
BOX 25 pz
IMBALLO
PACKAGE 200 pz



ECL9965 2F

Supporto 2 moduli per scatola tonda
Frame for round box 2 modules

CONFEZ.
BOX 25 pz
IMBALLO
PACKAGE 200 pz



VERSIONI DISPONIBILI AVAILABLE MODELS



1 MODULO 1 MODULE



2 MODULI 2 MODULES



3 MODULI 3 MODULES



4 MODULI 4 MODULES



6 MODULI 6 MODULES



2 MODULI RAVVICINATI
2 MODULES NEARED



PER UNEL DECENTRATA
FOR UNEL SIDE SOCKET



PER UNEL CENTRATA
FOR UNEL CENTRAL SOCKET

FINITURE BASE BASIC FINISHES



BIANCO WHITE CE



AVORIO IVORY CE



NERO BLACK CE

ECL2591 WH ECL2592 WH ECL2593 WH



1 MODULO MODULE	2 MODULI MODULES	3 MODULI MODULES
CONF. BOX 25 pz	CONF. BOX 25 pz	CONF. BOX 25 pz
IMBALLO PACKAGE 400 pz	IMBALLO PACKAGE 400 pz	IMBALLO PACKAGE 400 pz

ECL2591 A ECL2592 A ECL2593 A



1 MODULO MODULE	2 MODULI MODULES	3 MODULI MODULES
CONF. BOX 25 pz	CONF. BOX 25 pz	CONF. BOX 25 pz
IMBALLO PACKAGE 400 pz	IMBALLO PACKAGE 400 pz	IMBALLO PACKAGE 400 pz

ECL2591 N ECL2592 N ECL2593 N



1 MODULO MODULE	2 MODULI MODULES	3 MODULI MODULES
CONF. BOX 25 pz	CONF. BOX 25 pz	CONF. BOX 25 pz
IMBALLO PACKAGE 400 pz	IMBALLO PACKAGE 400 pz	IMBALLO PACKAGE 400 pz

ECL2594 WH ECL2596 WH



4 MODULI MODULES	6 MODULI MODULES
CONF. BOX 15 pz	CONF. BOX 15 pz
IMBALLO PACKAGE 240 pz	IMBALLO PACKAGE 240 pz

ECL2594 A ECL2596 A



4 MODULI MODULES	6 MODULI MODULES
CONF. BOX 15 pz	CONF. BOX 15 pz
IMBALLO PACKAGE 240 pz	IMBALLO PACKAGE 240 pz

ECL2594 N ECL2596 N

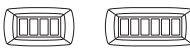

4 MODULI MODULES	6 MODULI MODULES
CONF. BOX 15 pz	CONF. BOX 15 pz
IMBALLO PACKAGE 240 pz	IMBALLO PACKAGE 240 pz

ECL2597 WH ECL2598 WH ECL2599 WH



2 MODULI RAVVICINATI	2 MODULI NEARED	PER UNEL DECENTRATA	FOR UNEL SIDE SOCKET	PER UNEL CENTRATA	FOR UNEL CENTRAL SOCKET
CONF. BOX 25 pz	CONF. BOX 25 pz	CONF. BOX 25 pz	CONF. BOX 25 pz	CONF. BOX 25 pz	CONF. BOX 25 pz
IMBALLO PACKAGE 400 pz	IMBALLO PACKAGE 400 pz	IMBALLO PACKAGE 400 pz	IMBALLO PACKAGE 400 pz	IMBALLO PACKAGE 400 pz	IMBALLO PACKAGE 400 pz

ECL2597 A ECL2598 A ECL2599 A



2 MODULI RAVVICINATI	2 MODULI NEARED	PER UNEL DECENTRATA	FOR UNEL SIDE SOCKET	PER UNEL CENTRATA	FOR UNEL CENTRAL SOCKET
CONF. BOX 25 pz	CONF. BOX 25 pz	CONF. BOX 25 pz	CONF. BOX 25 pz	CONF. BOX 25 pz	CONF. BOX 25 pz
IMBALLO PACKAGE 400 pz	IMBALLO PACKAGE 400 pz	IMBALLO PACKAGE 400 pz	IMBALLO PACKAGE 400 pz	IMBALLO PACKAGE 400 pz	IMBALLO PACKAGE 400 pz

ECL2597 N ECL2598 N ECL2599 N

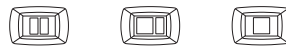

2 MODULI RAVVICINATI	2 MODULI NEARED	PER UNEL DECENTRATA	FOR UNEL SIDE SOCKET	PER UNEL CENTRATA	FOR UNEL CENTRAL SOCKET
CONF. BOX 25 pz	CONF. BOX 25 pz	CONF. BOX 25 pz	CONF. BOX 25 pz	CONF. BOX 25 pz	CONF. BOX 25 pz
IMBALLO PACKAGE 400 pz	IMBALLO PACKAGE 400 pz	IMBALLO PACKAGE 400 pz	IMBALLO PACKAGE 400 pz	IMBALLO PACKAGE 400 pz	IMBALLO PACKAGE 400 pz

FINITURE PASTELLO PASTEL FINISHES



AZZURRO PASTELLO PASTEL AZURE **CE**

ECL2591 PA	ECL2592 PA	ECL2593 PA
1 MODULO MODULE	2 MODULI MODULES	3 MODULI MODULES
CONF. BOX 25 pz	CONF. BOX 25 pz	CONF. BOX 25 pz
IMBALLO PACKAGE 400 pz	IMBALLO PACKAGE 400 pz	IMBALLO PACKAGE 400 pz



VERDE PASTELLO PASTEL GREEN **CE**

ECL2591 PG	ECL2592 PG	ECL2593 PG
1 MODULO MODULE	2 MODULI MODULES	3 MODULI MODULES
CONF. BOX 25 pz	CONF. BOX 25 pz	CONF. BOX 25 pz
IMBALLO PACKAGE 400 pz	IMBALLO PACKAGE 400 pz	IMBALLO PACKAGE 400 pz



GIALLO PASTELLO PASTEL YELLOW **CE**

ECL2591 PY	ECL2592 PY	ECL2593 PY
1 MODULO MODULE	2 MODULI MODULES	3 MODULI MODULES
CONF. BOX 25 pz	CONF. BOX 25 pz	CONF. BOX 25 pz
IMBALLO PACKAGE 400 pz	IMBALLO PACKAGE 400 pz	IMBALLO PACKAGE 400 pz



ARANCIO PASTELLO PASTEL ORANGE **CE**

ECL2591 PO	ECL2592 PO	ECL2593 PO
1 MODULO MODULE	2 MODULI MODULES	3 MODULI MODULES
CONF. BOX 25 pz	CONF. BOX 25 pz	CONF. BOX 25 pz
IMBALLO PACKAGE 400 pz	IMBALLO PACKAGE 400 pz	IMBALLO PACKAGE 400 pz

ECL2594 PA	ECL2596 PA
4 MODULI MODULES	6 MODULI MODULES
CONF. BOX 15 pz	CONF. BOX 15 pz
IMBALLO PACKAGE 240 pz	IMBALLO PACKAGE 240 pz

ECL2594 PG	ECL2596 PG
4 MODULI MODULES	6 MODULI MODULES
CONF. BOX 15 pz	CONF. BOX 15 pz
IMBALLO PACKAGE 240 pz	IMBALLO PACKAGE 240 pz

ECL2594 PY	ECL2596 PY
4 MODULI MODULES	6 MODULI MODULES
CONF. BOX 15 pz	CONF. BOX 15 pz
IMBALLO PACKAGE 240 pz	IMBALLO PACKAGE 240 pz

ECL2594 PO	ECL2596 PO
4 MODULI MODULES	6 MODULI MODULES
CONF. BOX 15 pz	CONF. BOX 15 pz
IMBALLO PACKAGE 240 pz	IMBALLO PACKAGE 240 pz

ECL2597 PA	ECL2598 PA	ECL2599 PA
2 MODULI MODULES	2 MODULI MODULES	2 MODULI MODULES
CONF. BOX 25 pz	CONF. BOX 25 pz	CONF. BOX 25 pz
IMBALLO PACKAGE 400 pz	IMBALLO PACKAGE 400 pz	IMBALLO PACKAGE 400 pz

ECL2597 PG	ECL2598 PG	ECL2599 PG
2 MODULI MODULES	2 MODULI MODULES	2 MODULI MODULES
CONF. BOX 25 pz	CONF. BOX 25 pz	CONF. BOX 25 pz
IMBALLO PACKAGE 400 pz	IMBALLO PACKAGE 400 pz	IMBALLO PACKAGE 400 pz

ECL2597 PY	ECL2598 PY	ECL2599 PY
2 MODULI MODULES	2 MODULI MODULES	2 MODULI MODULES
CONF. BOX 25 pz	CONF. BOX 25 pz	CONF. BOX 25 pz
IMBALLO PACKAGE 400 pz	IMBALLO PACKAGE 400 pz	IMBALLO PACKAGE 400 pz

ECL2597 PO	ECL2598 PO	ECL2599 PO
2 MODULI MODULES	2 MODULI MODULES	2 MODULI MODULES
CONF. BOX 25 pz	CONF. BOX 25 pz	CONF. BOX 25 pz
IMBALLO PACKAGE 400 pz	IMBALLO PACKAGE 400 pz	IMBALLO PACKAGE 400 pz

FINITURE METALLICHE METALLIC FINISHES



ORO GOLD **CE**

ECL2591 OR	ECL2592 OR	ECL2593 OR
1 MODULO MODULE	2 MODULI MODULES	3 MODULI MODULES
CONF. BOX 25 pz	CONF. BOX 25 pz	CONF. BOX 25 pz
IMBALLO PACKAGE 400 pz	IMBALLO PACKAGE 400 pz	IMBALLO PACKAGE 400 pz

ECL2591 AN	ECL2592 AN	ECL2593 AN
1 MODULO MODULE	2 MODULI MODULES	3 MODULI MODULES
CONF. BOX 25 pz	CONF. BOX 25 pz	CONF. BOX 25 pz
IMBALLO PACKAGE 400 pz	IMBALLO PACKAGE 400 pz	IMBALLO PACKAGE 400 pz

ECL2594 OR	ECL2596 OR
4 MODULI MODULES	6 MODULI MODULES
CONF. BOX 15 pz	CONF. BOX 15 pz
IMBALLO PACKAGE 240 pz	IMBALLO PACKAGE 240 pz

ECL2594 AN	ECL2596 AN
4 MODULI MODULES	6 MODULI MODULES
CONF. BOX 15 pz	CONF. BOX 15 pz
IMBALLO PACKAGE 240 pz	IMBALLO PACKAGE 240 pz

ECL2597 OR	ECL2598 OR	ECL2599 OR
2 MODULI MODULES	2 MODULI MODULES	2 MODULI MODULES
CONF. BOX 25 pz	CONF. BOX 25 pz	CONF. BOX 25 pz
IMBALLO PACKAGE 400 pz	IMBALLO PACKAGE 400 pz	IMBALLO PACKAGE 400 pz

ECL2597 AN	ECL2598 AN	ECL2599 AN
2 MODULI MODULES	2 MODULI MODULES	2 MODULI MODULES
CONF. BOX 25 pz	CONF. BOX 25 pz	CONF. BOX 25 pz
IMBALLO PACKAGE 400 pz	IMBALLO PACKAGE 400 pz	IMBALLO PACKAGE 400 pz

FINITURE VULCANIZZATE VULCANISED FINISHES



GRIGIO NOTTE DARK GREY

ECL2591 V-GN ECL2592 V-GN ECL2593 V-GN

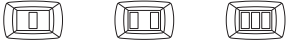

1 MODULO MODULE	2 MODULI MODULES	3 MODULI MODULES
CONF. BOX 25 pz	CONF. BOX 25 pz	CONF. BOX 25 pz
IMBALLO PACKAGE 400 pz	IMBALLO PACKAGE 400 pz	IMBALLO PACKAGE 400 pz



GRIGIO CHIARO LIGHT GREY

ECL2591 V-GC ECL2592 V-GC ECL2593 V-GC



1 MODULO MODULE	2 MODULI MODULES	3 MODULI MODULES
CONF. BOX 25 pz	CONF. BOX 25 pz	CONF. BOX 25 pz
IMBALLO PACKAGE 400 pz	IMBALLO PACKAGE 400 pz	IMBALLO PACKAGE 400 pz

ECL2594 V-GN ECL2596 V-GN

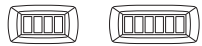

4 MODULI MODULES	6 MODULI MODULES
CONF. BOX 15 pz	CONF. BOX 15 pz
IMBALLO PACKAGE 240 pz	IMBALLO PACKAGE 240 pz

ECL2594 V-GC ECL2596 V-GC



4 MODULI MODULES	6 MODULI MODULES
CONF. BOX 15 pz	CONF. BOX 15 pz
IMBALLO PACKAGE 240 pz	IMBALLO PACKAGE 240 pz

ECL2597 V-GN ECL2598 V-GN ECL2599 V-GN

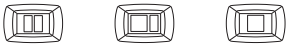

2 MODULI RAVVICINATI NEARED	PER UNEL DECENTRATA FOR UNEL SIDE SOCKET	PER UNEL CENTRATA FOR UNEL CENTRAL SOCKET
CONF. BOX 25 pz	CONF. BOX 25 pz	CONF. BOX 25 pz
IMBALLO PACKAGE 400 pz	IMBALLO PACKAGE 400 pz	IMBALLO PACKAGE 400 pz

ECL2597 V-GC ECL2598 V-GC ECL2599 V-GC

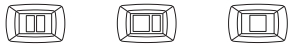

2 MODULI RAVVICINATI NEARED	PER UNEL DECENTRATA FOR UNEL SIDE SOCKET	PER UNEL CENTRATA FOR UNEL CENTRAL SOCKET
CONF. BOX 25 pz	CONF. BOX 25 pz	CONF. BOX 25 pz
IMBALLO PACKAGE 400 pz	IMBALLO PACKAGE 400 pz	IMBALLO PACKAGE 400 pz

FINITURE LEGNO WOODEN-LIKE FINISHES



LEGNO CHIARO LIGHT WOOD

ECL2591 LC ECL2592 LC ECL2593 LC

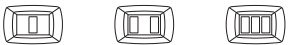

1 MODULO MODULE	2 MODULI MODULES	3 MODULI MODULES
CONF. BOX 25 pz	CONF. BOX 25 pz	CONF. BOX 25 pz
IMBALLO PACKAGE 400 pz	IMBALLO PACKAGE 400 pz	IMBALLO PACKAGE 400 pz



LEGNO SCURO DARK WOOD

ECL2591 LS ECL2592 LS ECL2593 LS



1 MODULO MODULE	2 MODULI MODULES	3 MODULI MODULES
CONF. BOX 25 pz	CONF. BOX 25 pz	CONF. BOX 25 pz
IMBALLO PACKAGE 400 pz	IMBALLO PACKAGE 400 pz	IMBALLO PACKAGE 400 pz



RADICA BURL WOOD

ECL2591 RA ECL2592 RA ECL2593 RA

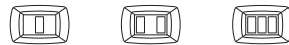

1 MODULO MODULE	2 MODULI MODULES	3 MODULI MODULES
CONF. BOX 25 pz	CONF. BOX 25 pz	CONF. BOX 25 pz
IMBALLO PACKAGE 400 pz	IMBALLO PACKAGE 400 pz	IMBALLO PACKAGE 400 pz



WENGÉ

ECL2591 WG ECL2592 WG ECL2593 WG



1 MODULO MODULE	2 MODULI MODULES	3 MODULI MODULES
CONF. BOX 25 pz	CONF. BOX 25 pz	CONF. BOX 25 pz
IMBALLO PACKAGE 400 pz	IMBALLO PACKAGE 400 pz	IMBALLO PACKAGE 400 pz

ECL2594 LC ECL2596 LC



4 MODULI MODULES	6 MODULI MODULES
CONF. BOX 15 pz	CONF. BOX 15 pz
IMBALLO PACKAGE 240 pz	IMBALLO PACKAGE 240 pz

ECL2594 LS ECL2596 LS



4 MODULI MODULES	6 MODULI MODULES
CONF. BOX 15 pz	CONF. BOX 15 pz
IMBALLO PACKAGE 240 pz	IMBALLO PACKAGE 240 pz

ECL2594 RA ECL2596 RA



4 MODULI MODULES	6 MODULI MODULES
CONF. BOX 15 pz	CONF. BOX 15 pz
IMBALLO PACKAGE 240 pz	IMBALLO PACKAGE 240 pz

ECL2594 WG ECL2596 WG



4 MODULI MODULES	6 MODULI MODULES
CONF. BOX 15 pz	CONF. BOX 15 pz
IMBALLO PACKAGE 240 pz	IMBALLO PACKAGE 240 pz

ECL2597 LC ECL2598 LC ECL2599 LC



2 MODULI RAVVICINATI NEARED	PER UNEL DECENTRATA FOR UNEL SIDE SOCKET	PER UNEL CENTRATA FOR UNEL CENTRAL SOCKET
CONF. BOX 25 pz	CONF. BOX 25 pz	CONF. BOX 25 pz
IMBALLO PACKAGE 400 pz	IMBALLO PACKAGE 400 pz	IMBALLO PACKAGE 400 pz

ECL2597 LS ECL2598 LS ECL2599 LS



2 MODULI RAVVICINATI NEARED	PER UNEL DECENTRATA FOR UNEL SIDE SOCKET	PER UNEL CENTRATA FOR UNEL CENTRAL SOCKET
CONF. BOX 25 pz	CONF. BOX 25 pz	CONF. BOX 25 pz
IMBALLO PACKAGE 400 pz	IMBALLO PACKAGE 400 pz	IMBALLO PACKAGE 400 pz

ECL2597 RA ECL2598 RA ECL2599 RA



2 MODULI RAVVICINATI NEARED	PER UNEL DECENTRATA FOR UNEL SIDE SOCKET	PER UNEL CENTRATA FOR UNEL CENTRAL SOCKET
CONF. BOX 25 pz	CONF. BOX 25 pz	CONF. BOX 25 pz
IMBALLO PACKAGE 400 pz	IMBALLO PACKAGE 400 pz	IMBALLO PACKAGE 400 pz

ECL2597 WG ECL2598 WG ECL2599 WG



2 MODULI RAVVICINATI NEARED	PER UNEL DECENTRATA FOR UNEL SIDE SOCKET	PER UNEL CENTRATA FOR UNEL CENTRAL SOCKET
CONF. BOX 25 pz	CONF. BOX 25 pz	CONF. BOX 25 pz
IMBALLO PACKAGE 400 pz	IMBALLO PACKAGE 400 pz	IMBALLO PACKAGE 400 pz

PLACCHE AUTOPORTANTI SELF SUPPORTING PLATES



ECLPR65 1F

Placca 1 modulo autoportante avorio per scatola tonda 65/85 mm

Cover fixing plate 1 module for round box 65/85 mm

CONF. BOX 25 pz
 IMBALLO PACKAGE 200 pz



ECLPR65 2F

Placca 2 moduli autoportante avorio per scatola tonda 65/85 mm

Cover fixing plate 2 modules for round box 65/85 mm

CONF. BOX 25 pz
 IMBALLO PACKAGE 200 pz



Vista posteriore
Back side view

Le placche autoportanti vengono fornite senza gli apparecchi modulari.
Self supporting plates are supplied without electrical devices.

VITI LUNGHE PER SUPPORTI LONG SCREWS FOR WALL FRAMES



ECLVT34AC

Viti lunghe mm 34 per supporti
Long screw for wall frames mm 34

CONF. BOX 100/1.000 pz
 IMBALLO PACKAGE 6.000 pz



ECLVT50AC

Viti lunghe mm 50 per supporti
Long screw for wall frames mm 50

CONF. BOX 100/500 pz
 IMBALLO PACKAGE 7.000 pz





VERSIONI DISPONIBILI AVAILABLE MODELS

Tondò Q



1 MODULO 1 MODULE



2 MODULI 2 MODULES



3 MODULI 3 MODULES



4 MODULI 4 MODULES



6 MODULI 6 MODULES



2 MODULI RAVVICINATI
2 MODULES NEARED



PER UNEL DECENTRATA
FOR UNEL SIDE SOCKET



PER UNEL CENTRATA
FOR UNEL CENTRAL SOCKET

FINITURE BASE BASIC FINISHES



BIANCO WHITE CE



AVORIO IVORY CE



NERO BLACK CE

ECL2691 WH ECL2692 WH ECL2693 WH

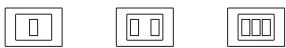

1 MODULO MODULE	2 MODULI MODULES	3 MODULI MODULES
CONFEZ. BOX 25 pz	CONFEZ. BOX 25 pz	CONFEZ. BOX 25 pz
IMBALLO PACKAGE 400 pz	IMBALLO PACKAGE 400 pz	IMBALLO PACKAGE 400 pz

ECL2691 A ECL2692 A ECL2693 A

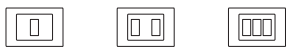

1 MODULO MODULE	2 MODULI MODULES	3 MODULI MODULES
CONFEZ. BOX 25 pz	CONFEZ. BOX 25 pz	CONFEZ. BOX 25 pz
IMBALLO PACKAGE 400 pz	IMBALLO PACKAGE 400 pz	IMBALLO PACKAGE 400 pz

ECL2691 N ECL2692 N ECL2693 N



1 MODULO MODULE	2 MODULI MODULES	3 MODULI MODULES
CONFEZ. BOX 25 pz	CONFEZ. BOX 25 pz	CONFEZ. BOX 25 pz
IMBALLO PACKAGE 400 pz	IMBALLO PACKAGE 400 pz	IMBALLO PACKAGE 400 pz

ECL2694 WH ECL2696 WH



4 MODULI MODULES	6 MODULI MODULES
CONFEZ. BOX 15 pz	CONFEZ. BOX 15 pz
IMBALLO PACKAGE 240 pz	IMBALLO PACKAGE 240 pz

ECL2694 A ECL2696 A



4 MODULI MODULES	6 MODULI MODULES
CONFEZ. BOX 15 pz	CONFEZ. BOX 15 pz
IMBALLO PACKAGE 240 pz	IMBALLO PACKAGE 240 pz

ECL2694 N ECL2696 N



4 MODULI MODULES	6 MODULI MODULES
CONFEZ. BOX 15 pz	CONFEZ. BOX 15 pz
IMBALLO PACKAGE 240 pz	IMBALLO PACKAGE 240 pz

ECL2697 WH ECL2698 WH ECL2699 WH

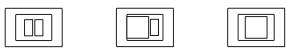

2 MODULI RAVVICINATI NEARED	PER UNEL DECENTRATA SIDE SOCKET	PER UNEL CENTRATA CENTRAL SOCKET
CONFEZ. BOX 25 pz	CONFEZ. BOX 25 pz	CONFEZ. BOX 25 pz
IMBALLO PACKAGE 400 pz	IMBALLO PACKAGE 400 pz	IMBALLO PACKAGE 400 pz

ECL2697 A ECL2698 A ECL2699 A

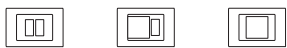

2 MODULI RAVVICINATI NEARED	PER UNEL DECENTRATA SIDE SOCKET	PER UNEL CENTRATA CENTRAL SOCKET
CONFEZ. BOX 25 pz	CONFEZ. BOX 25 pz	CONFEZ. BOX 25 pz
IMBALLO PACKAGE 400 pz	IMBALLO PACKAGE 400 pz	IMBALLO PACKAGE 400 pz

ECL2697 N ECL2698 N ECL2699 N

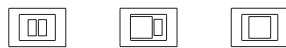

2 MODULI RAVVICINATI NEARED	PER UNEL DECENTRATA SIDE SOCKET	PER UNEL CENTRATA CENTRAL SOCKET
CONFEZ. BOX 25 pz	CONFEZ. BOX 25 pz	CONFEZ. BOX 25 pz
IMBALLO PACKAGE 400 pz	IMBALLO PACKAGE 400 pz	IMBALLO PACKAGE 400 pz

TONDÒ Q PLACCHE COPRINTERRUTTORI TONDÒ Q COVER PLATES

FINITURE PASTELLO PASTEL FINISHES

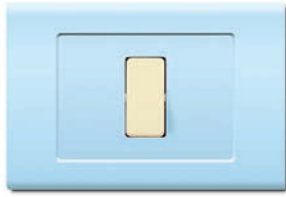

AZZURRO PASTELLO PASTEL AZURE

ECL2691 PA ECL2692 PA ECL2693 PA



1 MODULO MODULE	2 MODULI MODULES	3 MODULI MODULES
CONF. BOX 25 pz	CONF. BOX 25 pz	CONF. BOX 25 pz
IMBALLO PACKAGE 400 pz	IMBALLO PACKAGE 400 pz	IMBALLO PACKAGE 400 pz

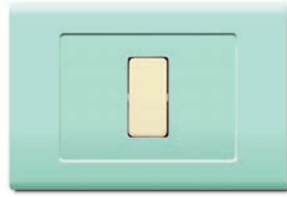

VERDE PASTELLO PASTEL GREEN

ECL2691 PG ECL2692 PG ECL2693 PG



1 MODULO MODULE	2 MODULI MODULES	3 MODULI MODULES
CONF. BOX 25 pz	CONF. BOX 25 pz	CONF. BOX 25 pz
IMBALLO PACKAGE 400 pz	IMBALLO PACKAGE 400 pz	IMBALLO PACKAGE 400 pz



GIALLO PASTELLO PASTEL YELLOW

ECL2691 PY ECL2692 PY ECL2693 PY



1 MODULO MODULE	2 MODULI MODULES	3 MODULI MODULES
CONF. BOX 25 pz	CONF. BOX 25 pz	CONF. BOX 25 pz
IMBALLO PACKAGE 400 pz	IMBALLO PACKAGE 400 pz	IMBALLO PACKAGE 400 pz



ARANCIO PASTELLO PASTEL ORANGE

ECL2691 PO ECL2692 PO ECL2693 PO



1 MODULO MODULE	2 MODULI MODULES	3 MODULI MODULES
CONF. BOX 25 pz	CONF. BOX 25 pz	CONF. BOX 25 pz
IMBALLO PACKAGE 400 pz	IMBALLO PACKAGE 400 pz	IMBALLO PACKAGE 400 pz

ECL2694 PA ECL2696 PA



4 MODULI MODULES	6 MODULI MODULES
CONF. BOX 15 pz	CONF. BOX 15 pz
IMBALLO PACKAGE 240 pz	IMBALLO PACKAGE 240 pz

ECL2694 PG ECL2696 PG



4 MODULI MODULES	6 MODULI MODULES
CONF. BOX 15 pz	CONF. BOX 15 pz
IMBALLO PACKAGE 240 pz	IMBALLO PACKAGE 240 pz

ECL2694 PY ECL2696 PY



4 MODULI MODULES	6 MODULI MODULES
CONF. BOX 15 pz	CONF. BOX 15 pz
IMBALLO PACKAGE 240 pz	IMBALLO PACKAGE 240 pz

ECL2694 PO ECL2696 PO



4 MODULI MODULES	6 MODULI MODULES
CONF. BOX 15 pz	CONF. BOX 15 pz
IMBALLO PACKAGE 240 pz	IMBALLO PACKAGE 240 pz

ECL2697 PA ECL2698 PA ECL2699 PA

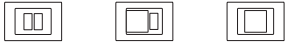

2 MODULI RAVVICINATI 2 MODULES NEARED	PER UNEL DECENTRATA FOR UNEL SIDE SOCKET	PER UNEL CENTRATA FOR UNEL CENTRAL SOCKET
CONF. BOX 25 pz	CONF. BOX 25 pz	CONF. BOX 25 pz
IMBALLO PACKAGE 400 pz	IMBALLO PACKAGE 400 pz	IMBALLO PACKAGE 400 pz

ECL2697 PG ECL2698 PG ECL2699 PG

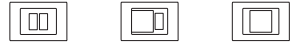

2 MODULI RAVVICINATI 2 MODULES NEARED	PER UNEL DECENTRATA FOR UNEL SIDE SOCKET	PER UNEL CENTRATA FOR UNEL CENTRAL SOCKET
CONF. BOX 25 pz	CONF. BOX 25 pz	CONF. BOX 25 pz
IMBALLO PACKAGE 400 pz	IMBALLO PACKAGE 400 pz	IMBALLO PACKAGE 400 pz

ECL2697 PY ECL2698 PY ECL2699 PY

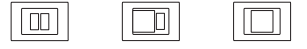

2 MODULI RAVVICINATI 2 MODULES NEARED	PER UNEL DECENTRATA FOR UNEL SIDE SOCKET	PER UNEL CENTRATA FOR UNEL CENTRAL SOCKET
CONF. BOX 25 pz	CONF. BOX 25 pz	CONF. BOX 25 pz
IMBALLO PACKAGE 400 pz	IMBALLO PACKAGE 400 pz	IMBALLO PACKAGE 400 pz

ECL2697 PO ECL2698 PO ECL2699 PO

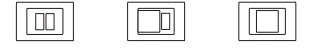

2 MODULI RAVVICINATI 2 MODULES NEARED	PER UNEL DECENTRATA FOR UNEL SIDE SOCKET	PER UNEL CENTRATA FOR UNEL CENTRAL SOCKET
CONF. BOX 25 pz	CONF. BOX 25 pz	CONF. BOX 25 pz
IMBALLO PACKAGE 400 pz	IMBALLO PACKAGE 400 pz	IMBALLO PACKAGE 400 pz

FINITURE METALLICHE METALLIC FINISHES



ORO GOLD

ECL2691 OR ECL2692 OR ECL2693 OR

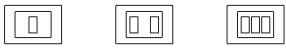

1 MODULO MODULE	2 MODULI MODULES	3 MODULI MODULES
CONF. BOX 25 pz	CONF. BOX 25 pz	CONF. BOX 25 pz
IMBALLO PACKAGE 400 pz	IMBALLO PACKAGE 400 pz	IMBALLO PACKAGE 400 pz



ALLUMINIO NOTTE DARK ALUMINIUM

ECL2691 AN ECL2692 AN ECL2693 AN

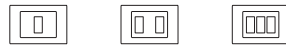

1 MODULO MODULE	2 MODULI MODULES	3 MODULI MODULES
CONF. BOX 25 pz	CONF. BOX 25 pz	CONF. BOX 25 pz
IMBALLO PACKAGE 400 pz	IMBALLO PACKAGE 400 pz	IMBALLO PACKAGE 400 pz

ECL2694 OR ECL2696 OR



4 MODULI MODULES	6 MODULI MODULES
CONF. BOX 15 pz	CONF. BOX 15 pz
IMBALLO PACKAGE 240 pz	IMBALLO PACKAGE 240 pz

ECL2694 AN ECL2696 AN



4 MODULI MODULES	6 MODULI MODULES
CONF. BOX 15 pz	CONF. BOX 15 pz
IMBALLO PACKAGE 240 pz	IMBALLO PACKAGE 240 pz

ECL2697 OR ECL2698 OR ECL2699 OR



2 MODULI RAVVICINATI 2 MODULES NEARED	PER UNEL DECENTRATA FOR UNEL SIDE SOCKET	PER UNEL CENTRATA FOR UNEL CENTRAL SOCKET
CONF. BOX 25 pz	CONF. BOX 25 pz	CONF. BOX 25 pz
IMBALLO PACKAGE 400 pz	IMBALLO PACKAGE 400 pz	IMBALLO PACKAGE 400 pz

ECL2697 AN ECL2698 AN ECL2699 AN

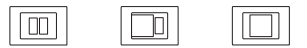

2 MODULI RAVVICINATI 2 MODULES NEARED	PER UNEL DECENTRATA FOR UNEL SIDE SOCKET	PER UNEL CENTRATA FOR UNEL CENTRAL SOCKET
CONF. BOX 25 pz	CONF. BOX 25 pz	CONF. BOX 25 pz
IMBALLO PACKAGE 400 pz	IMBALLO PACKAGE 400 pz	IMBALLO PACKAGE 400 pz

FINITURE VULCANIZZATE VULCANISED FINISHES



GRIGIO NOTTE DARK GREY **CE**

ECL2691 V-GN ECL2692 V-GN ECL2693 V-GN

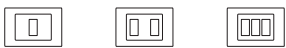

1 MODULO MODULE	2 MODULI MODULES	3 MODULI MODULES
CONF. BOX 25 pz	CONF. BOX 25 pz	CONF. BOX 25 pz
IMBALLO PACKAGE 400 pz	IMBALLO PACKAGE 400 pz	IMBALLO PACKAGE 400 pz



GRIGIO CHIARO LIGHT GREY **CE**

ECL2691 V-GC ECL2692 V-GC ECL2693 V-GC

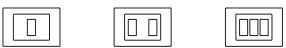

1 MODULO MODULE	2 MODULI MODULES	3 MODULI MODULES
CONF. BOX 25 pz	CONF. BOX 25 pz	CONF. BOX 25 pz
IMBALLO PACKAGE 400 pz	IMBALLO PACKAGE 400 pz	IMBALLO PACKAGE 400 pz

ECL2694 V-GN ECL2696 V-GN



4 MODULI MODULES	6 MODULI MODULES
CONF. BOX 15 pz	CONF. BOX 15 pz
IMBALLO PACKAGE 240 pz	IMBALLO PACKAGE 240 pz

ECL2694 V-GC ECL2696 V-GC



4 MODULI MODULES	6 MODULI MODULES
CONF. BOX 15 pz	CONF. BOX 15 pz
IMBALLO PACKAGE 240 pz	IMBALLO PACKAGE 240 pz

ECL2697 V-GN ECL2698 V-GN ECL2699 V-GN

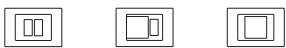

2 MODULI RAVVICINATI 2 MODULES NEARED	PER UNEL DECENTRATA FOR UNEL SIDE SOCKET	PER UNEL CENTRATA FOR UNEL CENTRAL SOCKET
CONF. BOX 25 pz	CONF. BOX 25 pz	CONF. BOX 25 pz
IMBALLO PACKAGE 400 pz	IMBALLO PACKAGE 400 pz	IMBALLO PACKAGE 400 pz

ECL2697 V-GC ECL2698 V-GC ECL2699 V-GC

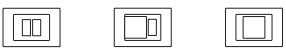

2 MODULI RAVVICINATI 2 MODULES NEARED	PER UNEL DECENTRATA FOR UNEL SIDE SOCKET	PER UNEL CENTRATA FOR UNEL CENTRAL SOCKET
CONF. BOX 25 pz	CONF. BOX 25 pz	CONF. BOX 25 pz
IMBALLO PACKAGE 400 pz	IMBALLO PACKAGE 400 pz	IMBALLO PACKAGE 400 pz

FINITURE LEGNO WOODEN-LIKE FINISHES



LEGNO CHIARO LIGHT WOOD **CE**

ECL2691 LC ECL2692 LC ECL2693 LC



1 MODULO MODULE	2 MODULI MODULES	3 MODULI MODULES
CONF. BOX 25 pz	CONF. BOX 25 pz	CONF. BOX 25 pz
IMBALLO PACKAGE 400 pz	IMBALLO PACKAGE 400 pz	IMBALLO PACKAGE 400 pz



LEGNO SCURO DARK WOOD **CE**

ECL2691 LS ECL2692 LS ECL2693 LS



1 MODULO MODULE	2 MODULI MODULES	3 MODULI MODULES
CONF. BOX 25 pz	CONF. BOX 25 pz	CONF. BOX 25 pz
IMBALLO PACKAGE 400 pz	IMBALLO PACKAGE 400 pz	IMBALLO PACKAGE 400 pz



RADICA BURL WOOD **CE**

ECL2691 RA ECL2692 RA ECL2693 RA



1 MODULO MODULE	2 MODULI MODULES	3 MODULI MODULES
CONF. BOX 25 pz	CONF. BOX 25 pz	CONF. BOX 25 pz
IMBALLO PACKAGE 400 pz	IMBALLO PACKAGE 400 pz	IMBALLO PACKAGE 400 pz



WENGÉ **CE**

ECL2691 WG ECL2692 WG ECL2693 WG

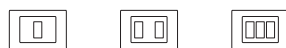

1 MODULO MODULE	2 MODULI MODULES	3 MODULI MODULES
CONF. BOX 25 pz	CONF. BOX 25 pz	CONF. BOX 25 pz
IMBALLO PACKAGE 400 pz	IMBALLO PACKAGE 400 pz	IMBALLO PACKAGE 400 pz

ECL2694 LC ECL2696 LC



4 MODULI MODULES	6 MODULI MODULES
CONF. BOX 15 pz	CONF. BOX 15 pz
IMBALLO PACKAGE 240 pz	IMBALLO PACKAGE 240 pz

ECL2694 LS ECL2696 LS



4 MODULI MODULES	6 MODULI MODULES
CONF. BOX 15 pz	CONF. BOX 15 pz
IMBALLO PACKAGE 240 pz	IMBALLO PACKAGE 240 pz

ECL2694 RA ECL2696 RA



4 MODULI MODULES	6 MODULI MODULES
CONF. BOX 15 pz	CONF. BOX 15 pz
IMBALLO PACKAGE 240 pz	IMBALLO PACKAGE 240 pz

ECL2694 WG ECL2696 WG



4 MODULI MODULES	6 MODULI MODULES
CONF. BOX 15 pz	CONF. BOX 15 pz
IMBALLO PACKAGE 240 pz	IMBALLO PACKAGE 240 pz

ECL2697 LC ECL2698 LC ECL2699 LC



2 MODULI RAVVICINATI 2 MODULES NEARED	PER UNEL DECENTRATA FOR UNEL SIDE SOCKET	PER UNEL CENTRATA FOR UNEL CENTRAL SOCKET
CONF. BOX 25 pz	CONF. BOX 25 pz	CONF. BOX 25 pz
IMBALLO PACKAGE 400 pz	IMBALLO PACKAGE 400 pz	IMBALLO PACKAGE 400 pz

ECL2697 LS ECL2698 LS ECL2699 LS

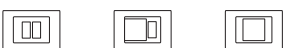

2 MODULI RAVVICINATI 2 MODULES NEARED	PER UNEL DECENTRATA FOR UNEL SIDE SOCKET	PER UNEL CENTRATA FOR UNEL CENTRAL SOCKET
CONF. BOX 25 pz	CONF. BOX 25 pz	CONF. BOX 25 pz
IMBALLO PACKAGE 400 pz	IMBALLO PACKAGE 400 pz	IMBALLO PACKAGE 400 pz

ECL2697 RA ECL2698 RA ECL2699 RA



2 MODULI RAVVICINATI 2 MODULES NEARED	PER UNEL DECENTRATA FOR UNEL SIDE SOCKET	PER UNEL CENTRATA FOR UNEL CENTRAL SOCKET
CONF. BOX 25 pz	CONF. BOX 25 pz	CONF. BOX 25 pz
IMBALLO PACKAGE 400 pz	IMBALLO PACKAGE 400 pz	IMBALLO PACKAGE 400 pz

ECL2697 WG ECL2698 WG ECL2699 WG



2 MODULI RAVVICINATI 2 MODULES NEARED	PER UNEL DECENTRATA FOR UNEL SIDE SOCKET	PER UNEL CENTRATA FOR UNEL CENTRAL SOCKET
CONF. BOX 25 pz	CONF. BOX 25 pz	CONF. BOX 25 pz
IMBALLO PACKAGE 400 pz	IMBALLO PACKAGE 400 pz	IMBALLO PACKAGE 400 pz

CONTENITORI DA PARETE WALL MOUNTING BOXES



EC300A1

Contenitore da parete
per 1 apparecchio tipo TONDÒ®
*Wall box
for 1 TONDÒ® electrical device*

CONFEZ.
BOX 1 pz
IMBALLO
PACKAGE 60 pz

CE
IP40
Grigio/Grey RAL 7035
Dimensioni/Size: 67x83x51 mm



EC300A2

Contenitore da parete
per 2 apparecchi tipo TONDÒ®
*Wall box
for 2 TONDÒ® electrical devices*

CONFEZ.
BOX 1 pz
IMBALLO
PACKAGE 60 pz

CE
IP40
Grigio/Grey RAL 7035
Dimensioni/Size: 67x83x51 mm



EC300A3

Contenitore da parete
per 3 apparecchi tipo TONDÒ®
*Wall box
for 3 TONDÒ® electrical devices*

CONFEZ.
BOX 1 pz
IMBALLO
PACKAGE 40 pz

CE
IP40
Grigio/Grey RAL 7035
Dimensioni/Size: 100x83x51 mm



EC300A4

Contenitore da parete
per 4 apparecchi tipo TONDÒ®
*Wall box
for 4 TONDÒ® electrical devices*

CONFEZ.
BOX 1 pz
IMBALLO
PACKAGE 30 pz

CE
IP40
Grigio/Grey RAL 7035
Dimensioni/Size: 122x83x51 mm



EC300A6

Contenitore da parete
per 6 apparecchi tipo TONDÒ®
*Wall box
for 6 TONDÒ® electrical devices*

CONFEZ.
BOX 1 pz
IMBALLO
PACKAGE 20 pz

CE
IP40
Grigio/Grey RAL 7035
Dimensioni/Size: 177x83x51 mm



EC300A4V

Contenitore da parete
per 4 apparecchi verticali tipo TONDÒ®
Wall box for 4 TONDÒ® vertical electrical devices

CONFEZ.
BOX 1 pz
IMBALLO
PACKAGE 25 pz

CE
IP40
Grigio/Grey RAL 7035
Dimensioni/Size: 67x180x51 mm



EC300A6V

Contenitore da parete
per 6 apparecchi verticali tipo TONDÒ®
Wall box for 6 TONDÒ® vertical electrical devices

CONFEZ.
BOX 1 pz
IMBALLO
PACKAGE 18 pz

CE
IP40
Grigio/Grey RAL 7035
Dimensioni/Size: 100x180x51 mm

CONTENITORI DA PARETE CON PORTELLO WALL MOUNTING BOXES WITH HATCH



EC310A1

Contenitore da parete con portello per 1 apparecchio tipo TONDÒ®

Wall box with hatch for 1 TONDÒ® electrical device

CONFEZ. BOX 1 pz
IMBALLO PACKAGE 50 pz

CE
IP55
Grigio/Grey RAL 7035
Dimensioni/Size: 67x83x59 mm



EC310A2

Contenitore da parete con portello per 2 apparecchi tipo TONDÒ®

Wall box with hatch for 2 TONDÒ® electrical devices

CONFEZ. BOX 1 pz
IMBALLO PACKAGE 50 pz

CE
IP55
Grigio/Grey RAL 7035
Dimensioni/Size: 67x83x59 mm



EC310A3

Contenitore da parete con portello per 3 apparecchi tipo TONDÒ®

Wall box with hatch for 3 TONDÒ® electrical devices

CONFEZ. BOX 1 pz
IMBALLO PACKAGE 35 pz

CE
IP55
Grigio/Grey RAL 7035
Dimensioni/Size: 100x83x59 mm



EC310A4

Contenitore da parete con portello per 4 apparecchi tipo TONDÒ®

Wall box with hatch for 4 TONDÒ® electrical devices

CONFEZ. BOX 1 pz
IMBALLO PACKAGE 25 pz

CE
IP55
Grigio/Grey RAL 7035
Dimensioni/Size: 122x83x59 mm



EC310A4V

Contenitore da parete con portello per 4 apparecchi verticali tipo TONDÒ®

Wall box with hatch for 4 TONDÒ® vertical electrical devices

CONFEZ. BOX 1 pz
IMBALLO PACKAGE 20 pz

CE
IP55
Grigio/Grey RAL 7035
Dimensioni/Size: 67x180x59 mm



EC310A6V

Contenitore da parete con portello per 6 apparecchi verticali tipo TONDÒ®

Wall box with hatch for 6 TONDÒ® vertical electrical devices

CONFEZ. BOX 1 pz
IMBALLO PACKAGE 15 pz

CE
IP55
Grigio/Grey RAL 7035
Dimensioni/Size: 100x180x59 mm

PLACCHE AUTOPORTANTI CON PORTELLO GW SYSTEM, MAGIC E SIMILARI SELF-SUPPORTING PLATE WITH HATCH GW SYSTEM, MAGIC AND SIMILAR



EC316B

Placca autoportante con portello per 3 apparecchi tipo TONDÒ®
Self-supporting plate with hatch for 3 TONDÒ® electrical devices



CONFEZ. BOX 1 pz
IMBALLO PACKAGE 40 pz

IP55
Bianco/White RAL 9001
Dimensioni/Size: 130x85x26 mm



EC316G

Placca autoportante con portello per 3 apparecchi tipo TONDÒ®
Self-supporting plate with hatch for 3 TONDÒ® electrical devices



CONFEZ. BOX 1 pz
IMBALLO PACKAGE 40 pz

IP55
Grigio/Grey RAL 7035
Dimensioni/Size: 130x85x26 mm



EC316N

Placca autoportante con portello per 3 apparecchi tipo TONDÒ®
Self-supporting plate with hatch for 3 TONDÒ® electrical devices



CONFEZ. BOX 1 pz
IMBALLO PACKAGE 40 pz

IP55
Antracite RAL 7021
Dimensioni/Size: 130x85x26 mm



NOVITÀ NEW

EC3164B

Placca autoportante con portello per 4 apparecchi tipo TONDÒ®
Self-supporting plate with hatch for 4 TONDÒ® electrical devices



CONFEZ. BOX 1 pz
IMBALLO PACKAGE 120 pz

IP55
Bianco/White RAL 9001
Dimensioni/Size: 154x85x26 mm



NOVITÀ NEW

EC3164G

Placca autoportante con portello per 4 apparecchi tipo TONDÒ®
Self-supporting plate with hatch for 4 TONDÒ® electrical devices



CONFEZ. BOX 1 pz
IMBALLO PACKAGE 120 pz

IP55
Grigio/Grey RAL 7035
Dimensioni/Size: 154x85x26 mm



NOVITÀ NEW

EC3164N

Placca autoportante con portello per 4 apparecchi tipo TONDÒ®
Self-supporting plate with hatch for 4 TONDÒ® electrical devices



CONFEZ. BOX 1 pz
IMBALLO PACKAGE 120 pz

IP55
Antracite RAL 7021
Dimensioni/Size: 154x85x26 mm

PLACCHE AUTOPORTANTI CON PORTELLO MAGIC E SIMILARI SELF-SUPPORTING PLATE WITH HATCH MAGIC AND SIMILAR



EC315B

Placca autoportante con portello per 3 apparecchi tipo TONDÒ®
Self-supporting plate with hatch for 3 TONDÒ® electrical devices



CONFEZ.
BOX 1 pz
IMBALLO
PACKAGE 40 pz

IP55
Bianco/White RAL 9001
Dimensioni/Size: 125x90x20 mm



EC315G

Placca autoportante con portello per 3 apparecchi tipo TONDÒ®
Self-supporting plate with hatch for 3 TONDÒ® electrical devices



CONFEZ.
BOX 1 pz
IMBALLO
PACKAGE 40 pz

IP55
Grigio/Grey RAL 7035
Dimensioni/Size: 125x90x20 mm



EC315A

Placca autoportante con portello per 3 apparecchi tipo TONDÒ®
Self-supporting plate with hatch for 3 TONDÒ® electrical devices



CONFEZ.
BOX 1 pz
IMBALLO
PACKAGE 40 pz

IP55
Avorio/Ivory
Dimensioni/Size: 125x90x20 mm

SCATOLE PER APPARECCHI TONDÒ® ADAPTOR BOXES FOR TONDÒ® DEVICES



ECSM0

Scatola cieca
Blank adaptor box



IMBALLO
PACKAGE 30 pz

IP40
Bianco/White RAL 9001
Dimensioni/Size: 52x64x46 mm



ECSM1

Scatola per 1 apparecchio tipo TONDÒ®
Adaptor box for 1 TONDÒ® electrical device



IMBALLO
PACKAGE 30 pz

IP40
Bianco/White RAL 9001
Dimensioni/Size: 52x64x46 mm



ECSM2

Scatola per 2 apparecchi tipo TONDÒ®
Adaptor box for 2 TONDÒ® electrical devices



IMBALLO
PACKAGE 30 pz

IP40
Bianco/White RAL 9001
Dimensioni/Size: 52x64x46 mm



I trasformatori ELETTRICANALI, adatti all'alimentazione monofase fino a 63VA, garantiscono una totale separazione tra i circuiti Primario e Secondario con isolamento rinforzato.

Possano essere installati sia in barra DIN che a parete.

Sono realizzati con contenitore in policarbonato autoestinguente provvisto di ganci e calotte coprimorsetto di protezione per il montaggio diretto a parete.

Il loro utilizzo può essere sia per servizio intermittente che continuativo, ma con riduzione della potenza massima del 30%.

CARATTERISTICHE GENERALI

Grado di protezione: IP20

IP30 (con calotte)

IP40 (a retroquadro)

Classe di Isolamento: II 

Colore: Grigio RAL 7035

ESEMPI DI UTILIZZO:

- Elettroserrature
- Campanelli
- Utenze con bassa tensione
- Quadristica residenziale-industriale in genere

NOTA: Per l'alimentazione di carichi fortemente induttivi la riduzione di potenza deve essere pari al cosfi del carico applicato.

ESEMPIO: Alimentazione elettrovalvola con cosfi pari a 0,6; Trasformatore di alimentazione di 30VA; La potenza nominale del trasformatore viene ridotta di: $30 \times 0,6 = 18$; $30 - 18 = 12VA$.

ELETTROCANALI transformers, fit to single phase power supply up to 63VA, assure a total separation between primary and secondary systems with reinforced isolation.

They could be installed for DIN bar or for wall mount.

They are produced with box in self-extinguishing polycarbonate, that has protection fasteners and cover contact for direct installation on wall mount.

They could be used for intermittent operation and also for continuous one but with 30% decrease in power supply.

MAIN FEATURES

Protection degree: IP20

IP30 (with caps)

IP40 (in modular enclosures)

Isolation class: II 

Colour: Grey RAL 7035

APPLICATION EXAMPLES:

- Electro locks
- Bells
- Low voltage uses
- Civil-industrial distribution board

NOTE: To supply highly inductive loads, power reduction must be equal to the power factor of the load applied.

EXAMPLE: Solenoid valve power supply with power factor of 0.6; Power transformer of 30VA; The power rating of transformer is reduced by: $30 \times 0.6 = 18$; $30 - 18 = 12VA$.



ECL4315

Trasformatore DIN e parete - 2 moduli
Transformer for DIN bar or wall mount - 2 modules

CONFEZ. BOX 1 pz
IMBALLO PACKAGE 40 pz



CARATTERISTICHE

Potenza nominale intermittente 15VA
Potenza nominale continua 10VA
Tensione di alimentazione (primario) 220V~ 50Hz
Tensione di uscita (secondario) 4.8.12V~

FEATURES

Intermittent power 15VA
Continuous power 10VA
Supply voltage (primary) 220V~ 50Hz
Exit voltage (secondary) 4.8.12V~



ECL4330

Trasformatore DIN e parete - 3 moduli
Transformer for DIN bar or wall mount - 3 modules

CONFEZ. BOX 1 pz
IMBALLO PACKAGE 24 pz



CARATTERISTICHE

Potenza nominale intermittente 30VA
Potenza nominale continua 21VA
Tensione di alimentazione (primario) 220V~ 50Hz
Tensione di uscita (secondario) 12.12.24V~

FEATURES

Intermittent power 30VA
Continuous power 21VA
Supply voltage (primary) 220V~ 50Hz
Exit voltage (secondary) 12.12.24V~



ECL4340

Trasformatore DIN e parete - 3 moduli
Transformer for DIN bar or wall mount - 3 modules

CONFEZ. BOX 1 pz
IMBALLO PACKAGE 24 pz



CARATTERISTICHE

Potenza nominale intermittente 40VA
Potenza nominale continua 28VA
Tensione di alimentazione (primario) 220V~ 50Hz
Tensione di uscita (secondario) 12.12.24V~

FEATURES

Intermittent power 40VA
Continuous power 28VA
Supply voltage (primary) 220V~ 50Hz
Exit voltage (secondary) 12.12.24V~



ECL4350

Trasformatore DIN e parete - 4 moduli
Transformer for DIN bar or wall mount - 4 modules

CONFEZ. BOX	1 pz
IMBALLO PACKAGE	20 pz



CARATTERISTICHE

Potenza nominale intermittente 50VA
Potenza nominale continua 35VA
Tensione di alimentazione (primario) 220V~ 50Hz
Tensione di uscita (secondario) 12.12.24V~

FEATURES

Intermittent power 50VA
Continuous power 35VA
Supply voltage (primary) 220V~ 50Hz
Exit voltage (secondary) 12.12.24V~



ECL4363

Trasformatore DIN e parete - 4 moduli
Transformer for DIN bar or wall mount - 4 modules

CONFEZ. BOX	1 pz
IMBALLO PACKAGE	20 pz



CARATTERISTICHE

Potenza nominale intermittente 63VA
Potenza nominale continua 44VA
Tensione di alimentazione (primario) 220V~ 50Hz
Tensione di uscita (secondario) 12.12.24V~

FEATURES

Intermittent power 63VA
Continuous power 44VA
Supply voltage (primary) 220V~ 50Hz
Exit voltage (secondary) 12.12.24V~

APPARECCHI AUSILIARI ADDITIONAL DEVICES



ECL4301

Temporizzatore elettronico luci scala - 1 modulo
Electronic stairs light dimer - 1 module

IMBALLO PACKAGE	1 pz
-----------------	------

230V~ 50/60Hz



Il timer elettronico per comando luci scala si attiva tramite un contatto normalmente aperto con disinserzione ritardata. È caratterizzato da un sistema di temporizzazione elettronica ad alta sensibilità con regolazione continua, tramite trimmer (da 30 sec a 10 min). Ha un tipo di collegamento a 3 fili con pulsanti riferiti alla fase ed un funzionamento con pulsanti luminosi fino ad un assorbimento massimo di 50 mA (circa 30 pulsanti). È possibile ottenere una temporizzazione ed una illuminazione permanente. È realizzato con contenitore standard modulare componibile, ingombro 1 modulo DIN, con possibilità di aggancio sia su guida DIN che a parete tramite particolari asole di fissaggio e cuffie di protezione cavi. Viene generalmente utilizzato per l'illuminazione temporizzata in scale, corridoi, cantine, box, ingressi.

CARATTERISTICHE TECNICHE

Alimentazione: 230V~ ± 15%
Frequenza: 50/60Hz
Campo regolazione: 30 sec ÷ 10 min (toll. 20%)
Carico lamp. incand.: 1.600W
Carico lamp. fluoresc.: 750W
Pulsanti luminosi: max 30
Contatto uscita: N/O - 10A - $\cos\phi = 1$ - 250V~
Temperatura di esercizio: -20°C ÷ +50°C
Norme di riferimento: EMC: 89/336 CEE, 92/31 CEE, 93/68 CEE
B.T.: 73/23 CEE, 93/68 CEE

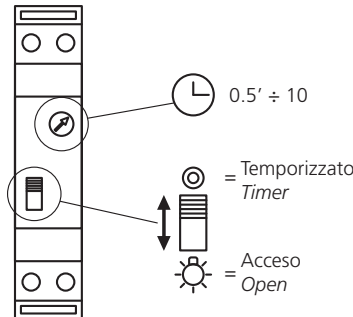

Electronic timer to drive stairs lights sets up through a normally open contact with adjustable delayed switch off.

It's characterized by a high sensitivity electric timer system with continuous adjustment by a trimmer (range 3 sec. - 10 min.).

It has a 3 wires connection system with lighted push-buttons up to maximum absorption of 50mA (about 30 push-buttons).

It's possible to obtain a timed or permanent lighting.

It's produced with a standard DIN box 1 module wide, with both DIN bar clamp system and wall mount through fixing holes and covers for wires protection. It's generally used for timer lighting of stairs, corridors, cellars, box and entrances.

TECHNICAL SPECIFICATIONS

Power supply: 230V~ ± 15%
Frequency: 50/60Hz
Time range: 30 sec ÷ 10 min (toll. 20%)
Incandescent lamps load: 1.600W
Fluorescent lamps load: 750W
Lighted push-buttons: max 30
Output switch: N/O - 10A - $\cos\phi = 1$ - 250V~
Operating temperature: -20°C ÷ +50°C
Rules compliances: EMC: 89/336 CEE, 92/31 CEE, 93/68 CEE
B.T.: 73/23 CEE, 93/68 CEE

APPARECCHI AUSILIARI ADDITIONAL DEVICES



ECL4302

Limitatore di sovratensione su barra DIN - 2 moduli
DIN bar over tension limiter - 2 modules

CONFEZ. BOX 1 pz
IMBALLO PACKAGE 40 pz

CE
230V~ 50Hz

Le sovratensioni sono picchi di tensione di breve durata (detti transitori) che si instaurano per frazioni di secondo, raggiungendo valori di tensione di diverse migliaia di Volt. Possono essere generate da fulminazione indiretta, manovre di commutazione in rete e da grosse energie impulsive.

Il limitatore, installato a monte dell'interruttore differenziale, protegge quest'ultimo da scatti intempestivi causati da scariche atmosferiche o da sovratensioni di altro tipo. È idoneo per impianti monofase di tipo TN, per la protezione di apparecchiature in ambito domestico.

La funzione di protezione attiva viene visualizzata da un led verde, lo spegnimento di questo led e l'accensione di un altro led rosso indica che la protezione non è più attiva e quindi il limitatore va sostituito.

Questo dispositivo opera in maniera sicura e ottimale solo in presenza di un efficace impianto di terra (legge 46/90).

Spikes are short voltage peaks that could be reach voltage values of thousands of Volt, and could be generated by direct and indirect lightning, switching operations, impulsive energy.

The tension limiter, installed upstream of main differential switch, protects it from shocks caused by lightning or other overvoltage. It could be used in TN monophasic systems, for protection of domestic devices.

Protection function is active when green led is ON. If this led is OFF or it becomes red, protection function is not active and it is time to replace the device now ineffective.

Device works safe and efficient only in the presence of an effective earth system (law 46/90).

CARATTERISTICHE TECNICHE

Tensione nominale: 230V~ 50Hz
Corrente di linea: 16A
Corrente nominale di scarica: 5 kA
Corrente max di scarica: 20 kA
Massima tensione di picco: 1 kV
Forma d'onda: 8/20 μ s
Tempo di intervento: <25 ns
Temperatura di esercizio: -20°C ÷ +60°C

TECHNICAL SPECIFICATIONS

Nominal tension: 230V~ 50Hz
Nominal load: 16A
Discharge nominal load: 5 kA
Max discharge load: 20 kA
Max spike load: 1 kV
Wave form: 8/20 μ s
Switching time: <25 ns
Operating temperature: -20°C ÷ +60°C

DIAGRAMMA DI FUNZIONAMENTO

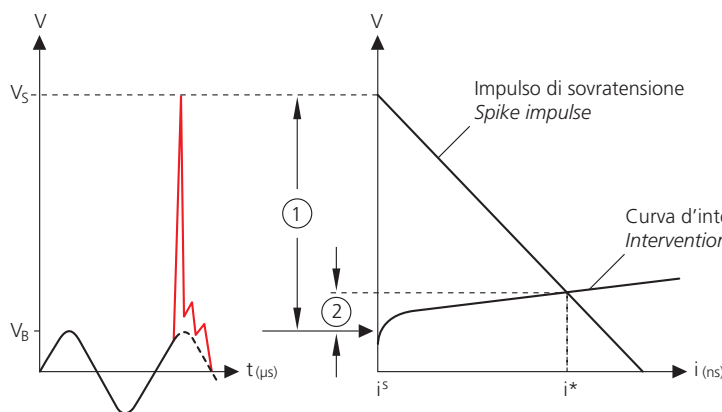

FUNCTION DIAGRAM



COMMUTATORE 1P 2 WAY 1P SWITCH

ECL4020 TEC pag. 10, ECL4020 WH pag. 20, ECL4020 pag. 30.

Può essere impiegato con lo stesso scopo dei doppi pulsanti (ECL4022-ECL4023). A differenza di questi ultimi, il commutatore mantiene sempre l'ultima posizione premuta ON, fino a quando manualmente non lo si riporta in posizione centrale OFF. Se l'operatore, dopo aver premuto il commutatore, si allontana, il dispositivo, ad esso collegato, continua a funzionare, per cui, nel caso si trattasse di una persiana motorizzata, sarebbe indispensabile controllare l'efficienza dei fine corsa.

ECL4020 TEC page 10, ECL4020 WH page 20, ECL4020 page 30.

It could be used with the same purpose of twin single pole push buttons (ECL4022-ECL4023). Differently from these, 2 way 1P switch ever holds last pressed position until manually is carried on the central position. If an operator, after pressing this switch, goes away, the device, connected with ECL4020, will continue to work. If the device is a roller shutter, it would be necessary to check full stroke efficiency.

DOPPIO PULSANTE INTERBLOCCATO INTERLOCKED TWIN SINGLE POLE PUSH BUTTON

ECL4022 TEC pag. 10, ECL4022 WH pag. 20, ECL4022 pag. 30, ECL4022 WHAB pag. 41, ECSE8037 pag. 86.

È dotato di interblocco meccanico, che permette di premere un tasto alla volta in modo tale da garantire l'integrità elettrica del motore a cui è abbinato. È utilizzato tipicamente come comando di tapparelle motorizzate. Esempi esplicativi sono presenti nella sezione "Sistemi per impianti dedicati" a pag. 58 e 59.

ECL4022 TEC page 10, ECL4022 WH page 20, ECL4022 page 30, ECL4022 WHAB page 41, ECSE8037 page 86.

It's provided with mechanical interlock, that enables to push one device at a time, to preserve the electric integrity of engine which is linked together. It's typically used as blinds control. Explicative examples are in the section "Systems for dedicated equipment" pages 58 and 59.

DOPPIO PULSANTE TWIN SINGLE POLE PUSH BUTTON

ECL4023 TEC pag. 10, ECL4023 WH pag. 20, ECL4023 pag. 30, ECSE8035 pag. 86.

È costituito da 2 pulsanti separati sia elettricamente che meccanicamente per cui racchiude in un solo modulo le funzioni di due pulsanti distinti. Viene utilizzato in circuiti di segnalazione o applicazioni similari.

ECL4023 TEC page 10, ECL4023 WH page 20, ECL4023 page 30, ECSE8035 page 86.

It's composed by two push buttons, that are electrically and mechanically distinct: It encloses in one module the functions of two distinct push buttons. It's used in signal systems or similar applications.

CABLAGGIO DEGLI APPARECCHI DI COMANDO ILLUMINABILI WIRING OF LIGHT CONTROL DEVICES

ECL4012 TEC, ECL4013 TEC, ECL4016 TEC, ECL4015 TEC, ECL4018 TEC, ECL4000 LN, ECL4000 LD, ECL4000 LD12 pag. 10, ECL4012 WH, ECL4013 WH, ECL4016 WH, ECL4015 WH, ECL4018 WH, ECL4000 LN, ECL4000 LD, ECL4000 LD12 pag. 20, ECL4012, ECL4013, ECL4016, ECL4015, ECL4018, ECL4000 LN, ECL4000 LD, ECL4000 LD12 pag. 30, ECSE8001, ECSE8003, ECSE8012, ECSE8011, ECSE8005, ECL4000 LD12 pag. 86, ECL2500, ECL2503, ECL2506, ECL2509, ECL2521 pag. 98.

Gli apparecchi di comando della serie civili ELETTRICANALI sono predisposti per essere equipaggiati con una lampada spia (ECL4000LN-ECL4000LD-ECL4000LD12). La luce emessa è visibile, nella serie MYLIFE®, attraverso la lentina trasparente frontale incorporata nel copritasto e, nella serie TONDÒ®, direttamente attraverso il tasto di comando. Si possono ottenere 3 funzioni in relazione al collegamento effettuato, così come specificato nel prospetto sottostante:

ECL4012 TEC, ECL4013 TEC, ECL4016 TEC, ECL4015 TEC, ECL4018 TEC, ECL4000 LN, ECL4000 LD, ECL4000 LD12 page 10, ECL4012 WH, ECL4013 WH, ECL4016 WH, ECL4015 WH, ECL4018 WH, ECL4000 LN, ECL4000 LD, ECL4000 LD12 page 20, ECL4012, ECL4013, ECL4016, ECL4015, ECL4018, ECL4000 LN, ECL4000 LD, ECL4000 LD12 page 30, ECSE8001, ECSE8003, ECSE8012, ECSE8011, ECSE8005, ECL4000 LD12 page 86, ECL2500, ECL2503, ECL2506, ECL2509, ECL2521 page 98.

ELETTRICANALI switching devices are designed to be equipped with a lamp (ECL4000LN-ECL4000LD-ECL4000LD12). The light is visible, in MYLIFE® series, through a transparent lens located in keycaps, and, in TONDÒ® series, directly, through the switching device. It is possible getting 3 functions depending on the type of wiring, as described in the pattern below:

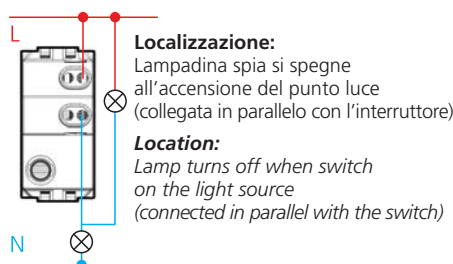
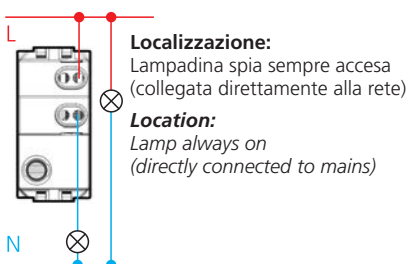

LIMITATORE DI SOVRATENSIONE VOLTAGE SURGE LIMITER

ECL4043 TEC pag. 11, ECL4043 WH pag. 21, ECL4043 pag. 31.

Il limitatore di sovratensione è un dispositivo, che abbinato alle prese di alimentazione delle utenze elettriche, è in grado di proteggere il carico connesso a queste prese dagli effetti dannosi derivanti dalle sovratensioni, principalmente di origine atmosferica o dovuti a manovre e/o comando di carichi induttivi allacciati.

L'apparecchio può essere utilizzato per la protezione delle prese di alimentazione di tutti i tipi di elettrodomestici ed in particolare di quelli contenenti componenti elettronici (Hi-Fi, TV, computer, videoregistratori, programmatori, registratori di cassa, Fax, ecc.).

ECL4043 TEC page 11, ECL4043 WH page 21, ECL4043 page 31.

Voltage surge limiter is a device which is capable of protecting appliances connected to a socket-outlet from damage resulting from overvoltage surges, mainly of atmospheric origin.

It would be used to protect sockets connected to different types of home appliances and electronic appliances (Hi-Fi, TV, PC, videorecorder, timer, cash register, fax, etc.).

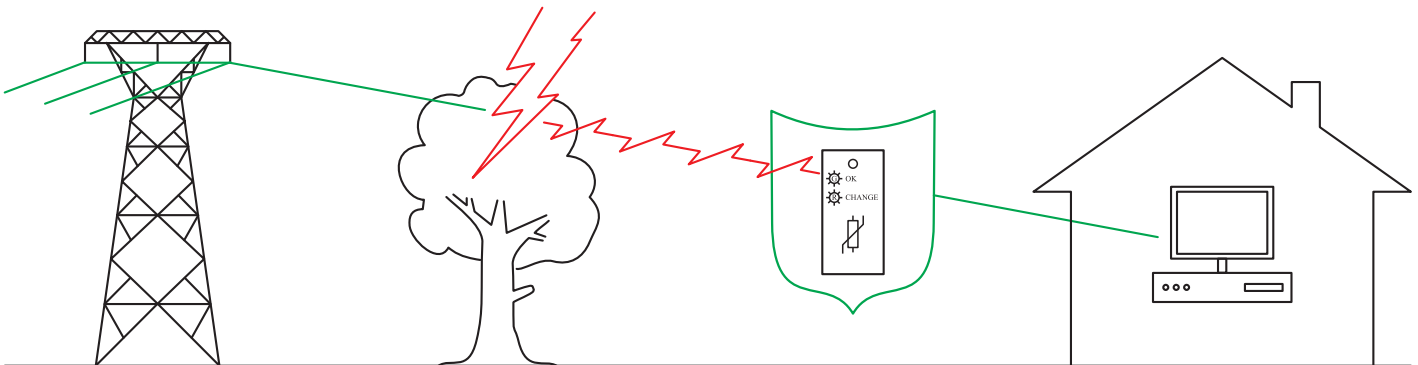

Il dispositivo offre esclusivamente una protezione per le sovratensioni che si generano tra conduttori attivi (tra fase e neutro) di tipo trasversale o di modo differenziale. Non è idoneo alla limitazione delle sovratensioni verso terra di tipo longitudinale o di modo comune.

The device, exclusively, offers a protection against over voltage surges arising between live conductors (phase – neutral) of transversal type or differential mode. It is not suitable for limitation of surges to earth of longitudinal type or common mode.

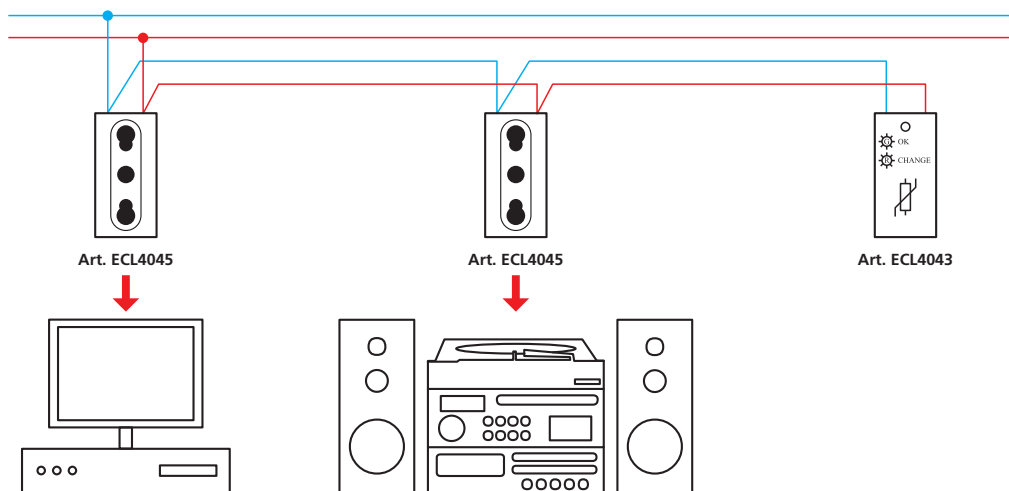

Il funzionamento ordinario del dispositivo è segnalato da un LED di colore verde. In caso di anomalia il LED di segnalazione diventa di colore rosso, la protezione non è più attiva e bisognerà quindi procedere alla sostituzione dell'apparecchio. L'alimentazione alle prese protette non viene mai interrotta.

If the led light is green, the device is protecting the charge connected to the socket. If the led light is red the protection is off and the limiter should be replaced with a new one. The charge connected to a protected socket never stops.

La protezione contro le sovratensioni in ambito domestico e similare si completa con il limitatore di sovratensione art. ECL4302 presente a pag. 105 realizzato per l'installazione nei centralini d'appartamento.

Protection against overvoltage surges in domestic range is completed with the overload limiter art. ECL4302 on pag. 105 realized for installation on flush mounting modular enclosures.

ULTERIORI CARATTERISTICHE

- Dispositivo di distacco: integrato
- Protezione associata: fusibile integrato
- Grado di protezione: IP20
- Sezione massima conduttori: 2,5 mmq
- Numero moduli: 1
- Temperatura di funzionamento: -5 °C / +45 °C
- Norme di riferimento: IEC 61643 - Direttiva BT

OTHER FEATURES

- Disconnecting device: include
- Protection: fuse include
- Protection degree: IP20
- Maximum cross-section of conductors: 2,5 mmq
- Modules: 1
- Operating temperature: -5 °C / +45 °C
- Rule compliance: IEC 61643

INTERRUTTORI AUTOMATICI MAGNETOTERMICI E MAGNETOTERMICI DIFFERENZIALI 1-2 MODULI
1-2 MODULES THERMAL-MAGNETIC AND DIFFERENTIAL THERMAL-MAGNETIC AUTOMATIC SWITCHES

ECL4400 TEC, ECL4401 TEC, ECL4402 TEC, ECL4403 TEC pag. 11,
ECL4400 WH, ECL4401 WH, ECL4402 WH, ECL4403 WH pag. 21,
ECL4400, ECL4401, ECL4402, ECL4403 pag. 31.

Gli interruttori automatici magnetotermici e gli interruttori magnetotermici differenziali proteggono contro le sovracorrenti e le correnti di guasto a terra dei circuiti terminali. Particolarmente adatti alla protezione di:

- Utenze terminali in locali dove è maggiore il rischio di elettrocuzione (bagni, cucine, docce);
- Prese di alimentazione di utenze di classe I con circuiti elettronici (computer e accessori, bilance elettroniche ecc.);

La parte elettromagnetica degli interruttori garantisce la protezione contro i sovraccarichi e i corto circuiti; la parte differenziale dei dispositivi, per valori di corrente di 10mA, assicura la protezione delle persone contro le tensioni di contatto.

ECL4400 TEC, ECL4401 TEC, ECL4402 TEC, ECL4403 TEC page 11,
ECL4400 WH, ECL4401 WH, ECL4402 WH, ECL4403 WH page 21,
ECL4400, ECL4401, ECL4402, ECL4403 page 31.

The automatic thermal overload protection switches and the automatic residual current switches protect against current surges and earth fault currents of terminal circuits. They are particularly suitable to protect:

- Terminal devices where there is a greater risk of electrocution (baths, kitchen, showers);
- Socket that supply class I devices with electronic circuit (PC and accessories, electronic scales, etc);

Electromagnetic part of circuit breakers ensures protection against overloads and short-circuits, the residual current protection of the devices, for current values of 10mA, ensures protection of people against contact voltages.

CARATTERISTICHE ELETTRICHE TECHNICAL FEATURES					
Tipo di interruttore Type of circuit-breaker	Magnetotermico Thermal-magnetic	Magnetotermico differenziale Differential thermal-magnetic	Tipo di interruttore Type of circuit-breaker	Magnetotermico Thermal-magnetic	Magnetotermico differenziale Differential thermal-magnetic
Tensione nominale Rated voltage	230V~	230V~	Numero poli Number of poles	1P + N	1P + N
Frequenza nominale Rated frequency	50 ÷ 60Hz	50 ÷ 60Hz	Caratteristiche d'intervento Intervention features		
Corrente nominale differenziale Residual rated current	-	-	- Protezione sovracorrenti - Current surge protection	Tipo C C Type	Tipo C C Type
Potere di cortocircuito Short-circuit power	10A 3000A 16A 3000A	10A 3000A 16A 3000A	- Classe di limitazione - Limitation class	3	3
Correnti nominali Rated currents	10 - 16A	10 - 16A	- Protezione differenziale - Residual current protection	-	Classe A A class

CARATTERISTICHE FEATURES

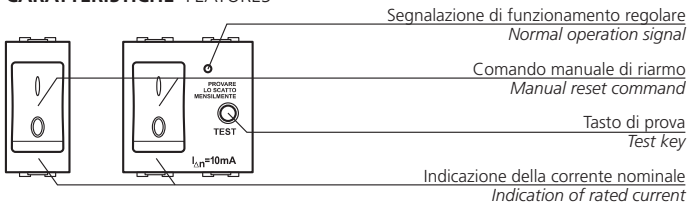

- Tensione di alimentazione: 120-230V+-10% 50-60Hz
- Organo di comando principale a leva: simbolo "I" (circuito chiuso) simbolo "O" (circuito aperto)
- Led frontale a luce verde per segnalazione presenza di tensione di rete e circuito chiuso (solo ECL4402-ECL4403)
- Tasto di prova giallo per la verifica del corretto funzionamento del dispositivo
- Controllo della temperatura interna: al superamento della soglia di sicurezza, opera automaticamente l'apertura del circuito
- Controllo della continuità elettrica del circuito interno differenziale con apertura dell'interruttore al mancare della continuità (solo ECL4402 - ECL4403)
- Intervento over-voltage: la presenza all'ingresso dell'interruttore, di tensioni superiori alla soglia fissata provoca l'apertura del circuito
- Morsetti protetti con viti imperdibili per il serraggio di due conduttori fino a 4 mm² ciascuno
- Costruzione della parte magnetotermica secondo quanto prescritto dalle norme EN 60898 e IEC 60898
- Costruzione della parte differenziale secondo quanto prescritto dalle norme EN 61009 e IEC 61009

ESEMPIO D'APPLICAZIONE APPLICATION EXAMPLE

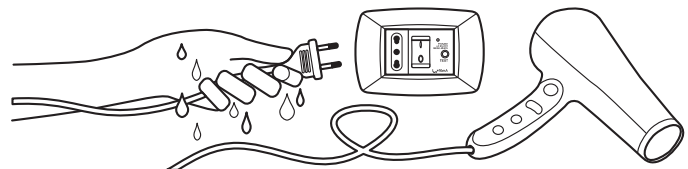

- Supply voltage: 120-230V+-10% 50-60Hz
- Main operating lever mechanism: "I" symbol (closed circuit) symbol "O" (open circuit)
- Green front LED indicating normal operation: main power and closed circuit (only ECL4402 - ECL4403)
- Yellow test key for testing correct operation of the device
- Internal temperature control: circuit breaker operating automatically opens circuit when threshold is exceeded
- Autotest function for testing electrical continuity of residual current internal circuit (only ECL4402 and ECL4403)
- Opening of the circuit if voltage is greater than the threshold voltage at the circuit-breaker input
- Protected terminals with captive screws for tightening two conductors to 4mm² each
- Construction of magnetothermal part in appliance of EN 60898 e IEC 60898
- Construction of differential part in appliance of EN 61009 e IEC 61009

SCHEMA DI COLLEGAMENTO ED INSTALLAZIONE WIRING DIAGRAM AND INSTALLATION

La linea di alimentazione può essere collegata indifferentemente ai morsetti superiori o inferiori. Deve essere installato a valle di un interruttore differenziale in accordo alle norme impianti CEI 64-8/5. Il funzionamento dipende dalla tensione di rete.

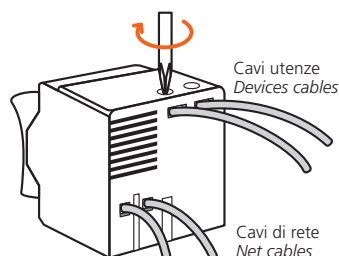

The power line can be connected both upper terminal and lower ones of circuit breaker, which must be installed downstream of a main residual current circuit breaker according CEI 64-8/5 rule. The supply voltage causes the operation.

PRESE TELEFONICHE TELEPHONE SOCKETS

ECL4084 TEC pag. 12, ECL4084 WH pag. 22, ECL4084 pag. 32,
ECL4082 TEC pag. 12, ECL4082 WH pag. 22, ECL4082 pag. 32,
ECL4082 WHAB pag. 43, ECSE8989C4 pag. 88, ECL2584 pag. 99.

ECL4084 TEC page 12, ECL4084 WH page 22, ECL4084 page 32,
ECL4082 TEC page 12, ECL4082 WH page 22, ECL4082 page 32,
ECL4082 WHAB pag. 43, ECSE8989C4 pag. 88, ECL2584 page 99.

RJ11

La sigla RJ-11 (Registered Jack tipo 11) identifica una specifica modalità di cablaggio che prevede l'uso di una sola coppia di conduttori attestata sui contatti centrali (3 e 4), per il collegamento di apparecchi telefonici e similari (fax, modem).

RJ11

RJ11 (Registered jack 11) is a standardized physical network interface that allows the use of only one couple of connectors on two central switches (3-4), for connecting telecommunications.

RJ12

Le versioni che utilizzano più coppie di conduttori sono cablate a partire dal centro verso l'esterno e assumono nomi diversi a seconda del numero di coppie attestate e dell'applicazione: la versione con tutte le 6 posizioni collegate, va sotto il nome di RJ-12 e viene utilizzata per la connessione di impianti telefonici interni intercomunicabili.

RJ12

The versions, that use more couples of connectors, are cabling from center toward the outside, and are calling with different names according the number of connectors used and their application: the version characterized by the connection of all 6 switches is RJ12 and it is used for connecting internal telephone system.

PRESE TELEFONICHE - SCHEMI DI COLLEGAMENTO TELEPHONE SOCKETS - CONNECTION PATTERNS

Schemi di collegamento più comuni realizzati con l'uso dei connettori RJ11 per un ampliamento di un impianto domestico esistente o per la predisposizione di uno nuovo.

Common connection patterns, realised with RJ11 to widen a domestic system or to generate a new one.

Collegamento in serie

Segreto di conversazione

In series connection

Secret conversation

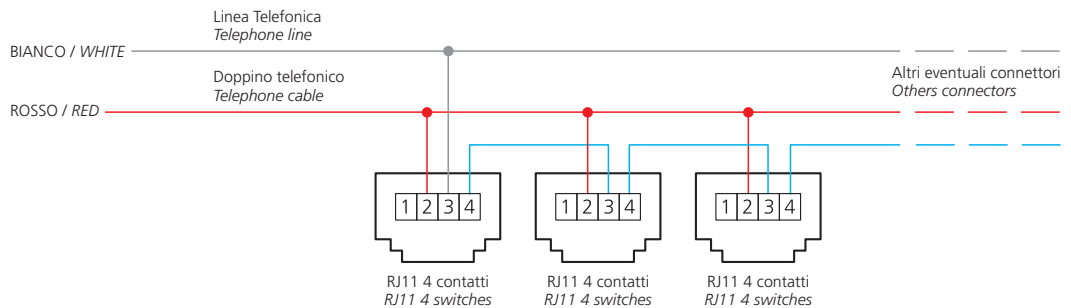

Lo sgancio del ricevitore interrompe la linea a valle garantendo il segreto di conversazione.

The release of the receiver breaks the downstream line ensuring the secrecy of conversation.

NOTA: l'assenza di un apparecchio in una presa determina l'assenza di linea a valle nelle prese. Si ovvia inserendo una spina vuota con un ponticello tra i morsetti 3 e 4.

NOTE: the absence of a device determines the absence of downstream line into the sockets. It compensates by inserting a blank plug with a jumper between terminals 3 and 4.

Collegamento in parallelo

No segreto di conversazione

In parallel connection

No secret conversation

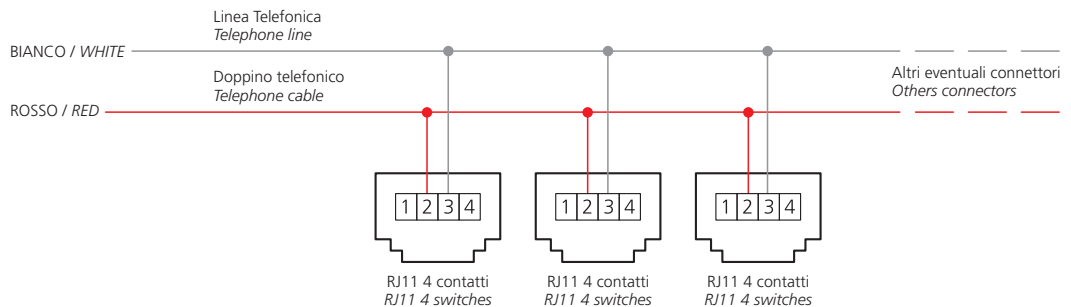

Per la presa ECL4082 i morsetti da usare sono il 3 e il 4, ovvero i morsetti centrali.

For socket ECL4082, use two central terminals 3 and 4.

PRESE DATI DATA SOCKETS

ECL4083 TEC pag. 12, ECL4083 WH pag. 22, ECL4083 pag. 32,
ECL4085 TEC pag. 12, ECL4085 WH pag. 22, ECL4085 pag. 32,
ECL4086 TEC pag. 12, ECL4086 WH pag. 22, ECL4086 pag. 32,
ECL4087 TEC pag. 12, ECL4087 WH pag. 22, ECL4087 pag. 32,
ECL4083 WHAB pag. 43,
ECSE8989C5, ECSE8989C8, ECSE8989C6, ECSE8989C7 pag. 88,
ECL2583, ECL2585, ECL2586, ECL2587 pag. 99.

ECL4083 TEC page 12, ECL4083 WH page 22, ECL4083 page 32,
ECL4085 TEC page 12, ECL4085 WH page 22, ECL4085 page 32,
ECL4086 TEC page 12, ECL4086 WH page 22, ECL4086 page 32,
ECL4087 TEC page 12, ECL4087 WH page 22, ECL4087 page 32,
ECL4083 WHAB page 43,
ECSE8989C5, ECSE8989C8, ECSE8989C6, ECSE8989C7 page 88,
ECL2583, ECL2585, ECL2586, ECL2587 page 99.

UTP-FTP

L'acronimo UTP, Unshielded Twisted Pair, identifica una presa non schermata utilizzata comunemente per il collegamento nelle reti ethernet.

Al contrario l'acronimo FTP, Foiled Twisted Pair, identifica una presa schermata ovvero realizzata con un materiale conduttivo che funge da schermo per le onde elettromagnetiche e per le interferenze.

Le prese UTP e FTP seguono le specifiche standardizzate in TIA/EIA che li dividono in varie categorie in base alle capacità di trasportare segnali.

Le categorie vanno da 1 a 7.

UTP-FTP

UTP acronym, Unshielded Twisted Pair, describes an unshielded socket used in computer networking. Modern ethernet, the most common data networking standard, utilizes UTP sockets.

Opposite, FTP acronym, Foiled Twisted Pair, describes a shielded socket, realized with a conductive metal that produces a protection against electromagnetic interference.

UTP and FTP sockets, according to the standard TIA/EIA, are divided in some different classes on the strength of their capability to bring signals.

There are seven classes from 1 to 7.

CATEGORIA 5e

Usata per reti con frequenze fino a 120 MHz, ovvero per la trasmissione dati di apparecchi informatici (modem, computer, stampanti, fast ethernet).

5e CLASS

Used in networks with a frequency until 120 MHz to drive data in information appliances (modem, pc, printer, fast ethernet).

CATEGORIA 6

Usata per reti con frequenze fino a 250 MHz, ovvero per la trasmissione dati di dispositivi multimediali (videoconferenze).

6 CLASS

Used in networks with a frequency until 250 MHz to drive data in multimedia appliances (video conference).

RJ45

La sigla RJ-45 (Registered Jack tipo 45) identifica un connettore modulare 8P8C, ovvero a 8 posizioni e 8 contatti (pin), che viene utilizzato nei sistemi dei servizi telefonici e di trasmissione dati.

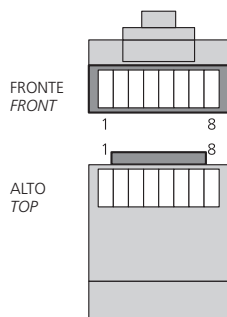

RJ45

RJ-45 (Registered Jack 45) is an unkeyed, 8 pin and 8 connectors, which specifies the physical male and female connectors as well as the pin assignments of the wires in a telephone cable.

It is used in systems for telephone service and data transmission.

Per tale applicazione sono stati sviluppati due standard di cablaggio, EIA/TIA-568A ed EIA/TIA-568B, che definiscono l'assegnazione dei connettori (pin) presenti sulla presa RJ45 con i cavi conduttori.

There are two cabling standards for this type of connector: EIA/TIA-568A and EIA/TIA-568B. These two standards define the pin/pair assignments for eight-conductor 100-ohm balanced twisted pair cabling.

Cablaggio per connettore RJ-45 secondo gli standard EIA/TIA-568A/B

RJ45 cabling according to EIA/TIA-568A/B standards

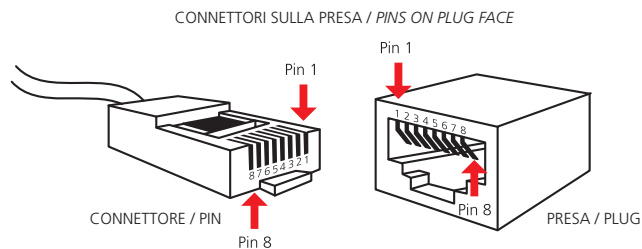

Pin	Cp. T568A	Cp. T568B	Codice colori T568A / Colours code T568A	Codice colori T568B / Colours code T568B
1	3	2	bianco verde / white green	bianco arancio / white orange
2	3	2	verde / green	arancio / orange
3	2	3	bianco arancio / white orange	bianco verde / white green
4	1	1	blu / blue	blu / blue
5	1	1	bianco blu / white blue	bianco blu / white blue
6	2	3	arancio / orange	verde / green
7	4	4	bianco marrone / white brown	bianco marrone / white brown
8	4	4	marrone / brown	marrone / brown

PRESE DATI - ISTRUZIONI PER L'INSTALLAZIONE DATA SOCKETS - KEYSTONE JACK INSTALLING INSTRUCTION

1

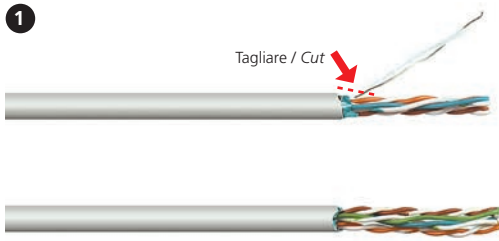

Togliere la plastica approssimativamente su 40 mm di cavo
Strip approximately 40 mm of the cable jacket and cut off the plastic cross

3

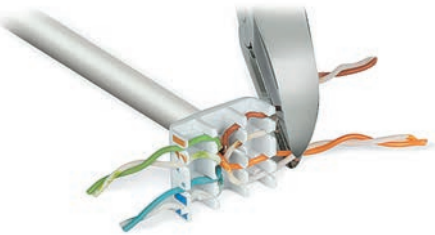

Seguire il codice colore per inserire il filo nelle fessure della presa.
Tenere le coppie unite il più possibile e tagliare il filo in eccesso
*Follow the cap color code to place the wires into the cap slot.
Keep the pairs twisted as possible as you can and cut off the surplus wires*

5

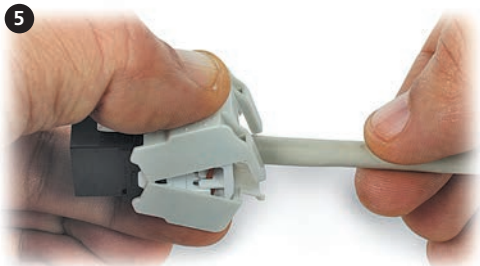

Chiudere i due tappi con un "click" per una connessione sicura
Lock the side caps with "click" means successful connection

2

SEQUENZA D'INTRODUZIONE DEI CAVI
T568A

Pin 5 bianco blu / *white blue*
Pin 4 blu / *blue*
Pin 1 bianco verde / *white green*
Pin 2 verde / *green*
Pin 3 bianco arancio / *white orange*
Pin 6 arancio / *orange*
Pin 7 bianco marrone / *white brown*
Pin 8 marrone / *brown*

PUNCHDOWN SEQUENCE
T568A

Pin 5 bianco blu / *white blue*
Pin 4 blu / *blue*
Pin 1 bianco arancio / *white orange*
Pin 2 arancio / *orange*
Pin 3 bianco verde / *white green*
Pin 6 verde / *green*
Pin 7 bianco marrone / *white brown*
Pin 8 marrone / *brown*

4

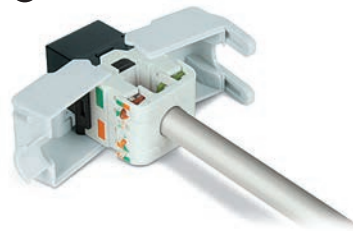

Seguire il segno del colore per mettere la chiusura sulla presa
Follow the color sign to put the cap onto IDC

6

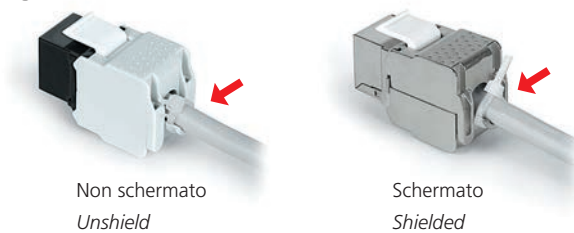

Chiudere la fascetta e terminare
Connect the drain wire to the shielded shell

SCHEMI DIMOSTRATIVI DI IMPIANTI SAT E TV DEMONSTRATIVE PATTERNS OF SAT-TV SYSTEMS

ECL20483 pag. 12, 22, 32, 88, 99,
ECL4051 TEC, ECL4054 TEC, ECL4055 TEC, ECL4056 TEC, ECL4052 SATEC, ECL4057 SATEC, ECL4058 FMSATEC, ECL4053 SATEC, ECL4100 TEC, ECL4101 TEC pag. 13,
ECL4051 WH, ECL4054 WH, ECL4055 WH, ECL4056 WH, ECL4052 SATWH, ECL4057 SATWH, ECL4058 FMSATWH, ECL4053 SATWH, ECL4100 WH, ECL4101 WH pag. 23,
ECL4051, ECL4054, ECL4055, ECL4056, ECL4052 SAT, ECL4057 SAT, ECL4058 FMSAT, ECL4053 SAT, ECL4100, ECL4101 pag. 33,
ECSE8173D, ECSE8173P, ECSE8174P, ECSE8175P, ECSE8172D, ECSE8172P, ECSE8173F pag. 89, ECL2551, ECL2552 SAT, ECL2553 SAT pag. 99.

Gli schemi riportati hanno uno scopo esclusivamente dimostrativo per cui la scelta degli articoli dipende dal valore della potenza del segnale dell'impianto in cui si opera.

IMPIANTO SAT / SAT SYSTEM Singolo utente / One user

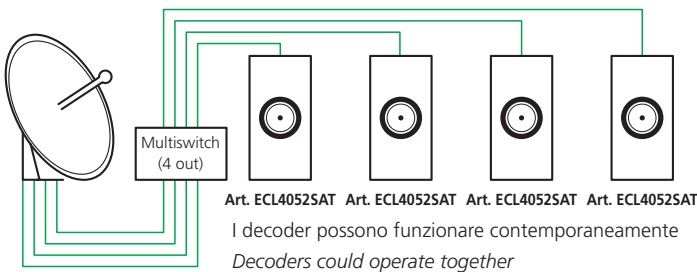

ECL20483 page 12, 22, 32, 88, 99,
ECL4051 TEC, ECL4054 TEC, ECL4055 TEC, ECL4056 TEC, ECL4052 SATEC, ECL4057 SATEC, ECL4058 FMSATEC, ECL4053 SATEC, ECL4100 TEC, ECL4101 TEC page 13,
ECL4051 WH, ECL4054 WH, ECL4055 WH, ECL4056 WH, ECL4052 SATWH, ECL4057 SATWH, ECL4058 FMSATWH, ECL4053 SATWH, ECL4100 WH, ECL4101 WH page 23,
ECL4051, ECL4054, ECL4055, ECL4056, ECL4052 SAT, ECL4057 SAT, ECL4058 FMSAT, ECL4053 SAT, ECL4100, ECL4101 page 33,
ECSE8173D, ECSE8173P, ECSE8174P, ECSE8175P, ECSE8172D, ECSE8172P, ECSE8173F page 89, ECL2551, ECL2552 SAT, ECL2553 SAT page 99.

The patterns shown have only a demonstrative scope, consequently devices chosen depends from signal power of system in which operates.

IMPIANTO SAT / SAT SYSTEM Singolo utente / One user

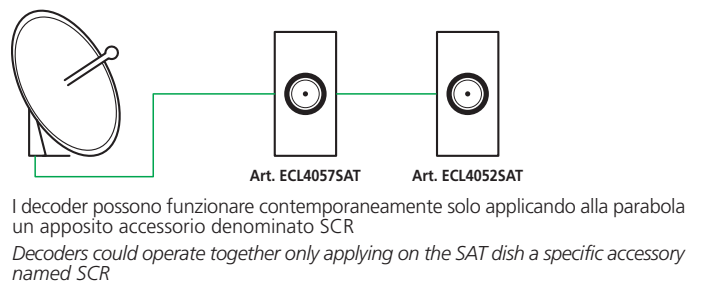

IMPIANTO TV-SAT / TV-SAT SYSTEM Singolo utente / One user

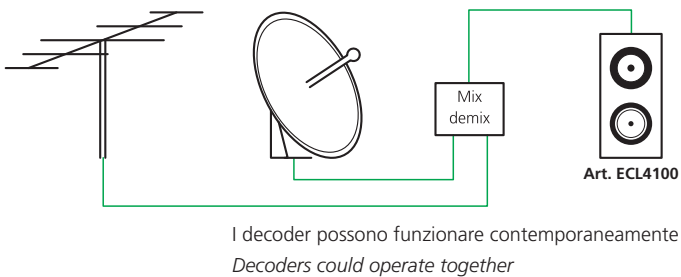

IMPIANTO TV-SAT / TV-SAT SYSTEM Singolo utente / One user

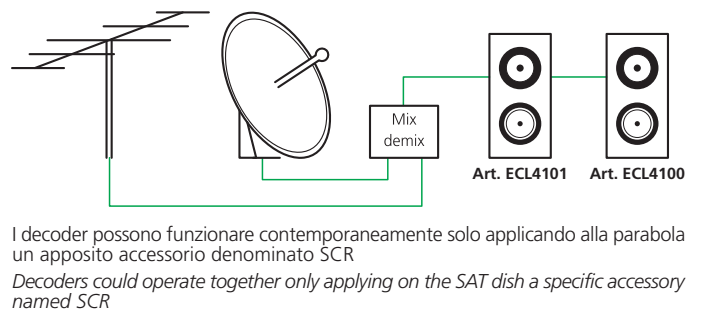

IMPIANTO TV CON DISTRIBUZIONE A CASCATA TV SYSTEM WITH FALL DISTRIBUTION Singolo utente / One user

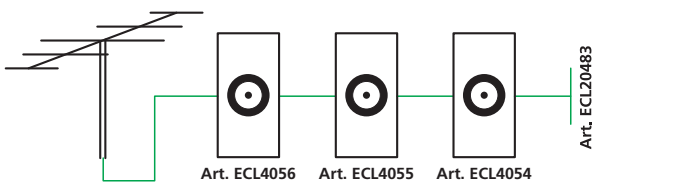

IMPIANTO TV CON DISTRIBUZIONE A CASCATA TV SYSTEM WITH FALL DISTRIBUTION Singolo utente / One user

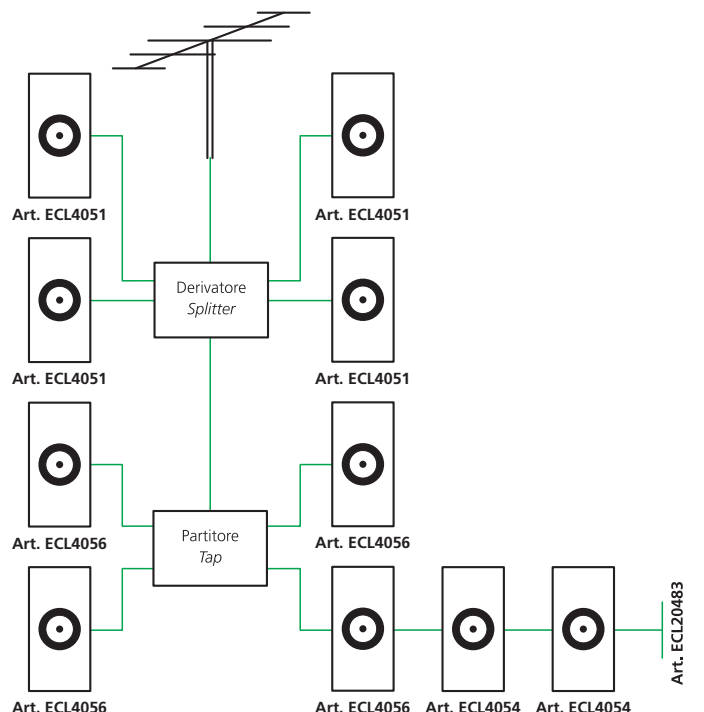

IMPIANTO TV-SAT-RADIO / TV-SAT-RADIO SYSTEM Singolo utente / One user

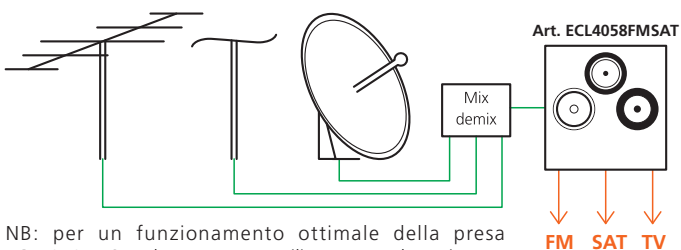

NB: per un funzionamento ottimale della presa ECL4058FMSAT devono essere utilizzate tutte le uscite.
Note: for the best mode of operation of socket ECL4058FMSAT is necessary that all output are working.



INTERRUTTORE AUTOMATICO AD INFRAROSSO PASSIVO PASSIVE INFRARED AUTOMATIC SWITCH

ECL4065 TEC pag. 13, ECL4065 WH pag. 23, ECL4065 pag. 33.

L'interruttore passivo ad infrarosso attiva automaticamente il carico quando individua una variazione termica provocata dal movimento di persone o altro entro la zona di copertura.

È costituito da un temporizzatore interno, che permette di impostare il tempo in cui le luci rimarranno accese dopo che è stato rilevato il movimento, e da un sensore crepuscolare che permette di regolare la soglia minima in corrispondenza della quale il carico è acceso.

PRINCIPALI FUNZIONI:

- Identifica il giorno e la notte automaticamente.
- Il tempo di accensione è aggiornato continuamente: riparte sempre dall'ultima regolazione effettuata.

ECL4065 TEC page 13, ECL4065 WH page 23, ECL4065 page 33.

Infra-red switch automatically controls electric load, when the infra-red detector perceives some heat variations caused by the movement of people or other within the covered area.

It's composed by an internal timer that allows to plan the time in which the lights will remain on after the movement detection, and by a twilight sensor that allows to control the minimum line by which the load is on.

MAIN FUNCTIONS:

- Automatically it recognizes day and night.
- Switching on time is continuously update: it everyday restarts from last regulation.

REGOLAZIONE LUMINOSITÀ E TEMPORIZZAZIONE LIGHTNESS AND TIMING CONTROL

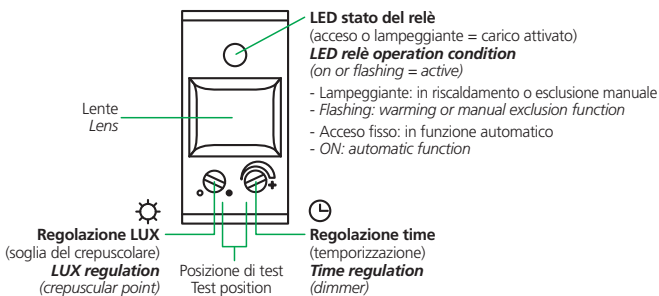

	Senso antiorario Anticlockwise	Regolazione intermedia Intermediate regulation	Senso orario Cock wise
Luminosità Lightness	Acceso solo al buio ON only in the dark	Crepuscolare Twilight	Sempre attivo Everyday ON
Temporizzazione Timing	5 sec. ca.	6 min. ca.	12 min. ca.

CAMPO DI IMPIEGO

Viene generalmente utilizzato in ambienti di passaggio come corridoi, ingressi e simili per accendere automaticamente una luce al transito di persone e/o cose.

APPLICATION

Generally it's used in passing places as corridor, admission and similar to on automatically a light when people or things are passing in them.

SCHEMA DI COLLEGAMENTO CONNECTION LAYOUT

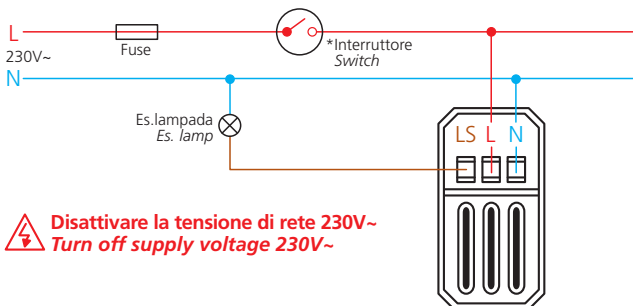

Disattivare la tensione di rete 230V~
Turn off supply voltage 230V~

Nota: al rilevatore è possibile collegare un *interruttore a parete per permettere il funzionamento "esclusione manuale".

COPERTURA VOLUMETRICA: installazione h 1,0÷1,2 m
VOLUMETRIC COVERAGE: installation h 1,0÷1,2 m

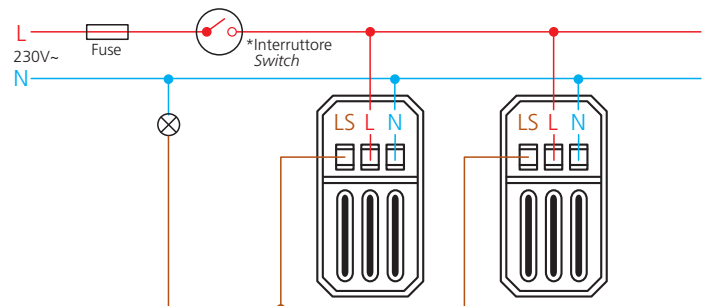
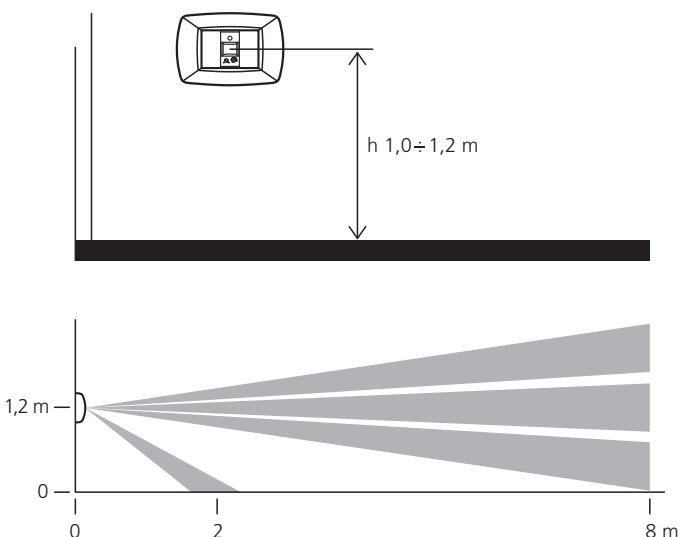

Note: it is possible to connect a *switch to detector to allow the function "manual exclusion".

Prima dell'installazione, tenere conto del fatto che il rilevatore è più sensibile ai movimenti che attraversano il suo campo d'azione → e meno sensibile ai movimenti in direzione del rilevatore stesso →.

Before installing, it is important to consider that the detector is more perceptive to movements that cross its action field → and it is less perceptive to movement that go in its direction →.

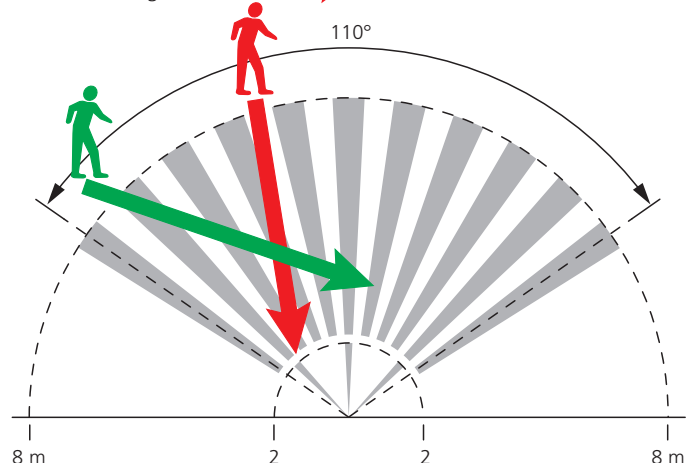

CRONOTERMOSTATO SETTIMANALE DIGITALE 3 MODULI DA INCASSO 3 MODULES WEEKLY DIGITAL THERMOSTAT



Il kit comprende 3 cover colorate:
TEC - BIANCA - GRIGIA
The kit is composed by 3 coloured covers:
TEC - WHITE - GREY



ECL4062L pag. 14, 24, 34.

Cronotermostato elettronico a microprocessore, con programmazione settimanale per il comando di impianti di riscaldamento e di condizionamento.

CARATTERISTICHE ELETTRICHE

Scala di regolazione temperatura: 2-40°C
Scala visualizzata temperature: -35 +60°C
Portata contatti: 5(3)A 250V~.
Alimentazione: senza connessioni alla linea elettrica con 2 pile a stilo alcaline AAA (1.5V)
Software: classe A
Microdisconnessione: (1BU)
Dimensioni: 68x52.5x58 mm

INSTALLAZIONE E FUNZIONAMENTO

Montaggio da incasso in scatole a 3 moduli tipo 503 mediante 2 viti (a corredo).
Collegamento all'utilizzatore con 2 fili.
Montare il cronotermostato a 1,5 metri di altezza dal pavimento, lontano da cucine, fonti di calore, finestre e porte.
Si possono applicare la placca Mylife e la placca New Prestige.
Con ECL4062L è possibile estrarre il corpo del cronotermostato dal telaio dopo il fissaggio ed i collegamenti per poter fare più comodamente la regolazione o la programmazione con l'apparecchio in mano.
Il cronotermostato dispone di 6 tasti frontali per accedere direttamente ai modi di funzionamento modificabili tramite la pressione del tasto corrispondente.

VISUALIZZAZIONE SUL DISPLAY

Temperatura ambiente
Ora in corso
Profilo di temperatura visualizzato tramite istogramma
6 icone per la programmazione

NORMATIVE E OMOLOGAZIONI

EN 60730-2-9

ECL4062L page 14, 24, 34.

Electronic chronothermostat with microprocessor, with weekly programming, to control heating and air-conditioning installations.

TECHNICAL FEATURES

Temperature adjustment range: 2-40°C
Ambient temperature displaying range: -35 +60°C
Contact capacity: 5(3)A 250V~.
Power supply: without any connection to the line with 2 AAA alkaline batteries (1.5V)
Software: A class
Type of action: (1BU)
Dimension: 68x52.5x58 mm

INSTALLATION AND OPERATION

Flush-mounting in 3-modules 503 embedded boxes by means of 2 screws (supplied).
Two-wire connection with the user.
Install the chronothermostat at 1,5 meters above the floor, away from kitchens, heat sources, windows and doors.
Can be applied the following plates Mylife and New Prestige.
With ECL4062L is possible to extract chronothermostat's body from the frame after mounting and connections, this for doing more easily the adjusting or programming with the device in hand.
The chronothermostat has 6 front keys to access directly the operating modes that can be changed by pressing the corresponding key.

DISPLAY VISUALIZATION

Ambient temperature
Current time
Temperature profile shown by means of histogram
6 icons for programming

RULES ACCOMPLIANCE

EN 60730-2-9

TERMOSTATO AMBIENTE ELETTRONICO 3 MODULI DA INCASSO 3 MODULES ELECTRONIC THERMOSTAT



ECL4063L TEC pag. 14, ECL4063L WH pag. 24, ECL4063L pag. 34.

Termostato ambiente elettronico da incasso per la regolazione della temperatura in impianti di riscaldamento e condizionamento, civili e industriali.

CARATTERISTICHE ELETTRICHE

Scala di regolazione temperatura: 5-30°C
Temperatura ammissibile corpo: -10 +50°C
Portata contatti: 5(3)A 250V~
Alimentazione: senza connessioni alla linea elettrica con 3 pile a microstilo alcaline AAA (1.5V)
Microdisconnessione: (1BU)

INSTALLAZIONE E FUNZIONAMENTO

Montaggio da incasso in scatole a 3 moduli tipo 503 mediante 2 viti (a corredo).
Collegamento all'utilizzatore con 2 fili.
Si possono applicare la placca Mylife e la placca New Prestige.
All'aumento della temperatura: apre 1-2.

CARATTERISITCHE

Commutatore Estate-Inverno
Manopola di regolazione di grande diametro e ampia scala
Doppio isolamento
Tasto di prova per verificare la carica delle pile
Le pile sono estraibili dal frontale del termostato

NORMATIVE E OMOLOGAZIONI

EN 60730-2-9

ECL4063L TEC page 14, ECL4063L WH page 24, ECL4063L page 34.

Flush-mounting room thermostat to control heating and air-conditioning installations.

TECHNICAL FEATURES

Temperature adjustment range: 5-30°C
Body admissible temperature: -10 +50°C
Contact capacity: 5(3)A 250V~
Power supply: without any connection to the line with 3 micro AAA alkaline batteries (1.5V)
Type of action: (1BU)

INSTALLATION AND OPERATION

Flush-mounting in 3-module 503 embedded boxes by means of 2 screws (supplied).
Two-wire connection with the user.
Can be applied the following plates Mylife and New Prestige.
Temperature increase: open 1-2.

FEATURES

Summer-Winter 1 way switch
Adjustment knob with large diameter, wide range
Double insulation
Key test to check battery charge
Batteries are extractable from thermostat front

RULES ACCOMPLIANCE

EN 60730-2-9

INTERRUTTORE A BADGE E TESSERA TRANSPONDER BADGE SWITCH AND TRANSPONDER CARD

**ECL4026 pag. 14 e 34, ECL4026 WH pag. 24,
ECL4026T pag. 14, 24, 34.**

Il riconoscitore è utilizzato per attivare i servizi all'interno della camera mediante una tessera trasponder.

Con il riconoscitore non c'è la lettura della tessera, viene garantito comunque il riconoscimento di qualsiasi tipo di tessera trasponder. È inoltre possibile settare un tempo di cortesia per la disattivazione della camera al disinserimento della tessera. (settaggio realizzabile mediante ponticelli di configurazione).

PRINCIPALI FUNZIONI

- Montaggio da incasso in scatola a 3 moduli tipo 503 mediante 2 viti e supporto (a corredo);
- Riconoscimento di tessere di tipo ISO14443A, ISO14443B, ISO15693;
- 1 uscita per l'abilitazione dei servizi di camera;
- 1 uscita replicata a relay stato solido per altre attivazioni
- Luce led blu come guida per la fessura di inserimento tessera;
- 1 luce Led rossa lampeggiante quando la tessera non è inserita, spenta all'inserimento;
- Tempo di cortesia programmabile da 10s a 30s;
- Compatibile con tessere transponder utilizzate da sistemi di serratura elettronica per hotel: CISA, SALTO, Vingcard/Assa Abloy, DormaKaba.

PANNELLO COMANDI

- A: Led rosso (di default led presenza cliente);
- B: fessura inserimento tessera.

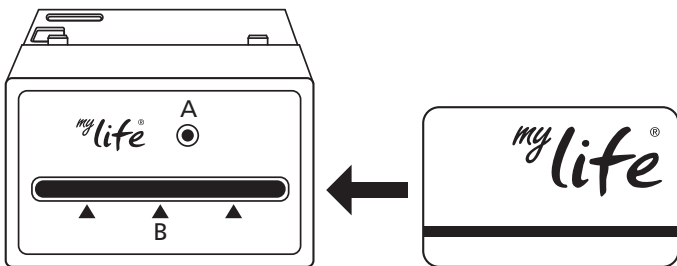

**ECL4026 pag. 14 e 34, ECL4026 WH pag. 24,
ECL4026T pag. 14, 24, 34.**

This device (commonly named recognizer) is used to activate services inside the room using a transponder card (badge).

With the recognizer there is no card reading; anyway, the recognition of any type of transponder card is guaranteed. Possibility to set a "courtesy time" when card is removed (settable via jumper setting).

MAIN FUNCTIONS

- Flush mounting in 3 modules 503 embedded boxes by means of 2 screws and wall frame (supplied);
- Compatibility card type: ISO14443A, ISO14443B, ISO15693;
- 1 relay output for room services enabling;
- 1 replicated solid state relay output for other activations;
- Blue Led light guide in the card insertion slot;
- 1 presence's Led that blinks when card is not inserted. Led is off when card is inserted (default function);
- Courtesy time programmable from 10s to 30s;
- Compatible with transponder cards used by electronic lock systems for hotel: CISA, SALTO, Vingcard/Assa Abloy, DormaKaba.

CONTROL PANEL

- A: red Led (default: presence/absence of the card in the device);
- B: card insertion slot.

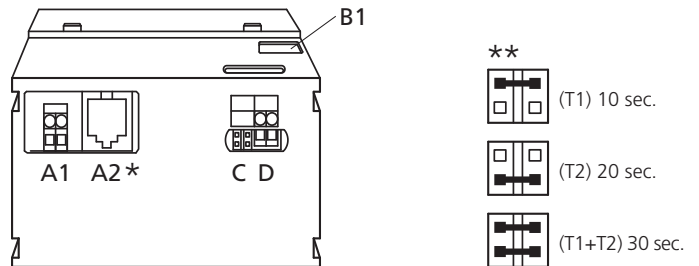

CONNESSIONI

- A1: connettore a vite per l'alimentazione del modulo;
- A2: non utilizzato (*);
- B1: spinotto estraibile per contatto relè 3A-230V~;
- C: jumper configurabili T1, T2 per tempo di cortesia. Per i tempi di cortesia ponticellare come da figura (**);
- D: connettore a vite per R1.R2 - contatto pulito (max. 60Vdc @ 0.1A);

CONNECTIONS

- A1: screw connector for powering up the device +24Vdc (respect polarity);
- A2: not used (*);
- B1: removable plug for relay 3A-230V~ contact;
- C: configurable jumper T1, T2 for courtesy time. Settings jumper configuration for courtesy time (**);
- D: screw connector for R1,R2 - solid state relay contact (max. 60Vdc @ 0.1A);

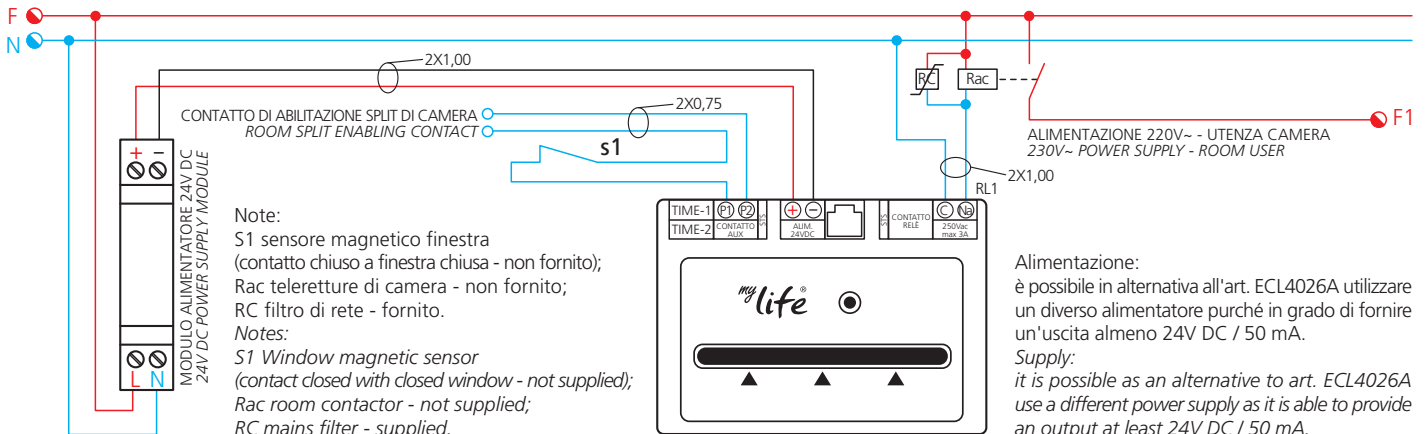

SPECIFICHE TECNICHE

- Tensione di alimentazione: 24Vdc (+/- 20%);
- Assorbimento: min 10mA - max 35mA (@24Vdc);
- Uscite: 1 relay 3A-230V~ su carico resistivo;
- 1 uscita replicata di tipo relay stato solido - max. 60Vdc@0.1A;
- Protezione: IP 20;
- Servizio di funzionamento: di tipo continuo (alimentazione deve sempre essere presente).
- Compatibilità tessere: ISO14443A, ISO14443B, ISO15693;
- Frequenza trasponder: 13,56MHz;
- Temperatura d'utilizzo: - 10°C / 50°C;
- Umidità relativa senza condensa: 5% - 90%;
- Protezione vs. inversione polarità alim.: diodo in serie;
- Sicurezza elettrica: EN 60950-1;
- Compatibilità elettromagnetica: EN 55024, EN 61000-6-1, EN 55022, EN 61000-6-3, EN 301-489-1, EN 301-489-3, EN 300-330-1, EN 300-330-2, EN 302-291-1, EN 302-291-2;
- Conforme direttive UE: 2014/35/CE (LVD) - 2014/30/CE (EMC) 1999/5/CE (R&TTE) - 2011/65/UE (RoHS) E - 2011/65/UE (RoHS).

TECHNICAL SPECIFICATIONS

- Power Voltage: 24Vdc (+/- 20%);
- Power consumption: min 10mA - max 35mA (@ 24Vdc);
- Output: 1 relay 3A@230V~ (resistive load);
- 1 replicated output: solid state relay type - max. 60Vdc@0.1A;
- IP Protection: IP 20;
- Operation service: continuous (power must be always on);
- Card compatibility: ISO14443A, ISO14443B, ISO15693;
- Transponder card frequency: 13,56MHz;
- Operating temp.: - 10°C / 50°C;
- Operating humidity without condensation: 5% - 90%;
- Protection vs. power reverse polarity: diode in series;
- Electrical safety: EN 60950-1;
- Electromagnetic compatibility: EN 55024, EN 61000-6-1, EN 55022, EN 61000-6-3, EN 301-489-1, EN 301-489-3, EN 300-330-1, EN 300-330-2, EN 302-291-1, EN 302-291-2;
- Conforms to EU directives: 2014/35/CE (LVD) - 2014/30/CE (EMC) 1999/5/CE (R&TTE) - 2011/65/UE (RoHS) E - 2011/65/UE (RoHS).

VARIATORI DI LUMINOSITÀ PUSH-PUSH LIGHT DIMMERS PUSH ACTION

ECL4705 TEC pag. 14, ECL4705 WH pag. 24, ECL4705 pag. 34,
ECL4705 WHAB pag. 43,
ECL4701 TEC e ECL4702 TEC pag. 14, ECL4701 WH e ECL4702 WH pag. 24,
ECL4701 e ECL4702 pag. 34, ECL2701 pag. 100.

ECL4705 TEC pag. 14, ECL4705 WH pag. 24, ECL4705 pag. 34,
ECL4705 WHAB pag. 43,
ECL4701 TEC e ECL4702 TEC page 14, ECL4701 WH e ECL4702 WH page 24,
ECL4701 e ECL4702 page 34, ECL2701 pag. 100.

FUNZIONAMENTO

L'accensione o lo spegnimento del carico si effettua premendo il pomello di comando che agisce su un deviatore "push-push" incorporato nel variatore e coassiale al potenziometro di regolazione. La regolazione del carico controllato si effettua ruotando la manopola di comando del variatore stesso. La spia luminosa frontale del variatore assume la massima o la minima luminosità a seconda della regolazione impostata.

OPERATION

Device switching on and off is possible pushing the control knob, that operates on a 2 way single pole switch inside the light dimmer and coaxial with the control potentiometer. The electrical load adjustment is possible rotating the knob. The frontal pilot light reaches the max or min brightness according to the electrical load adjustment done.

<p>ECL 4705 Carichi comandabili: Lampade a led dimmerabili, carichi resistivi ed induttivi Compatible loads: Dimmerable led lamps, resistive and inductive</p>	
<p>ECL 4701 - ECL 2701 Carichi comandabili: Resistivi Lampade ad incandescenza o alogene a 220V~ Compatible loads: Resistive Incandescent or halogen lamps 220V~</p>	<p>ECL 4702 Carichi comandabili: Induttivi Trasformatori tradizionali per lampade alogene a bassissima tensione, Ventilatori, aspiratori, agitatori azionati da motori monofase a induzione. Compatible loads: Inductive Induction transformer for halogen lamp with low load (6-12-24V~). Fans, exhaust fans, mixers, motorized by an induction single phase motor.</p>
<p>Comando da un punto One point control</p>	<p>Comando per agitatori d'aria Fans control</p>
<p>Comando da due punti: variatore + deviatore Two point control: light dimmer + 2way single pole switch</p>	<p>Comando per aspiratori d'aria Extractor fans control</p>
<p>Comando da tre punti: variatore + invertitore + deviatore Three point control: light dimmer + intermediate switch + 2way single pole switch</p>	

VARIATORI DI LUMINOSITÀ ROTATIVI REVOLVING LIGHT DIMMERS

ECL4703 TEC e ECL4704 TEC pag. 14, ECL4703 WH e ECL4704 WH pag. 24, ECL4703 e ECL4704 pag. 34.

ECL4703 TEC e ECL4704 TEC page 14, ECL4703 WH e ECL4704 WH page 24, ECL4703 e ECL4704 page 34.

FUNZIONAMENTO

L'accensione, lo spegnimento e la regolazione del carico si effettuano ruotando il pomello di comando del variatore.

In base al verso della rotazione si aumenta o si diminuisce l'intensità del carico e della luminosità:

- in senso antiorario, la regolazione del carico viene portata al minimo livello e la spia frontale assume la massima luminosità.
- in senso orario, la regolazione del carico viene portata al massimo livello e la luminosità della spia frontale diminuisce gradualmente fino al suo azzeramento.

OPERATION

Device switching on/off and electric load adjustment are possible rotating the light dimmer control knob.

According to the roll direction, load intensity and brightness increase or decrease:

- counterclockwise, electric load arrives to the minimum and the frontal pilot light brightness increases.
- counterclockwise, electric load arrives to the maximum and the frontal pilot light brightness decreases.

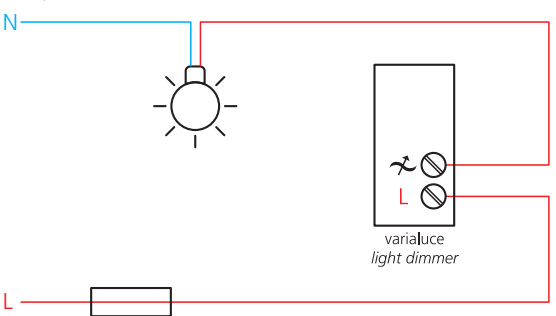
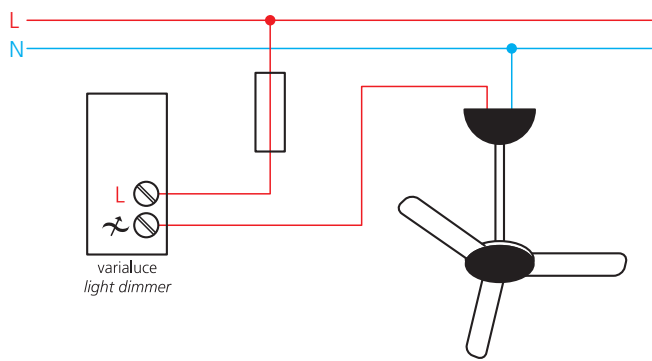
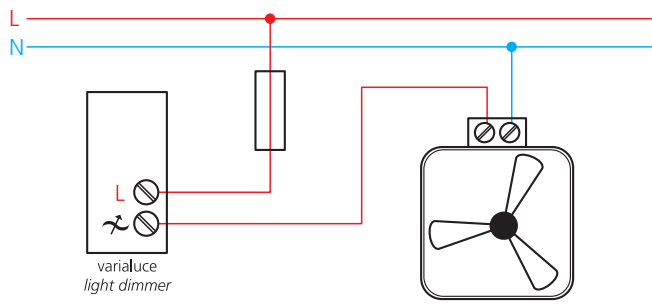
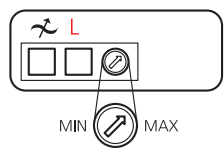
<p>ECL 4703</p> <p>Carichi comandabili: Resistivi Lampade ad incandescenza o alogene a 220V~</p> <p>Compatible loads: Resistive Incandescent or halogen lamps 220V~</p>	<p>ECL 4704</p> <p>Carichi comandabili: Induttivi Ventilatori, aspiratori, agitatori etc. azionati da motori monofase a induzione.</p> <p>Compatible loads: Inductive Fans, exhaust fans, mixers, motorised by an induction single phase motor.</p>
<p>Comando da un punto One point control</p> 	<p>Comando per agitatori d'aria Fans control</p> 
<p>Comando per aspiratori d'aria Extractor fans control</p> 	<p>Regolazione del minimo Minimum adjustment</p>  <p>Trimmer per la regolazione del minimo Trimmer for adjustment</p> <p>In alcuni modelli di agitatori d'aria, dopo circa 30 minuti di funzionamento al minimo, si può verificare un'alterazione del livello minimo impostato. È necessario, quindi, ripetere a caldo la taratura del minimo.</p> <p>In some type of extractor fans, after 30 min. of minimum operating, could appears an alliteration of minimum planned level. It have to repeat the minimum calibration</p>

SEGNALATORE OTTICO/ACUSTICO PER CHIAMATE DI EMERGENZA OPTICAL/ACOUSTIC INDICATOR DEVICE FOR EMERGENCY CALLS

ECL4076 pag. 15, 25, 35.

Il segnalatore ottico/acustico elettronico permette una segnalazione di emergenza che aziona l'allarme acustico di tipo intermittente e quello ottico fisso.

ECL4076 page 15, 25, 35.

Electronic optic/hearing device allows an emergency signal producing an intermittent sound and a red light.

SCHEMA DI COLLEGAMENTO

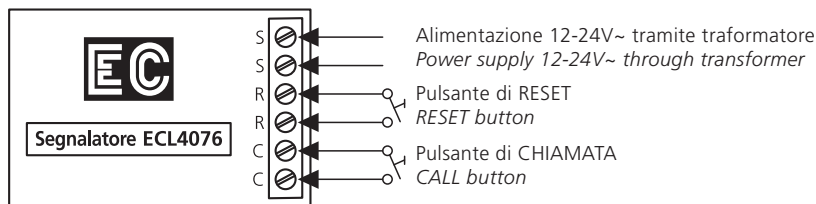

CONNECTION LAYOUT

FUNZIONAMENTO

La segnalazione di emergenza viene attivata mediante un pulsante di chiamata che aziona l'allarme acustico di tipo intermittente e quello ottico fisso. La segnalazione di emergenza viene disattivata mediante un pulsante di reset che disabilita il dispositivo.

OPERATION

Emergency signal puts into operation through a call button that sets off flashing hearing alarm and fixed optical alarm. Emergency signal stops through a reset button that disables the device.

È possibile configurare il dispositivo eliminando la segnalazione acustica attraverso la seguente procedura:

- Togliere l'alimentazione al dispositivo.
- Inserire un ponticello tra i morsetti "R R" ed un altro ponticello tra i morsetti "C C".
- Dare alimentazione al dispositivo il quale emetterà delle brevi segnalazioni acustiche/luminose a conferma dell'avvenuta programmazione.
- Togliere di nuovo l'alimentazione, togliere i ponticelli dai morsetti "C C" ed "R R".
- Attendere 10 secondi e dare nuovamente alimentazione al dispositivo.

It's possible to set the device removing the hearing alarm through the following procedure:

- Turn off device power supply.
- Put a wire between "R R" clamps, and another one between "C C" clamps.
- Give power supply to device that will produce short hearing/optic signals as confirmation of setting.
- Turn off device power supply, remove wires from "C C" ed "R R" clamps.
- Wait 10 seconds and give power supply to device.

In questa nuova configurazione, il segnalatore, all'attivazione di una chiamata emetterà una breve nota acustica della durata di due secondi dopodiché si taciterà facendo rimanere attiva solo la segnalazione luminosa fissa. Dopo circa venti secondi di attivazione, la segnalazione luminosa da fissa diventerà lampeggiante per aumentare il grado di attenzione alla chiamata di emergenza. Il dispositivo potrà comunque essere riprogrammato per l'attivazione della segnalazione acustica ripetendo la procedura sopra descritta.

When the device is set in this way, emergency signal will be characterized by a short sound, that will stop after 2 seconds, and fixed red light. After 20 seconds the red light starts flashing to increase the attention degree of emergency signal. The device could be set with the same procedure to rehabilitate hearing alarm.

CAMPO DI IMPIEGO:

Realizzazione di sistemi di chiamata in locali pubblici e/o privati (allarme bagno, allarme per azionamento maniglione antipanico) o nell'industria (officine, locali rumorosi, ecc.) con funzioni remote di segnalazione ottico/acustica per attivare richieste di assistenza, intervento, emergenza e/o segnalazioni di allarmi o avaria.

APPLICATION:

Realization of call systems in public or private places (bath-room alarm, alarm from anti-panic device) or industries (shop-floors, noisy environments). It gives remote signals optical-acoustical, to activate calls of assistance, intervention, emergency and/or signals of alarm or failure.

ESEMPI DI UTILIZZO:

- Segnalazioni di stato nei processi di lavorazione
- Segnalazioni di pericolo
- Segnalazioni di allarmi e/o avarie
- Segnalazioni per uscite di sicurezza
- Segnalazioni remote di chiamata e/o richiesta emergenza
- Segnalazioni remote per impianti antifurti

APPLICATION EXAMPLES:

- Step signal in manufacturing process
- Danger signal
- Alarm signal orland breakdown signal
- Signal for emergency exit
- Remote call signal orland emergency signal
- Remote signal for alarm system

ESEMPIO DI COLLEGAMENTO:

Realizzazione di un impianto per chiamata emergenza bagno.

CONNECTION EXAMPLE:

Installation of an emergency call system in toilet.

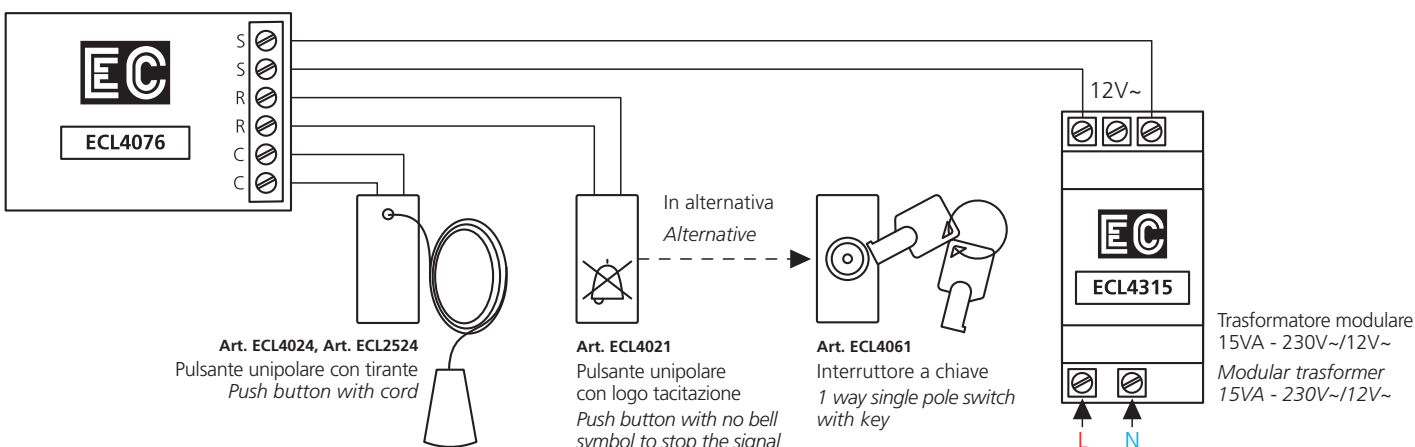

SEGNALATORE OTTICO/ACUSTICO - FUNZIONAMENTO AUTONOMO OPTICAL/ACOUSTIC INDICATOR DEVICE - INDEPENDENT OPERATION

ECL4077 pag. 15, 25, 35.

Il segnalatore ottico/acustico elettronico permette una segnalazione di emergenza tramite l'emissione di un suono intermittente e l'accensione di una spia luminosa rossa.

ECL4077 page 15, 25, 35.

Electronic optic/hearing device allows an emergency signal producing an intermittent sound and a red light.

SCHEMA DI COLLEGAMENTO

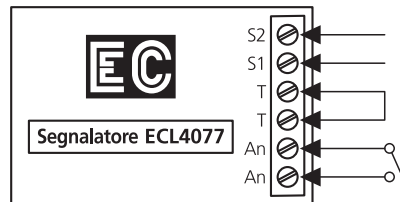

Alimentazione 12-24V~ tramite trasformatore
Power supply 12-24V~ through transformer

Tacitazione
Power off

Contatto di attivazione
Activation contact

CONNECTION LAYOUT

FUNZIONAMENTO

La segnalazione di emergenza viene attivata mediante la chiusura di contatto che aziona l'allarme acustico di tipo intermittente e quello ottico fisso.

Dopo circa 20 secondi l'allarme acustico viene disattivato mentre la segnalazione ottica rimane attiva divenendo intermittente.

La segnalazione di emergenza viene disattivata mediante l'apertura di contatto. È possibile configurare il dispositivo eliminando la segnalazione acustica attraverso la seguente procedura: inserire un ponticello tra i morsetti "T T".

In questa nuova configurazione, il segnalatore, all'attivazione di una chiamata emetterà una breve nota acustica della durata di due secondi dopodiché si taciterà facendo rimanere attiva solo la segnalazione luminosa fissa.

Dopo circa venti secondi di attivazione, la segnalazione luminosa da fissa diventerà lampeggiante per aumentare il grado di attenzione alla chiamata di emergenza. Il dispositivo potrà comunque essere riprogrammato per l'attivazione della segnalazione acustica togliendo il ponticello tra i morsetti "T T".

OPERATION

Emergency signal puts into operation through the contact closing that sets off flashing hearing alarm and fixed optical alarm.

After 20 seconds flashing hearing alarm stops and the red light starts flashing. Emergency signal stops through the open contact that disables the device.

It's possible to set the device removing the hearing alarm through the following procedure: put a wire between "T T" clamps.

When the device is set in this way, emergency signal will be characterized by a short sound, that will stops after 2 seconds, and fixed red light.

After 20 seconds the red light starts flashing to increase the attention degree of emergency signal.

The device could be set to rehabilitate hearing alarm removing the wire between "T T" clamps.

CAMPO DI IMPIEGO:

Realizzazione di sistemi di chiamata in locali di degenza (ospedali, case di riposo, cliniche) o nell'industria (officine, locali rumorosi, ecc.) con funzioni remote di segnalazione ottico/acustica per attivare richieste di assistenza, intervento, emergenza e/o segnalazioni di allarmi o avaria.

APPLICATION:

Realization of call systems in confinement places (hospitals, clinics) or industries (shop-floors, noisy environments).

It gives remote signals optical-acoustical, to activate calls of assistance, intervention, emergency and/or signals of alarm or failure.

ESEMPI DI UTILIZZO:

- Centraline controllo temperatura
- Centraline controllo livello liquidi
- Centraline rilevamento fumi
- Centraline rilevamento gas
- Segnalazioni di stato nei processi di lavorazione
- Segnalazioni di pericolo
- Segnalazioni di anomalie e/o avarie
- Segnalazioni per uscite di sicurezza
- Segnalazioni remote di chiamata e/o richiesta emergenza
- Segnalazioni remote per impianti antifurti
- Segnalazioni remote di chiamata per quadri luminosi

APPLICATION EXAMPLES:

- Control units for temperature
- Control units for liquid level
- Control units for gases
- Control units for exhaust smokes
- Step signal in manufacturing process
- Danger signal
- Alarm signal orland breakdown signal
- Signal for emergency exit
- Remote call signal orland emergency signal
- Remote signal for alarm system
- Remote call signal for light panel

ESEMPIO DI COLLEGAMENTO:

Realizzazione impianto di segnalazione apertura porte per uscite di emergenza.

CONNECTION EXAMPLE:

Installation of an emergency call system to opening emergency exit.

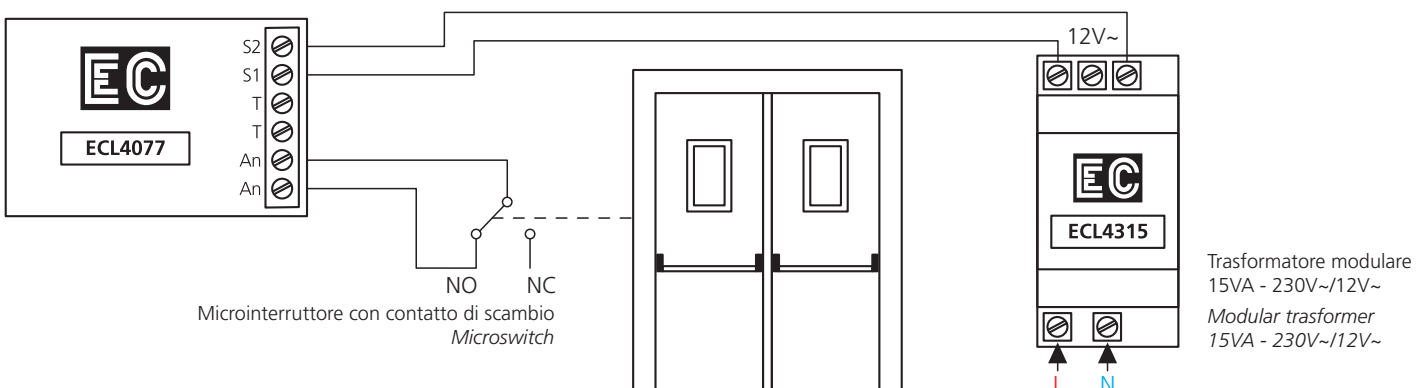

LAMPADA ESTRAIBILE DI EMERGENZA A LED 2 MODULI DA INCASSO 2 MODULES EXTRACTABLE LED EMERGENCY LAMP

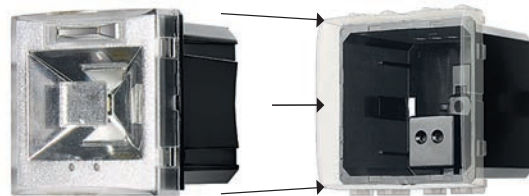

ECL40682E pag. 47 ECL40682E page 47

VISTA FRONTALE/Front VIEW

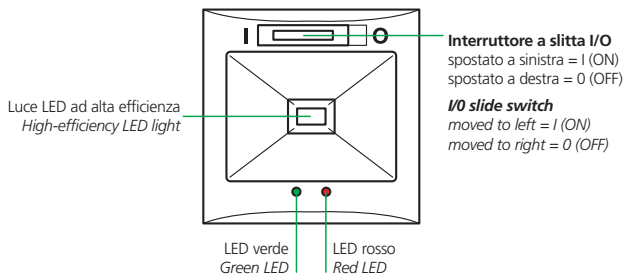

COLLEGAMENTO ELETRICO/ELECTRIC CONNECTION

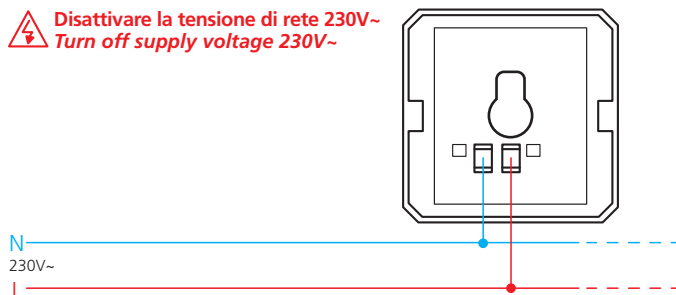

MODO DI FUNZIONAMENTO

- Interruttore a slitta in posizione **I** (dispositivo operativo) - LED verde **acceso**: batteria in fase di ricarica e in caso di interruzione della tensione di rete 230V~ (blackout) si attiva l'illuminazione di sicurezza.
- **In modalità torcia** l'interruttore in posizione **I** accende la lampada e in posizione **0** la spegne.
- La batteria interna sostituibile, garantisce più di due ore di autonomia di illuminazione.
- Per la prima ricarica della batteria sono necessarie circa 36 ore.
- Interruttore a slitta in posizione **0** (dispositivo inibito) - LED rosso **acceso**: batteria in fase di ricarica e in caso di interruzione della tensione di rete 230V~ (blackout) la lampada rimane spenta.

OPERATING MODE

- Slide switch in position **I** (device operating) - green LED **on**: battery charging and in case of blackout the safety lighting activates.
- **In torch mode** switch in position **I** switches the light on and in position **0** switches it off.
- The internal replaceable battery guarantees more than 2 hours of lighting autonomy.
- The battery needs approximately 36 hours to recharge the first time.
- Slide switch in position **0** (device inhibited) - red LED **on**: battery charging and in case of blackout the light remains off.

SOSTITUZIONE DELLA BATTERIA

BATTERY REPLACEMENT

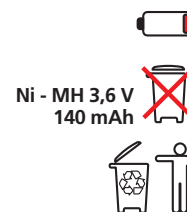
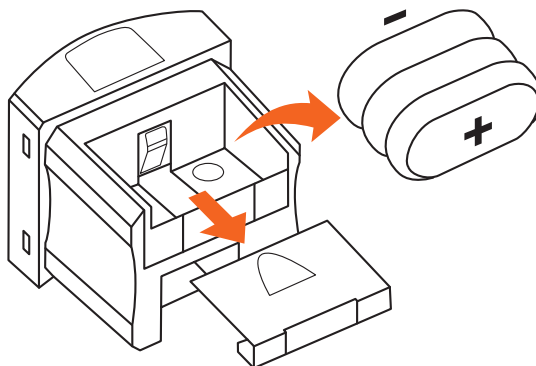
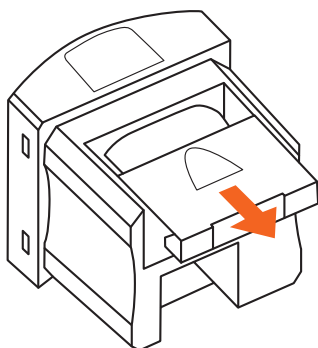

⚠ La batteria deve essere sostituita quando l'apparecchio non è più in grado di garantire una sufficiente luminosità e durata di accensione della lampada.

⚠ The battery must be replaced when the equipment is no longer able to guarantee sufficient brightness and switch-on duration of the light.

TOTEM ESPOSITIVI MYLIFE Q®, MYLIFE® E NEW PRESTIGE®
MYLIFE Q®, MYLIFE® AND NEW PRESTIGE® DISPLAYS



ESPOSITORI, CAMPIONARI ED IMBALLAGGI MYLIFE®
MYLIFE® DISPLAYS, SETS OF SAMPLES AND PACKAGING



ESPOSITORI, CAMPIONARI ED IMBALLAGGI MYLIFE Q®
MYLIFE Q® DISPLAYS, SETS OF SAMPLES AND PACKAGING



ESPOSITORI, CAMPIONARI ED IMBALLAGGI NEW PRESTIGE®
NEW PRESTIGE® DISPLAYS, SETS OF SAMPLES AND PACKAGING



ESPOSITORE LAMPADA DI EMERGENZA ECL6067
EMERGENCY LAMP ECL6067 DISPLAY



NOVITÀ NEW

ESPOSITORI, CAMPIONARI ED IMBALLAGGI EASY
EASY DISPLAYS, SETS OF SAMPLES AND PACKAGING



NOVITÀ NEW

Le foto dei prodotti riportate nel catalogo sono puramente indicative.
Elettrocanali si riserva la facoltà di apportare tutte le modifiche necessarie
allo scopo di migliorare le caratteristiche dei prodotti.

*Every product pictures, shown in this catalogue, are purely suggestive.
Elettrocanali could reserve the right to apply all the modifications to improve the products.*

Concept: © Propaganda Adv® - www.advpropaganda.com - Photo: © L. Innocente
Rev. 09-23 Photo archives: © CC Photo Service - Ingram - Photo Disc - Fotolia - Depositphotos